

Technical Support Center: Stabilizing Sudan IV-d6 in Solution

Author: BenchChem Technical Support Team. **Date:** May 2026

Compound of Interest

Compound Name: Sudan IV-d6

Cat. No.: B1368657

[Get Quote](#)

Product: **Sudan IV-d6** (Internal Standard) Application: LC-MS/MS Quantification of Azo Dyes
Issue Category: Photochemical Stability & Isomerization Document ID: TS-SUD4-ISO-001

The Mechanism: Why is my Internal Standard Changing?

The Core Physics: **Sudan IV-d6**, like its non-deuterated parent, contains an azo linkage () bridging two aromatic systems.[1] In its ground state, the molecule exists in the thermodynamically stable (E)-isomer (trans).

Upon exposure to photons—specifically in the UV and blue-visible spectrum—the electronic transition triggers a rotation around the azo bond, converting it to the (Z)-isomer (cis).

Why this destroys LC-MS accuracy:

- **Chromatographic Separation:** The cis-isomer has a different dipole moment and hydrodynamic volume than the trans-isomer. On a C18 column, the cis-isomer is more polar and typically elutes earlier than the trans-isomer.

- Peak Splitting: This results in "split peaks" or "fast peaks" (ghost peaks) in your chromatogram.[1]
- Quantification Error: Since **Sudan IV-d6** is your Internal Standard (IS), if the IS isomerizes at a different rate than your analyte (due to matrix effects or solvent differences), your area ratios will drift, invalidating the calibration.[1]

Isomerization Pathway Diagram

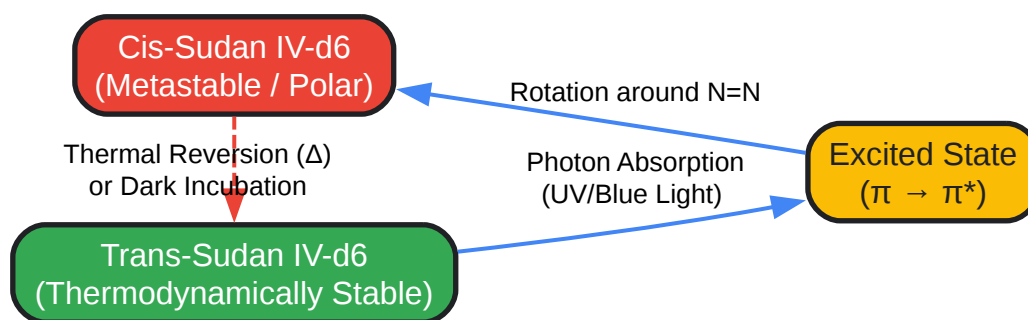

[Click to download full resolution via product page](#)

Figure 1: The reversible photo-isomerization cycle of **Sudan IV-d6**. Note that thermal energy (heat) drives the molecule back to the stable Trans state.

The "Dark Protocol": Storage & Handling

To ensure data integrity, you must treat **Sudan IV-d6** as a light-sensitive reagent at every step. [1] This protocol is designed to be self-validating: if followed, you will observe a single, sharp chromatographic peak.[1]

A. Stock Solution Preparation

Parameter	Recommendation	Scientific Rationale
Glassware	Amber Class A Volumetric	Amber glass blocks <450nm wavelengths, the primary driver of the and transitions.
Secondary Shielding	Aluminum Foil Wrap	Amber glass is not perfect.[1] Wrapping vials in foil provides 100% opacity.[1]
Solvent Choice	Non-Polar (e.g., Toluene, Hexane)	Azo dyes isomerize faster in polar solvents (like acetonitrile/water) due to stabilization of the polar transition state.[1] Keep stocks non-polar if possible.[1]
Temperature	-20°C (Dark)	Low temperature inhibits thermal degradation, while darkness prevents isomerization.[1]

B. Benchtop Handling (The Danger Zone)

Most isomerization occurs during the 15–30 minutes the sample sits on the bench during dilution.

- The "Red Light" Rule: If possible, perform dilutions in a room with UV-filtered lighting or low-intensity red LED lighting.[1]
- Foil-Wrapped Autosampler Vials: Do not trust the amber coating on standard 2mL autosampler vials. Wrap them in foil or use black-coated polymer vials.
- Speed: Minimize the time the solution is in a clear pipette tip.

Troubleshooting & FAQs

Q1: I see two peaks for **Sudan IV-d6** in my LC-MS trace. Is my standard degraded? A: Likely not degraded, but isomerized.

- Diagnosis: Check the mass spectrum of both peaks.^[2] If they have the identical precursor ion () and product ions but different retention times, they are isomers.
- The Fix (Thermal Reversion):
 - Wrap the sample vial in foil.
 - Incubate at 40–50°C for 30 minutes in the dark.
 - Re-inject immediately.^[1]
 - Result: The early-eluting "cis" peak should disappear or significantly diminish, merging back into the main "trans" peak.

Q2: Can I just sum the areas of the two peaks? A: Not recommended. The ionization efficiency (response factor) of the cis and trans forms in ESI source often differs due to their different dipole moments and solvation shells. Summing them introduces variable error depending on the cis/trans ratio. You must force the equilibrium to >99% trans for accurate quantification.

Q3: Does the column temperature affect this? A: Yes, significantly. Running your LC column at elevated temperatures (e.g., 40°C or 45°C) promotes on-column thermal reversion.^[1]

- Cold Column (20°C): Isomers separate distinctly.^[1]
- Hot Column (45°C): Rapid interconversion on the column often coalesces the peaks into a single, slightly broader band, which is preferable for integration.^[1]

Validated LC-MS Workflow

This workflow integrates the preventative measures into a logical process flow.

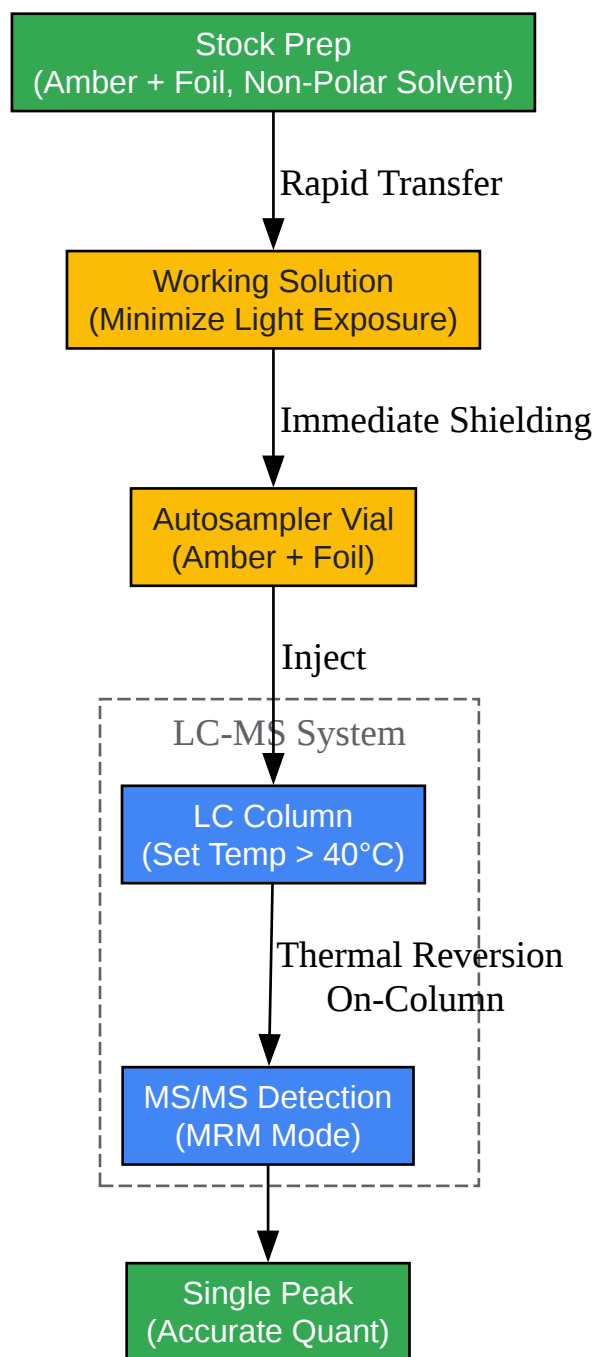

[Click to download full resolution via product page](#)

Figure 2: Optimized workflow for **Sudan IV-d6** analysis. Note the critical control point at the LC Column temperature.

Summary of Critical Parameters

Variable	Optimal Setting
Autosampler Tray	Dark / Covered (Peltier cooled to 4°C is fine, provided vials are dark)
Column Temperature	40°C – 50°C (Promotes cis trans reversion)
Mobile Phase	Acetonitrile/Water gradients are standard, but ensure standards are not left in this mix under light for long periods.
Detection	MRM (Multiple Reaction Monitoring). Verify transition ions match literature (typically fragment).

References

- European Commission. (2003).[1][3] Decision 2003/460/EC on emergency measures regarding chilli products and Sudan dyes.[1][3] Official Journal of the European Union. [Link](#)
- Mölder, et al. (2007).[1][4] Fast peaks in chromatograms of Sudan dyes.[1][4] Journal of Chromatography A. (Describes the cis-trans isomerization mechanism and peak splitting). [Link](#)
- Agilent Technologies. (2008).[1][3] A Rapid and Sensitive Analysis Method for Sudan Reds in Curry and Chili Powder Using LC/MS/MS.[1][3] (Application Note detailing LC-MS parameters). [Link](#)
- Waters Corporation. (2008).[1] A Rapid and Sensitive Analysis Method of Sudan Red I, II, III, and IV in Tomato Sauce Using UPLC-MS/MS. (Protocol for extraction and internal standard usage). [Link](#)
- BenchChem. (2025).[1][5] Technical Support Center: Optimizing Chromatographic Resolution of Sudan Dyes and Isomers. (Troubleshooting split peaks). [Link](#)

Need Custom Synthesis?

BenchChem offers custom synthesis for rare earth carbides and specific isotopic labeling.

Email: info@benchchem.com or [Request Quote Online](#).

Sources

- [1. pubs.acs.org](https://pubs.acs.org) [pubs.acs.org]
- [2. lcms.cz](https://lcms.cz) [lcms.cz]
- [3. agilent.com](https://agilent.com) [agilent.com]
- [4. Method development and survey of Sudan I–IV in palm oil and chilli spices in the Washington, DC, area - PMC](#) [[pmc.ncbi.nlm.nih.gov](https://pubmed.ncbi.nlm.nih.gov)]
- [5. benchchem.com](https://www.benchchem.com) [[benchchem.com](https://www.benchchem.com)]
- To cite this document: BenchChem. [Technical Support Center: Stabilizing Sudan IV-d6 in Solution]. BenchChem, [2026]. [Online PDF]. Available at: [<https://www.benchchem.com/product/b1368657/docs#technical-support-center-stabilizing-sudan-iv-d6-in-solution>]

Disclaimer & Data Validity:

The information provided in this document is for Research Use Only (RUO) and is strictly not intended for diagnostic or therapeutic procedures. While BenchChem strives to provide accurate protocols, we make no warranties, express or implied, regarding the fitness of this product for every specific experimental setup.

Technical Support: The protocols provided are for reference purposes. Unsure if this reagent suits your experiment?

Need Industrial/Bulk Grade? [Request Custom Synthesis Quote](#)

BenchChem

Our mission is to be the trusted global source of essential and advanced chemicals, empowering scientists and researchers to drive progress in science and industry.

Contact

Address: 3281 E Guasti Rd

Ontario, CA 91761, United States

Phone: (601) 213-4426

Email: info@benchchem.com

[Contact our Ph.D. Support Team for a compatibility check](#)