

Technical Support Center: A Troubleshooting Guide for Pyrazole Synthesis Impurities

Author: BenchChem Technical Support Team. **Date:** May 2026

Compound of Interest

Compound Name: (1,3-diphenyl-1H-pyrazol-5-yl)methanol
CAS No.: 16492-63-0
Cat. No.: B1368993

[Get Quote](#)

Welcome to the Technical Support Center. This guide is designed for researchers, scientists, and drug development professionals encountering common challenges in pyrazole synthesis. As a Senior Application Scientist, my goal is to provide you with not just protocols, but the underlying chemical principles to empower you to troubleshoot effectively. We will explore the nuances of the most prevalent pyrazole synthesis methods, focusing on the identification and mitigation of common impurities.

Frequently Asked Questions (FAQs)

Q1: My Knorr pyrazole synthesis with an unsymmetrical 1,3-dicarbonyl is producing a mixture of regioisomers. How can I improve the selectivity for my desired product?

This is a classic challenge in pyrazole synthesis.^{[1][2]} The reaction of an unsymmetrical 1,3-dicarbonyl compound with a substituted hydrazine can lead to two different regioisomeric

pyrazoles.[1] The outcome is governed by a delicate balance of steric and electronic factors, as well as reaction conditions.

Causality: The initial nucleophilic attack of the hydrazine can occur at either of the two carbonyl carbons. The subsequent cyclization and dehydration then lead to the respective pyrazole isomers. The inherent electronic differences between the two carbonyls and the steric hindrance around them dictate the preferred site of initial attack.

Troubleshooting Steps:

- **Solvent Optimization:** The choice of solvent can significantly influence regioselectivity.[1] Standard solvents like ethanol often lead to mixtures. Fluorinated alcohols, such as 2,2,2-trifluoroethanol (TFE) and 1,1,1,3,3,3-hexafluoro-2-propanol (HFIP), have been shown to dramatically increase regioselectivity in many cases.[1] These solvents can modulate the reactivity of the carbonyl groups through hydrogen bonding.
- **Temperature Control:** Reaction temperature is a critical parameter that can alter the reaction pathway.[1] It is advisable to run the reaction at a lower temperature initially and monitor the isomeric ratio by techniques like ¹H NMR or LC-MS.
- **Catalyst Choice:** While the Knorr synthesis is often acid-catalyzed, the choice of acid can impact the outcome.[3][4][5] Experimenting with different Brønsted or Lewis acids may be beneficial.
- **Alternative Synthetic Routes:** If optimization of the Knorr synthesis proves insufficient, consider alternative strategies:
 - **Using 1,3-Dicarbonyl Surrogates:** β-enaminones are excellent surrogates for 1,3-dicarbonyls and can provide superior regio-control.[1][2]
 - **1,3-Dipolar Cycloadditions:** This method involves the reaction of a diazo compound with an alkyne or alkene and can offer excellent regioselectivity.[1]
 - **Multicomponent Reactions:** One-pot, multicomponent syntheses, often catalyzed by Lewis acids, can provide regioselective access to highly substituted pyrazoles.[1]

Q2: I'm observing an unexpected byproduct in my pyrazole synthesis from a chalcone and hydrazine. What could it be?

Synthesizing pyrazoles from α,β -unsaturated ketones (chalcones) and hydrazines is a common and effective method.^{[6][7]} However, side reactions can occur, leading to impurities.

Common Byproducts and Their Formation:

- **Pyrazoline Intermediates:** The initial reaction between a chalcone and hydrazine often forms a pyrazoline, which is a partially reduced form of pyrazole.^[7] In some cases, this intermediate may not fully oxidize to the final pyrazole product, especially if the reaction conditions are not sufficiently vigorous or if an oxidizing agent is absent.
- **Schiff Base Hydrazones:** Under certain conditions, the reaction may stall after the initial condensation of the hydrazine with the carbonyl group of the chalcone, resulting in the formation of a stable Schiff base hydrazone.^[8]
- **Michael Addition Products:** It's possible for the hydrazine to undergo a Michael addition to the β -carbon of the chalcone without subsequent cyclization, leading to an open-chain adduct.

Troubleshooting and Identification:

- **Reaction Monitoring:** Closely monitor the reaction progress using Thin Layer Chromatography (TLC) or Liquid Chromatography-Mass Spectrometry (LC-MS).^{[6][9][10]} This will help you determine if the reaction has gone to completion.
- **Reaction Conditions:**
 - **Solvent and Catalyst:** The reaction is often carried out in an acidic medium, such as acetic acid, which facilitates both the initial condensation and the subsequent cyclization and dehydration.^{[6][8]}
 - **Temperature and Time:** Ensure the reaction is heated for a sufficient duration to drive the conversion of any intermediates to the final pyrazole product. Refluxing for several hours

is common.[6][8]

- Characterization: Utilize spectroscopic techniques to identify the impurity.
 - ¹H NMR: The presence of signals corresponding to CH-CH₂ protons in the pyrazoline ring or the absence of the characteristic aromatic pyrazole proton can indicate the presence of a pyrazoline intermediate.
 - Mass Spectrometry: The molecular weight of the impurity can help differentiate between a pyrazoline, a Schiff base, or the desired pyrazole.

Q3: My N-alkylation of a substituted pyrazole is giving a mixture of N1 and N2 isomers. How can I control the regioselectivity?

The N-alkylation of pyrazoles is a fundamental transformation, but controlling the site of alkylation on unsymmetrical pyrazoles can be challenging, often yielding a mixture of N1 and N2 alkylated products.[11]

Factors Influencing N1/N2 Regioselectivity:

- Steric Hindrance: Alkylation generally favors the less sterically hindered nitrogen atom.[11] Bulky substituents on the pyrazole ring or a bulky alkylating agent will direct the reaction towards the more accessible nitrogen.[11]
- Electronic Effects: The electronic nature of the substituents on the pyrazole ring influences the nucleophilicity of the adjacent nitrogen atoms.[11]
- Base and Solvent System: The choice of base and solvent is critical.[11]
 - Bases: Strong, non-nucleophilic bases like sodium hydride (NaH) can favor one isomer, while carbonate bases like K₂CO₃ or Cs₂CO₃ in polar aprotic solvents (DMF, DMSO) are often effective for regioselective N1-alkylation of 3-substituted pyrazoles.[11]
 - Solvents: Polar aprotic solvents often promote the formation of a single regioisomer.[11]
- Alternative Alkylation Methods:

- Acid-Catalyzed Alkylation: This method utilizes a Brønsted acid catalyst with trichloroacetimidates as electrophiles and can be a viable alternative to base-mediated methods.^{[11][12]}

In-Depth Troubleshooting Protocols

Protocol 1: Purification of Pyrazoles via Acid-Base Extraction

This protocol is particularly useful for removing non-basic impurities from your crude pyrazole product.

Principle: Pyrazoles are weakly basic due to the lone pair of electrons on the sp²-hybridized nitrogen atom. This allows for their selective protonation and extraction into an aqueous acidic phase, leaving non-basic impurities in the organic phase.

Step-by-Step Methodology:

- **Dissolution:** Dissolve the crude reaction mixture in a suitable organic solvent such as ethyl acetate or dichloromethane.
- **Acidic Extraction:** Transfer the organic solution to a separatory funnel and extract with a 1M aqueous solution of a mineral acid like hydrochloric acid (HCl). Repeat the extraction 2-3 times. The pyrazole will be protonated and move into the aqueous layer.
- **Separation:** Combine the aqueous extracts. The organic layer containing non-basic impurities can be discarded.
- **Basification:** Cool the combined aqueous extracts in an ice bath and slowly add a base, such as a saturated sodium bicarbonate solution or 1M sodium hydroxide, until the solution is basic (check with pH paper). The protonated pyrazole will be neutralized and precipitate out of the solution.
- **Isolation:** Collect the precipitated solid by filtration, wash with cold water, and dry under vacuum.

Protocol 2: Recrystallization for Isomer Separation

For cases where a mixture of regioisomers is obtained, recrystallization can sometimes be an effective purification method, provided the isomers have sufficiently different solubilities in a particular solvent system.

Step-by-Step Methodology:

- **Solvent Screening:** In small test tubes, test the solubility of your crude product in various solvents (e.g., ethanol, methanol, ethyl acetate, hexane, and mixtures thereof) at room temperature and upon heating. An ideal recrystallization solvent will dissolve the compound when hot but not when cold.
- **Dissolution:** In a flask, dissolve the crude product in the minimum amount of the chosen hot solvent.
- **Hot Filtration (if necessary):** If there are any insoluble impurities, perform a hot filtration to remove them.
- **Crystallization:** Allow the solution to cool slowly to room temperature. If crystals do not form, you can try scratching the inside of the flask with a glass rod or adding a seed crystal. Further cooling in an ice bath can also promote crystallization.
- **Isolation and Analysis:** Collect the crystals by filtration, wash with a small amount of the cold solvent, and dry. Analyze the purity of the crystals and the mother liquor by TLC or ^1H NMR to determine if a successful separation has been achieved. It may be necessary to perform multiple recrystallizations to obtain a pure isomer.

Data Presentation

Table 1: Solvent Effects on Regioselectivity in Knorr Pyrazole Synthesis

Solvent	Dielectric Constant (ϵ)	Typical Regioisomeric Ratio (A:B)	Reference
Ethanol	24.55	1:1 to 3:1	
2,2,2-Trifluoroethanol (TFE)	26.7	>10:1	
1,1,1,3,3,3-Hexafluoro-2-propanol (HFIP)	16.7	>20:1	[1]

Note: Ratios are illustrative and can vary depending on the specific substrates used.

Visualizing Impurity Formation

Diagram 1: Knorr Pyrazole Synthesis and Regioisomer Formation

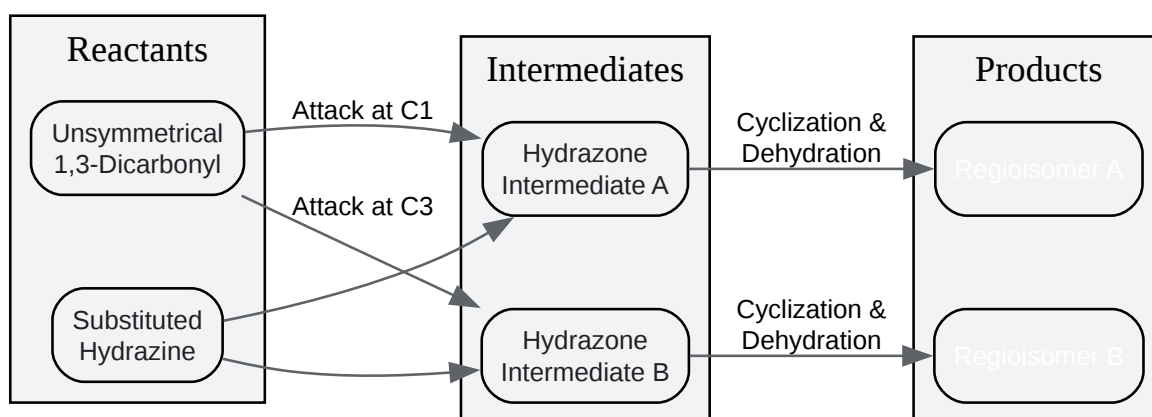

[Click to download full resolution via product page](#)

Caption: Knorr synthesis pathways leading to regioisomers.

Diagram 2: Troubleshooting Workflow for Pyrazole Purification

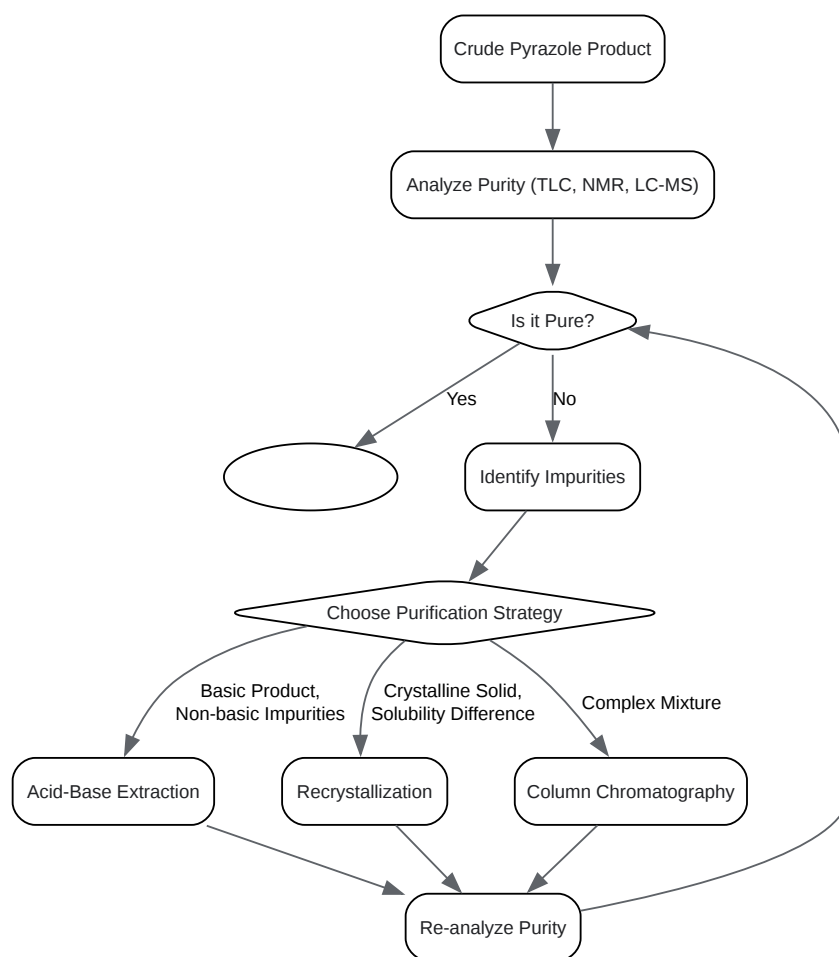

[Click to download full resolution via product page](#)

Caption: A logical workflow for pyrazole purification.

References

- A Concise Review on the Synthesis of Pyrazole Heterocycles. Hilaris Publisher. (2015). [\[Link\]](#)
- Comparison of various synthesis methods and synthesis parameters of pyrazoline derivatives. (2022). AIP Conference Proceedings. [\[Link\]](#)
- Knorr pyrazole synthesis. Name-Reaction.com. (n.d.). [\[Link\]](#)
- Synthesis, Reactions and Medicinal Uses of Pyrazole. Pharmaguideline. (n.d.). [\[Link\]](#)
- Recent Advances in the Synthesis of Pyrazole Derivatives: A Review. MDPI. (2023). [\[Link\]](#)

- SYNTHESIS AND EVALUATION OF PYRAZOLE DERIVATIVES BY USING GREEN CATALYST. Jetir.Org. (n.d.). [\[Link\]](#)
- Knorr Pyrazole Synthesis. Chem Help Asap. (n.d.). [\[Link\]](#)
- Improved Regioselectivity in Pyrazole Formation through the Use of Fluorinated Alcohols as Solvents: Synthesis and Biological Activity of Fluorinated Tebufenpyrad Analogs. (2006). Organic Process Research & Development. [\[Link\]](#)
- Process for the purification of pyrazoles.
- Synthesis and Crystal Structures of N-Substituted Pyrazolines. (2012). International Journal of Molecular Sciences. [\[Link\]](#)
- Design And Development of Pyrazole-Substituted Chalcones: A Synthetic Perspective. IJIRT Journal. (n.d.). [\[Link\]](#)
- Method for purifying pyrazoles.
- Knorr Pyrazole Synthesis. J&K Scientific LLC. (2025). [\[Link\]](#)
- Knorr Pyrazole Synthesis (M. Pharm). Slideshare. (n.d.). [\[Link\]](#)
- Synthesis of Pyrazoline Derivatives from Chalcones. (2017). Capstone, The UNC Asheville Journal of Undergraduate Scholarship. [\[Link\]](#)
- Synthesis and Pharmacological Activities of Pyrazole Derivatives: A Review. (2019). Molecules. [\[Link\]](#)
- Iodine-promoted synthesis of pyrazoles from 1,3-dicarbonyl compounds and oxamic acid thiohydrazides. (2018). Organic Chemistry Frontiers. [\[Link\]](#)
- Synthesis and antimicrobial activity of new pyrazolone and pyrazole-based adamantyl chalcones. (2020). Bioscience Reports. [\[Link\]](#)
- Synthesis of pyrazolines by reaction of chalcone with hydrazine in ethanol. ResearchGate. (n.d.). [\[Link\]](#)

- Pyrazole chemistry has developed rapidly since the publication of the last review. (n.d.). Science of Synthesis. [\[Link\]](#)
- How can I purify a pyrazole compound with a N-C-N bond without using a silica column? ResearchGate. (2014). [\[Link\]](#)
- 194 recent advances in the synthesis of new pyrazole derivatives. (n.d.). Revista de la Sociedad Química de México. [\[Link\]](#)
- Regioselective Synthesis of 5- and 3-Hydroxy-N-Aryl-1H-Pyrazole-4-Carboxylates and Their Evaluation as Inhibitors of Plasmodium falciparum Dihydroorotate Dehydrogenase. (2019). Molecules. [\[Link\]](#)
- Recent Advances in Synthesis and Properties of Pyrazoles. MDPI. (2022). [\[Link\]](#)
- Highly Selective N-Alkylation of Pyrazoles: Crystal Structure Evidence for Attractive Interactions. (2018). The Journal of Organic Chemistry. [\[Link\]](#)
- Synthesis and biological profiling of novel pyrazoles as antioxidant, antibacterial, and antimetabolic agents: An in vitro and in silico approach. (2025). Arabian Journal of Chemistry. [\[Link\]](#)
- Exploring the Synthetic Strategies and Biological Activities of Pyrazole Derivatives. (2024). PDF. [\[Link\]](#)
- Acid Catalyzed N-Alkylation of Pyrazoles with Trichloroacetimidates. MDPI. (2022). [\[Link\]](#)
- Synthesis, Characterization of Pyrano-[2,3-c]-Pyrazoles Derivatives and Determination of Their Antioxidant Activities. (2021). Iranian Journal of Toxicology. [\[Link\]](#)
- SYNTHESIS, CHARACTERIZATION AND BIOLOGICAL EVALUATION OF SUBSTITUTED PYRAZOLINE DERIVATIVES. Paper Publications. (n.d.). [\[Link\]](#)
- Multicomponent syntheses of pyrazoles via (3 + 2)-cyclocondensation and (3 + 2)-cycloaddition key steps. (2017). Beilstein Journal of Organic Chemistry. [\[Link\]](#)

- A Highly Validated RP-HPLC Method for Pyrazoline Derivative Having Anti-inflammatory Activity. (2014). International Journal of ChemTech Applications. [[Link](#)]
- Synthesis and Evaluation of Pyrazole Derivatives by Different Method. (2025). International Journal of Pharmaceutical Research and Applications. [[Link](#)]
- Direct Preparation of N-Substituted Pyrazoles from Primary Aliphatic or Aromatic Amines. (2021). The Journal of Organic Chemistry. [[Link](#)]
- Process for the preparation of pyrazole and its derivatives.
- Activation Energy Estimation for Alkylation of Pyrazole (Part II). WuXi Biology. (n.d.). [[Link](#)]
- N-alkylation method of pyrazole.
- Synthesis, Characterization and Pharmacological Evaluation of Pyrazole Derivatives Potent CNS Agents. (2025). Indian Journal of Chemistry. [[Link](#)]
- Pyrazole synthesis. Organic Chemistry Portal. (n.d.). [[Link](#)]

Need Custom Synthesis?

BenchChem offers custom synthesis for rare earth carbides and specific isotopic labeling.

Email: info@benchchem.com or [Request Quote Online](#).

Sources

- [1. pdf.benchchem.com](https://pdf.benchchem.com) [pdf.benchchem.com]
- [2. Recent Advances in the Synthesis of Pyrazole Derivatives: A Review](https://www.mdpi.com) [[mdpi.com](https://www.mdpi.com)]
- [3. name-reaction.com](https://www.name-reaction.com) [[name-reaction.com](https://www.name-reaction.com)]
- [4. jk-sci.com](https://www.jk-sci.com) [[jk-sci.com](https://www.jk-sci.com)]
- [5. Knorr Pyrazole Synthesis \(M. Pharm\) | PPTX](https://www.slideshare.net) [[slideshare.net](https://www.slideshare.net)]
- [6. ijirt.org](https://www.ijirt.org) [[ijirt.org](https://www.ijirt.org)]
- [7. portlandpress.com](https://www.portlandpress.com) [[portlandpress.com](https://www.portlandpress.com)]

- 8. Synthesis and Crystal Structures of N-Substituted Pyrazolines - PMC [pmc.ncbi.nlm.nih.gov]
- 9. Synthesis and biological profiling of novel pyrazoles as antioxidant, antibacterial, and antimetabolic agents: An *in vitro* and *in silico* approach - Arabian Journal of Chemistry [arabjchem.org]
- 10. paperpublications.org [paperpublications.org]
- 11. pdf.benchchem.com [pdf.benchchem.com]
- 12. mdpi.com [mdpi.com]
- To cite this document: BenchChem. [Technical Support Center: A Troubleshooting Guide for Pyrazole Synthesis Impurities]. BenchChem, [2026]. [Online PDF]. Available at: [<https://www.benchchem.com/product/b1368993/docs#technical-support-center-a-troubleshooting-guide-for-pyrazole-synthesis-impurities>]

Disclaimer & Data Validity:

The information provided in this document is for Research Use Only (RUO) and is strictly not intended for diagnostic or therapeutic procedures. While BenchChem strives to provide accurate protocols, we make no warranties, express or implied, regarding the fitness of this product for every specific experimental setup.

Technical Support: The protocols provided are for reference purposes. Unsure if this reagent suits your experiment?

Need Industrial/Bulk Grade? [Request Custom Synthesis Quote](#)

BenchChem

Our mission is to be the trusted global source of essential and advanced chemicals, empowering scientists and researchers to drive progress in science and industry.

Contact

Address: 3281 E Guasti Rd
Ontario, CA 91761, United States
Phone: (601) 213-4426
Email: info@benchchem.com

Contact our Ph.D. Support Team for a compatibility check