

An In-depth Technical Guide to N-(4-Ethynylphenyl)cyclohexanecarboxamide

Author: BenchChem Technical Support Team. **Date:** April 2026

Compound of Interest

Compound Name:	N-(4-Ethynylphenyl)cyclohexanecarboxamide
CAS No.:	118984-62-6
Cat. No.:	B1368369

[Get Quote](#)

Introduction: A Molecule of Latent Potential

N-(4-Ethynylphenyl)cyclohexanecarboxamide is a fascinating synthetic molecule that, despite its straightforward structure, does not currently possess a dedicated CAS number in major chemical databases. This suggests that while its constituent parts are well-known and its synthesis is chemically feasible, it remains a relatively unexplored compound. This guide aims to provide a comprehensive technical overview for researchers, scientists, and drug development professionals interested in this molecule. We will delve into its structure, a proposed synthetic route, predicted physicochemical properties, and, most importantly, its potential applications, which are largely predicated on the versatile reactivity of its terminal alkyne moiety. The information presented herein is synthesized from established chemical principles and data from structurally analogous compounds.

The core structure of **N-(4-Ethynylphenyl)cyclohexanecarboxamide** features a cyclohexanecarboxamide group appended to a 4-ethynylphenyl ring. The cyclohexyl group provides a non-planar, lipophilic character, while the amide linkage is a common and stable

functional group in many biologically active molecules.[1][2] The true synthetic and functional potential of this molecule, however, lies in the 4-ethynylphenyl group. The terminal alkyne is a highly versatile functional group, most notably for its utility in copper(I)-catalyzed azide-alkyne cycloaddition (CuAAC), a cornerstone of "click chemistry." This reaction allows for the efficient and specific formation of a stable triazole linkage, a valuable tool in drug discovery, bioconjugation, and materials science.

Chemical Structure and Properties

The chemical structure of **N-(4-Ethynylphenyl)cyclohexanecarboxamide** combines a rigid aromatic core with a flexible aliphatic ring, linked by a stable amide bond.

Structure:

- Cyclohexyl Group: A saturated six-membered ring providing bulk and lipophilicity.
- Amide Linkage: A planar and rigid group capable of hydrogen bonding.
- Phenyl Ring: An aromatic spacer.
- Ethynyl Group: A terminal alkyne that serves as a reactive handle for further functionalization.

Predicted Physicochemical Properties

While experimental data for **N-(4-Ethynylphenyl)cyclohexanecarboxamide** is not readily available, we can predict its key physicochemical properties based on structurally related compounds such as N-phenylcyclohexanecarboxamide (CAS: 2719-26-8) and N-(4-methylphenyl)cyclohexanecarboxamide (CAS: 6876-59-1).[3][4]

Property	Predicted Value	Rationale/Comparison
Molecular Formula	C ₁₅ H ₁₇ NO	Based on the constituent fragments.
Molecular Weight	~227.30 g/mol	Calculated from the molecular formula.
Appearance	White to off-white solid	Typical for similar crystalline organic amides.
Melting Point	150-170 °C	Expected to be in a similar range to N-(4-methylphenyl)cyclohexanecarboxamide.
Solubility	Soluble in polar organic solvents (e.g., DMSO, DMF, acetone), sparingly soluble in water.	The amide and aromatic portions confer some polarity, while the cyclohexyl and phenyl groups increase lipophilicity.
LogP	~3.5 - 4.0	The presence of the lipophilic cyclohexyl and phenyl groups suggests a moderate to high octanol-water partition coefficient.

Proposed Synthesis Workflow

The synthesis of **N-(4-Ethynylphenyl)cyclohexanecarboxamide** can be readily achieved through a standard nucleophilic acyl substitution reaction. This well-established method involves the reaction of an amine with an acyl chloride in the presence of a non-nucleophilic base to neutralize the HCl byproduct.^[5]

Experimental Protocol

Reaction: 4-Ethynylaniline + Cyclohexanecarbonyl chloride → **N-(4-Ethynylphenyl)cyclohexanecarboxamide**

Materials:

- 4-Ethynylaniline
- Cyclohexanecarbonyl chloride
- Triethylamine (or another suitable base like pyridine)
- Anhydrous dichloromethane (DCM) or tetrahydrofuran (THF)
- Saturated sodium bicarbonate solution
- Brine
- Anhydrous magnesium sulfate or sodium sulfate
- Standard laboratory glassware and purification apparatus (e.g., column chromatography)

Step-by-Step Procedure:

- **Reactant Preparation:** In a flame-dried round-bottom flask under an inert atmosphere (e.g., nitrogen or argon), dissolve 4-ethynylaniline (1.0 equivalent) and triethylamine (1.2 equivalents) in anhydrous DCM.
- **Addition of Acyl Chloride:** Cool the solution to 0 °C in an ice bath. To this stirred solution, add cyclohexanecarbonyl chloride (1.05 equivalents) dropwise via a syringe.
- **Reaction:** Allow the reaction mixture to warm to room temperature and stir for 4-12 hours. Monitor the reaction progress by thin-layer chromatography (TLC).
- **Work-up:** Upon completion, quench the reaction by adding water. Transfer the mixture to a separatory funnel and wash sequentially with saturated sodium bicarbonate solution and brine.
- **Drying and Concentration:** Dry the organic layer over anhydrous magnesium sulfate, filter, and concentrate under reduced pressure to obtain the crude product.

- Purification: Purify the crude product by flash column chromatography on silica gel using a suitable eluent system (e.g., a gradient of ethyl acetate in hexanes) to yield pure **N-(4-Ethynylphenyl)cyclohexanecarboxamide**.

Synthesis Workflow Diagram

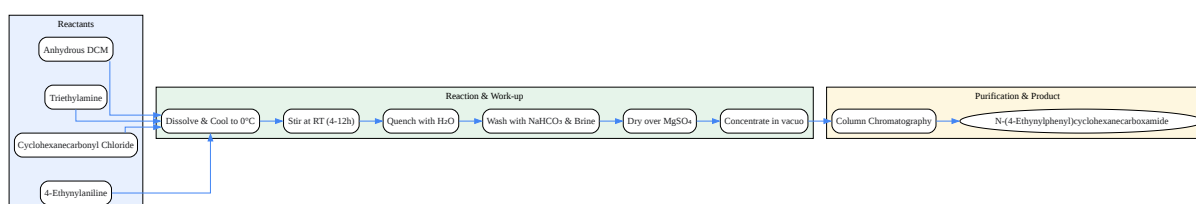

[Click to download full resolution via product page](#)

Caption: Proposed synthesis workflow for **N-(4-Ethynylphenyl)cyclohexanecarboxamide**.

Potential Applications in Research and Development

The primary utility of **N-(4-Ethynylphenyl)cyclohexanecarboxamide** stems from its terminal alkyne, which can participate in a variety of chemical transformations.

Click Chemistry and Bioconjugation

The ethynyl group is a key functional group for copper(I)-catalyzed azide-alkyne cycloaddition (CuAAC), a highly efficient and specific "click" reaction. This allows for the covalent attachment of **N-(4-Ethynylphenyl)cyclohexanecarboxamide** to molecules containing an azide group, such as proteins, nucleic acids, or surfaces. This could be utilized for:

- Labeling and Imaging: Attaching a fluorescent azide dye to the molecule for biological imaging applications.
- Drug Targeting: Conjugating the molecule to a targeting ligand (e.g., an antibody or peptide) to deliver a potential therapeutic payload.

Materials Science

The alkyne functionality can also be exploited in materials science for the synthesis of novel polymers and functional materials. For example, it could be used in:

- Polymer Synthesis: As a monomer in polymerization reactions, such as polycyclotrimerization, to create cross-linked polymers with high thermal stability.
- Surface Modification: Grafting the molecule onto surfaces to alter their properties, such as hydrophobicity or biocompatibility.

Medicinal Chemistry and Drug Discovery

The **N-(4-Ethynylphenyl)cyclohexanecarboxamide** scaffold itself may possess inherent biological activity. The combination of a lipophilic cyclohexyl ring and an aromatic amide is a common feature in many bioactive compounds. The ethynyl group can also interact with biological targets or serve as a precursor for further chemical modifications to explore structure-activity relationships (SAR). The amide functional group is a cornerstone of many pharmaceuticals, contributing to their stability and ability to form hydrogen bonds with biological targets.^[1]

Illustrative Click Reaction Pathway

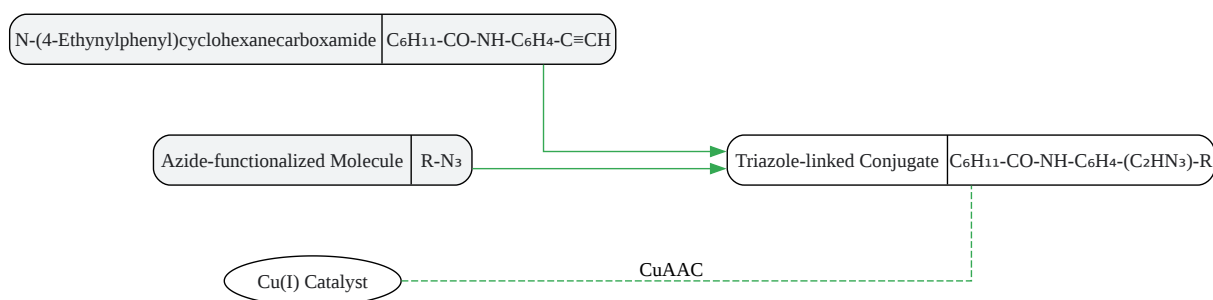

[Click to download full resolution via product page](#)

Caption: A potential CuAAC "click" reaction of the title compound.

Conclusion

N-(4-Ethynylphenyl)cyclohexanecarboxamide represents a molecule with significant untapped potential. While not yet widely cataloged, its synthesis is straightforward based on established organic chemistry principles. Its true value lies in the versatility of its 4-ethynylphenyl moiety, which opens up a vast landscape of possibilities in click chemistry, materials science, and drug discovery. This technical guide provides a foundational framework for researchers to begin exploring the synthesis and applications of this promising compound. Further experimental validation of its properties and reactivity will undoubtedly pave the way for its use in a wide range of scientific endeavors.

References

- Umpolung Amide Synthesis (UmAS) emerged from α -halo nitroalkane reactions with amines and has since been developed into a method for the synthesis of enantiopure amides using entirely catalytic, enantioselective synthesis. ([Link](#))
- We describe an efficient method for the direct preparation of N-substituted aryl amidines from nitriles and primary amines. ([Link](#))

- Umpolung amide synthesis (UmAS) emerged from α -halo nitroalkane reactions with amines and has since been developed into a method for the synthesis of enantiopure amides using entirely catalytic, enantioselective synthesis. ([Link](#))
- Amidines are a class of pharmaceutically relevant small molecules, in addition to being important building blocks for organic chemical synthesis and having a number of applications in materials chemistry. ([Link](#))
- N-Phenylcyclohexanecarboxamide | C₁₃H₁₇NO | CID 257030 - PubChem. ([Link](#))
- Method for preparing N-aryl amide without solvent and catalyst - Google P
- N-(4-ethynylphenyl)propanamide | C₁₁H₁₁NO | CID 11499296 - PubChem. ([Link](#))
- Cyclohexanecarboxamide, N-methyl-N-phenyl- | C₁₄H₁₉NO | CID 11053109 - PubChem. ([Link](#))
- Cyclohexanecarboxamide, N-(4-methylphenyl)- | C₁₄H₁₉NO | CID 95228 - PubChem. ([Link](#))
- Cyclohexanecarboxamide, N-phenyl-N-(1-(2-phenylethyl)-4-piperidiny)- | C₂₆H₃₄N₂O | CID - PubChem. ([Link](#))
- Amides are a significant class of organic compounds widely recognized for their unique structural and chemical properties. ([Link](#))
- The Amide Functional Group: Properties, Synthesis, and Nomenclature. ([Link](#))
- Synthesis of Functionalized N-(4-Bromophenyl)furan-2-carboxamides via Suzuki-Miyaura Cross-Coupling: Anti-Bacterial Activities against Clinically Isolated Drug Resistant A. baumannii, K. pneumoniae, E. cloacae and MRSA and Its Validation via a Computational Approach - MDPI. ([Link](#))
- Synthesis and Properties of New Functionalized Poly(imides) Based on 1,1-Bis(4-aminophenyl)-1-{4'-bis(4''-bromophenyl)amino}phenyl-2,2,2-trifluoroethane - ResearchGate. ([Link](#))

- Novel 4-Methylumbelliferone Amide Derivatives: Synthesis, Characterization and Pesticidal Activities - PubMed. ([\[Link\]](#))

Need Custom Synthesis?

BenchChem offers custom synthesis for rare earth carbides and specific isotopic labeling.

Email: info@benchchem.com or [Request Quote Online](#).

Sources

- 1. What Are Amides? Understanding Their Structure, Properties, and Applications [qixuanchemtec.com]
- 2. masterorganicchemistry.com [masterorganicchemistry.com]
- 3. N-Phenylcyclohexanecarboxamide | C₁₃H₁₇NO | CID 257030 - PubChem [pubchem.ncbi.nlm.nih.gov]
- 4. Cyclohexanecarboxamide, N-(4-methylphenyl)- | C₁₄H₁₉NO | CID 95228 - PubChem [pubchem.ncbi.nlm.nih.gov]
- 5. mdpi.com [mdpi.com]
- To cite this document: BenchChem. [An In-depth Technical Guide to N-(4-Ethynylphenyl)cyclohexanecarboxamide]. BenchChem, [2026]. [Online PDF]. Available at: [<https://www.benchchem.com/product/b1368369/docs#an-in-depth-technical-guide-to-n-4-ethynylphenyl-cyclohexanecarboxamide>]

Disclaimer & Data Validity:

The information provided in this document is for Research Use Only (RUO) and is strictly not intended for diagnostic or therapeutic procedures. While BenchChem strives to provide accurate protocols, we make no warranties, express or implied, regarding the fitness of this product for every specific experimental setup.

Technical Support: The protocols provided are for reference purposes. Unsure if this reagent suits your experiment?

Need Industrial/Bulk Grade? [Request Custom Synthesis Quote](#)

BenchChem

Our mission is to be the trusted global source of essential and advanced chemicals, empowering scientists and researchers to drive progress in science and industry.

Contact

Address: 3281 E Guasti Rd

Ontario, CA 91761, United States

Phone: (601) 213-4426

Email: info@benchchem.com

[Contact our Ph.D. Support Team for a compatibility check](#)