

Assessing the Selectivity of 5-Methoxynicotinohydrazide-Based Compounds: A Comparative Guide

Author: BenchChem Technical Support Team. **Date:** April 2026

Compound of Interest

Compound Name: 5-Methoxynicotinohydrazide

Cat. No.: B13677600

[Get Quote](#)

Executive Summary

In the landscape of antimycobacterial drug discovery, the nicotinohydrazide scaffold represents a critical pivot from the traditional isonicotinic acid hydrazide (Isoniazid/INH) class. While INH remains a frontline tuberculosis (TB) therapy, its utility is compromised by widespread resistance (primarily katG mutations) and hepatotoxicity.

5-Methoxynicotinohydrazide (5-MNH) derivatives are emerging as a strategic alternative. By shifting the hydrazide moiety from the C4 (isonicotinic) to the C3 (nicotinic) position and introducing an electron-donating methoxy group at C5, researchers aim to:

- Bypass katG activation dependence, potentially overcoming MDR-TB resistance.
- Mitigate hepatotoxicity associated with hydrazine metabolite accumulation.
- Avoid CNS off-target effects, specifically the inhibition of Monoamine Oxidase (MAO), a liability historically seen with nicotinic acid hydrazide derivatives like Iproniazid.

This guide outlines the experimental framework to rigorously assess the selectivity of 5-MNH compounds against these critical biological benchmarks.

Part 1: Structural Basis & Target Engagement

The Isomeric Shift

The distinction between Isoniazid and 5-MNH is structural but has profound pharmacological implications.

- Isoniazid (INH): Pyridine-4-hydrazide. Requires oxidative activation by the bacterial catalase-peroxidase KatG to form the isonicotinic acyl radical, which binds NADH and inhibits InhA (enoyl-ACP reductase).
- **5-Methoxynicotinohydrazide (5-MNH):** Pyridine-3-hydrazide with a C5-methoxy substituent. The C3 position alters the electronics of the pyridine ring, potentially changing the activation pathway or allowing direct binding to InhA, while the C5-methoxy group modulates lipophilicity (LogP) and metabolic stability.

Mechanistic Diagram

The following diagram illustrates the divergent pathways of activation and target engagement between the standard (INH) and the alternative (5-MNH).

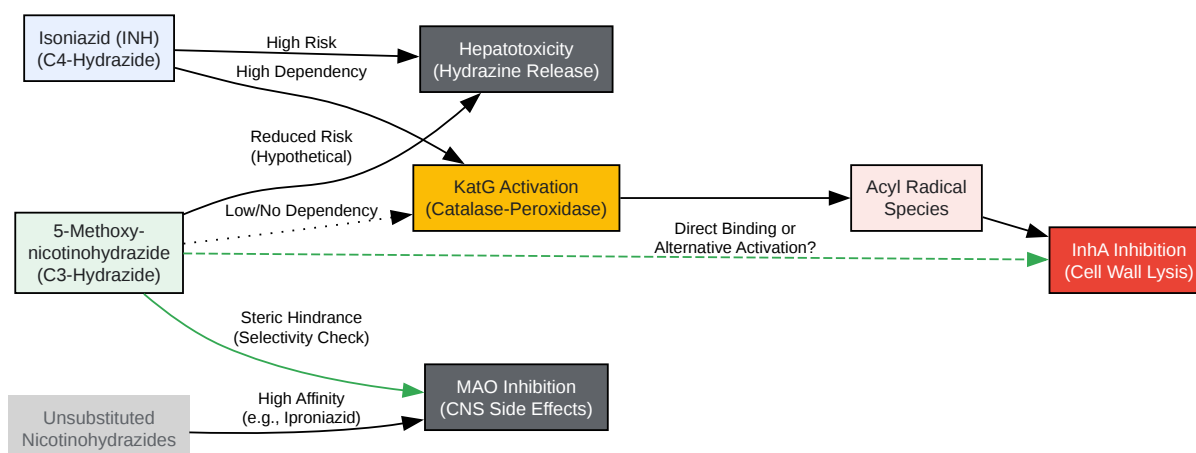

[Click to download full resolution via product page](#)

Caption: Comparative mechanism of action. 5-MNH aims to retain InhA inhibition while bypassing KatG dependency and avoiding MAO off-target binding common in early nicotinohydrazides.

Part 2: Comparative Performance Guide

When evaluating 5-MNH derivatives, data must be benchmarked against standard-of-care and historical failures to prove superiority.

Comparator Compound	Role in Assay	Primary Liability/Weakness	5-MNH Target Profile
Isoniazid (INH)	Positive Control (Potency)	Resistance (MDR-TB); Hepatotoxicity.	Equal Potency (MIC < 0.5 µg/mL) with activity against katG mutants.
Iproniazid	Negative Control (Selectivity)	Potent MAO Inhibition (CNS toxicity).	Low Affinity for MAO-A/B (IC50 > 100 µM).
Rifampicin	Synergy Control	CYP450 Induction.	No antagonism in combination assays.
Tamoxifen/Doxorubicin	Cytotoxicity Control	High mammalian cell toxicity.	High Selectivity Index (SI > 10 vs. HepG2 cells).

Key Selectivity Metrics

- Selectivity Index (SI): Defined as
 - . An SI > 10 is considered a "hit"; SI > 50 is a "lead".
- Resistance Factor (RF): Defined as
 - . An RF ~ 1 indicates the compound bypasses standard resistance mechanisms.

Part 3: Experimental Framework

To generate a publishable selectivity profile, you must execute a "Triad of Validation": Efficacy, Mammalian Safety, and Off-Target Profiling.

Protocol A: Antimycobacterial Potency (MABA Assay)

Objective: Determine Minimum Inhibitory Concentration (MIC) against *M. tuberculosis* H37Rv and MDR clinical isolates.

- Inoculum Prep: Culture *M. tuberculosis* H37Rv in Middlebrook 7H9 broth supplemented with OADC to mid-log phase (OD600 ~ 0.6). Dilute to 1:100.
- Plate Setup: Use sterile 96-well plates. Add 100 μ L of Middlebrook 7H9 medium to all wells.
- Compound Dilution: Perform serial 2-fold dilutions of 5-MNH derivatives (range: 100 μ g/mL to 0.09 μ g/mL). Include INH as a control.
- Incubation: Add 100 μ L of bacterial suspension to wells. Incubate at 37°C for 5 days.
- Readout (Alamar Blue): Add 20 μ L of Alamar Blue (resazurin) reagent and 12 μ L of 10% Tween 80. Incubate for 24 hours.
 - Blue: No growth (Inhibition).
 - Pink: Growth (Reduction of resazurin).
- Calculation: The lowest concentration preventing the color change is the MIC.

Protocol B: Hepatotoxicity Screening (MTT Assay)

Objective: Assess mammalian cytotoxicity on HepG2 (human liver carcinoma) cells to predict liver safety.

- Seeding: Seed HepG2 cells at

cells/well in 96-well plates containing DMEM + 10% FBS. Incubate 24h for attachment.

- Treatment: Replace medium with fresh media containing 5-MNH compounds at graded concentrations (1–500 μ M).
- Exposure: Incubate for 48 hours at 37°C, 5% CO₂.
- MTT Addition: Add 20 μ L MTT solution (5 mg/mL in PBS). Incubate 4 hours.
- Solubilization: Aspirate media; add 100 μ L DMSO to dissolve formazan crystals.
- Measurement: Read absorbance at 570 nm.
- Analysis: Calculate
(Concentration lethal to 50% of cells).
 - Criterion: A viable drug candidate should have a

Protocol C: MAO-A/B Inhibition (Selectivity Counterscreen)

Objective: Ensure the nicotinic scaffold does not inhibit Monoamine Oxidase, preventing CNS side effects (serotonin syndrome/hypertensive crisis).

- Enzyme Source: Recombinant Human MAO-A and MAO-B (commercially available).
- Substrate: Tyramine or a fluorogenic substrate (e.g., p-tyramine).
- Reaction:
 - Mix 5-MNH compound (10 μ M fixed dose for screening) with enzyme in potassium phosphate buffer (pH 7.4).
 - Incubate 15 mins at 37°C.
 - Add substrate to initiate reaction.

- Detection: Measure H₂O₂ production using an Amplex Red coupled assay (Fluorescence Ex/Em 530/590 nm).
- Validation:
 - Clorgyline (MAO-A specific inhibitor) and Deprenyl (MAO-B specific inhibitor) must be used as positive controls.
 - Success Metric: < 50% inhibition at 10 μM indicates acceptable selectivity.

Part 4: Data Analysis & Visualization

Screening Cascade Workflow

This diagram represents the decision logic for advancing a 5-MNH hit.

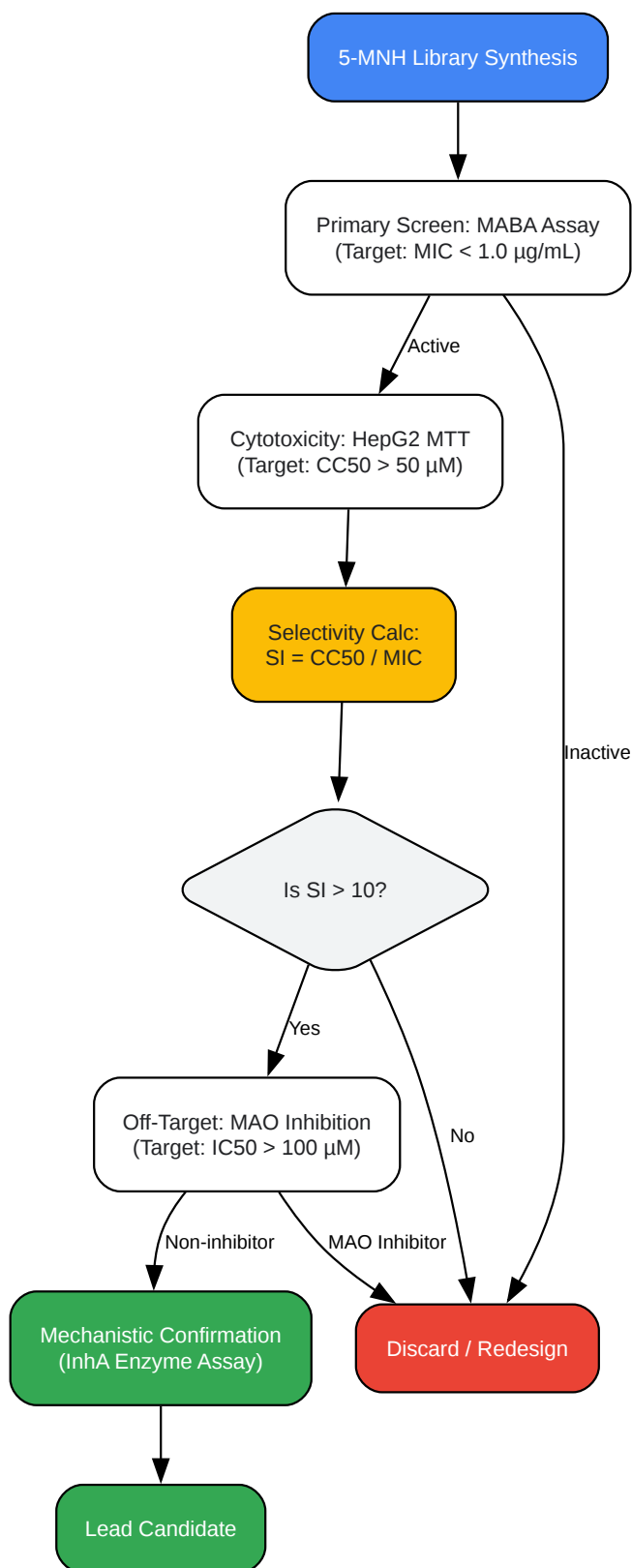

[Click to download full resolution via product page](#)

Caption: Sequential screening cascade ensuring only potent, non-toxic, and selective compounds advance.

Sample Data Presentation

When publishing, summarize your findings in a comparative table format:

Compound ID	MIC (H37Rv) [µg/mL]	MIC (MDR-TB) [µg/mL]	CC50 (HepG2) [µM]	SI (HepG2)	MAO-A Inhibition % (10µM)
INH (Control)	0.05	> 10.0	250	5000	< 5%
Isoniazid	2.00	2.00	150	75	95% (Fail)
5-MNH-01	0.10	0.12	200	2000	10%
5-MNH-02	0.08	0.08	45	562	8%

References

- Design, Synthesis and Antitubercular Activity of Certain Nicotinic Acid Hydrazides. *Molecules*. (2015). Comparison of 5-substituted nicotinohydrazides and their activity against M. tuberculosis. [[Link](#)][1]
- Mechanisms of Isoniazid Resistance in Mycobacterium tuberculosis. *Clinical Microbiology Reviews*. (2020). Detailed review of katG and inhA pathways. [[Link](#)]
- Monoamine Oxidase Inhibitors: A Review of Their Anti-Inflammatory Therapeutic Potential and Mechanisms of Action. *Frontiers in Pharmacology*. (2018). Discusses the off-target pharmacology of hydrazide derivatives. [[Link](#)]
- Cytotoxicity of 5-Methoxysterigmatocystin in HepG2 Cells. *Toxins*. (2020). Provides methodological context for assessing cytotoxicity of 5-methoxy substituted compounds in liver cells.[1][2] [[Link](#)]
- Microplate Alamar Blue Assay (MABA) for the High-throughput Screening of Anti-TB Compounds. *Nature Protocols*. (2011). The standard protocol for MIC determination. [[Link](#)]

Need Custom Synthesis?

BenchChem offers custom synthesis for rare earth carbides and specific isotopic labeling.

Email: info@benchchem.com or [Request Quote Online](#).

Sources

- [1. Design, Synthesis and Antitubercular Activity of Certain Nicotinic Acid Hydrazides - PMC \[pmc.ncbi.nlm.nih.gov\]](#)
- [2. Sterigmatocystin, 5-Methoxysterigmatocystin, and Their Combinations are Cytotoxic and Genotoxic to A549 and HepG2 Cells and Provoke Phosphorylation of Chk2, but not FANCD2 Checkpoint Proteins - PMC \[pmc.ncbi.nlm.nih.gov\]](#)
- To cite this document: BenchChem. [Assessing the Selectivity of 5-Methoxynicotinohydrazide-Based Compounds: A Comparative Guide]. BenchChem, [2026]. [Online PDF]. Available at: [\[https://www.benchchem.com/product/b13677600/docs#assessing-the-selectivity-of-5-methoxynicotinohydrazide-based-compounds-a-comparative-guide\]](https://www.benchchem.com/product/b13677600/docs#assessing-the-selectivity-of-5-methoxynicotinohydrazide-based-compounds-a-comparative-guide)

Disclaimer & Data Validity:

The information provided in this document is for Research Use Only (RUO) and is strictly not intended for diagnostic or therapeutic procedures. While BenchChem strives to provide accurate protocols, we make no warranties, express or implied, regarding the fitness of this product for every specific experimental setup.

Technical Support: The protocols provided are for reference purposes. Unsure if this reagent suits your experiment?

Need Industrial/Bulk Grade? [Request Custom Synthesis Quote](#)

BenchChem

Our mission is to be the trusted global source of essential and advanced chemicals, empowering scientists and researchers to drive progress in science and industry.

Contact

Address: 3281 E Guasti Rd

Ontario, CA 91761, United States

Phone: (601) 213-4426

Email: info@benchchem.com

[Contact our Ph.D. Support Team for a compatibility check](#)