

# Technical Support Center: Troubleshooting Low Conversion Rates in Amination Reactions

**Author:** BenchChem Technical Support Team. **Date:** May 2026

## Compound of Interest

Compound Name: *Methyl 2-amino-4,5-difluorobenzoate*

CAS No.: *207346-42-7*

Cat. No.: *B1369903*

[Get Quote](#)

Welcome to the technical support center for amination reactions. This guide is designed for researchers, scientists, and drug development professionals to diagnose and resolve common issues leading to low conversion rates in two of the most prevalent amination methodologies: Palladium-Catalyzed Buchwald-Hartwig Amination and Reductive Amination. Our goal is to provide in-depth, actionable insights rooted in mechanistic understanding to help you optimize your reaction outcomes.

## Section 1: Palladium-Catalyzed Buchwald-Hartwig Amination

The Buchwald-Hartwig amination is a cornerstone of modern organic synthesis for forming carbon-nitrogen (C-N) bonds.[1] However, its sensitivity to various reaction parameters can often lead to frustratingly low yields.[2] This section will address the most common failure points in a question-and-answer format.

## Frequently Asked Questions (FAQs) & Troubleshooting Guide

Q1: My Buchwald-Hartwig reaction shows low or no conversion. What are the most common initial checks?

Low conversion in a Buchwald-Hartwig amination can stem from several factors, as the reaction is known to be sensitive to reaction conditions.<sup>[2]</sup> Here are the primary areas to investigate:

- **Inert Atmosphere:** The active Pd(0) catalytic species is highly sensitive to oxygen.<sup>[2][3]</sup> Ensure your reaction vessel was properly degassed and maintained under an inert atmosphere (Argon or Nitrogen) throughout the setup and reaction.<sup>[2]</sup>
- **Reagent and Solvent Quality:** The purity and dryness of your reagents and solvent are critical.<sup>[2]</sup> Trace water or other impurities can deactivate the catalyst.<sup>[3]</sup> It is recommended to use anhydrous, degassed solvents.<sup>[3]</sup>
- **Catalyst Activity:** The palladium source and ligand are central to the reaction's success. If you are generating the catalyst in situ from a Pd(II) source like Pd(OAc)<sub>2</sub>, the reduction to the active Pd(0) species might be inefficient. Using commercially available, air-stable Pd(II) precatalysts (e.g., G3 or G4 Buchwald precatalysts) is often more reliable.<sup>[4]</sup>

Q2: I'm using an aryl chloride and observing very low yield. What should I change first?

Aryl chlorides are notoriously less reactive than their bromide or iodide counterparts due to the strength of the C-Cl bond, which makes the oxidative addition step of the catalytic cycle more difficult.<sup>[2][4]</sup> For these challenging substrates, the choice of ligand is paramount.<sup>[4]</sup>

- **Ligand Selection:** Switch to a state-of-the-art, sterically demanding, and electron-rich dialkylbiaryl phosphine ligand.<sup>[4]</sup> Ligands like BrettPhos and RuPhos have demonstrated success with electron-deficient and sterically hindered amines and aryl chlorides.<sup>[5][6]</sup>

Q3: How do I choose the right base for my Buchwald-Hartwig reaction?

The base plays a crucial role in deprotonating the amine, a key step in the catalytic cycle.<sup>[4][7]</sup> The choice of base is highly dependent on the solvent and the functional group tolerance of

your substrates.[7][8][9]

Base Type	Examples	Advantages	Disadvantages
Strong Bases	NaOtBu, LHMDS	Often lead to higher reaction rates.[2]	Incompatible with base-sensitive functional groups.[2]
Weaker Bases	CS <sub>2</sub> CO <sub>3</sub> , K <sub>3</sub> PO <sub>4</sub>	Broader functional group tolerance.[2]	May result in slower reaction rates.[2]

In nonpolar solvents, an anionic base is generally required to deprotonate the neutral palladium-amine complex.[7][9] In polar solvents, care must be taken as the base can sometimes form an overly stable complex with the palladium, hindering catalysis.[8][9]

Q4: My starting materials are not fully dissolving. Could this be the issue?

Absolutely. Poor solubility of reagents, especially the inorganic base, is a frequent and often underestimated cause of reaction failure.[2][10] The primary role of the solvent is to solubilize all reaction components.[2]

- Common Solvents: Aprotic polar solvents like dioxane and THF, or aromatic hydrocarbons such as toluene, are commonly used.[2]
- Troubleshooting Solubility: If you suspect solubility issues, consider switching to a solvent system that better solubilizes all components. For instance, in some cases, changing from toluene to dioxane has been shown to significantly improve yields, likely due to better solubility of the reaction intermediates.[2]

## Visualizing the Troubleshooting Workflow

A systematic approach is key to diagnosing issues with your amination reaction. The following workflow can guide your troubleshooting efforts.

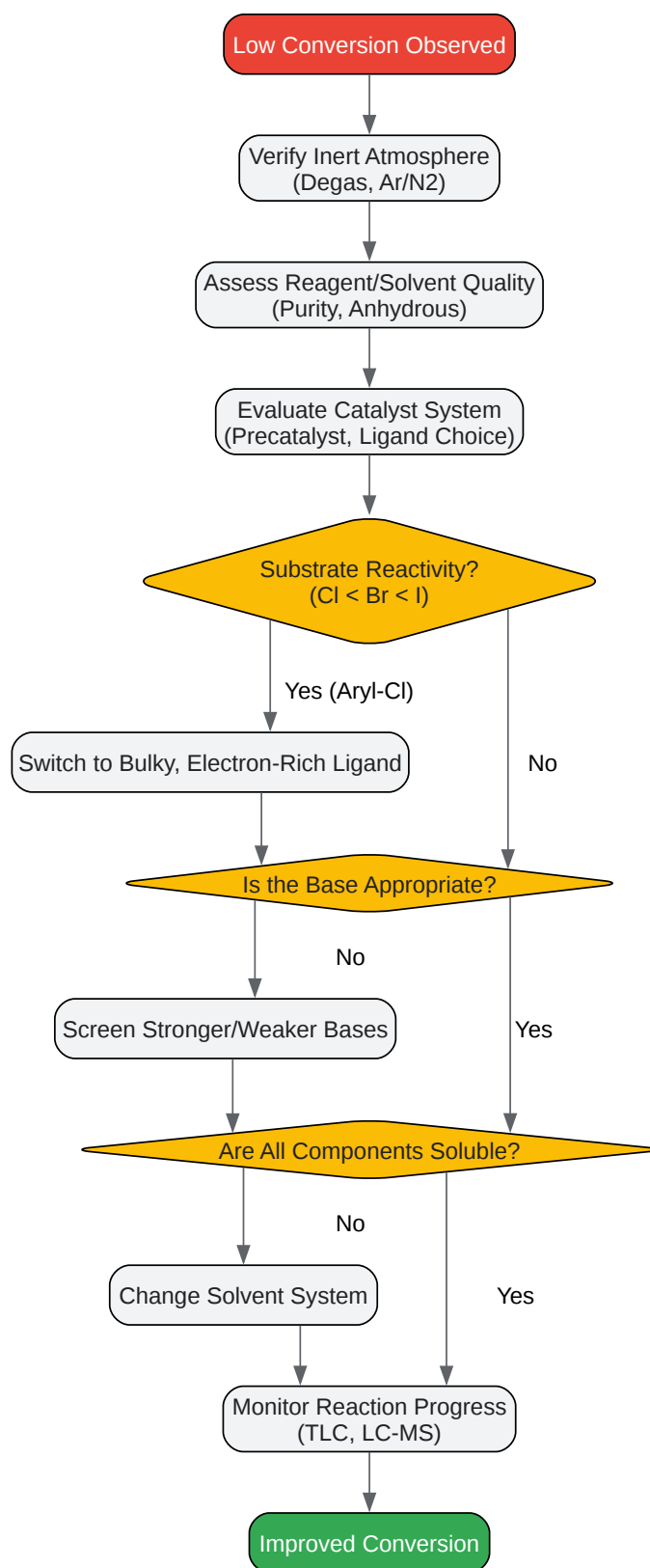

[Click to download full resolution via product page](#)

Caption: A troubleshooting workflow for low conversion in Buchwald-Hartwig amination.

## Experimental Protocol: Screening for Optimal Conditions

When facing a challenging substrate, a systematic screening of reaction parameters is often the most efficient path to success.<sup>[11]</sup>

Step-by-Step Guide for Ligand and Base Screening:

- **Setup:** In a glovebox, arrange an array of reaction vials. To each vial, add the aryl halide (1.0 equiv), the palladium precursor (e.g., Pd<sub>2</sub>(dba)<sub>3</sub>, 1-2 mol%), and the specific phosphine ligand to be tested (2-4 mol%).
- **Addition of Amine and Base:** Add the amine (1.2 equiv) and the base (1.5-2.0 equiv) to each vial.
- **Solvent Addition:** Dispense the anhydrous, degassed solvent into each vial.
- **Reaction:** Seal the vials and place them in a heating block set to the desired temperature (typically 80-110 °C).
- **Monitoring:** After a set time, take an aliquot from each reaction, quench, and analyze by LC-MS or GC-MS to determine conversion.<sup>[12][13][14]</sup>

## Section 2: Reductive Amination

Reductive amination is a widely used method for the synthesis of amines from carbonyl compounds and ammonia or primary or secondary amines.<sup>[15][16]</sup> It typically proceeds via an intermediate imine or iminium ion, which is then reduced.<sup>[17]</sup> While generally robust, low conversion rates can occur due to several factors.

## Frequently Asked Questions (FAQs) & Troubleshooting Guide

Q1: My one-pot reductive amination is giving low yields. What's the likely problem?

In a one-pot reductive amination, the formation of the imine and its reduction occur concurrently.<sup>[15]</sup> A common issue is the premature reduction of the starting aldehyde or ketone

by the reducing agent before the imine has had a chance to form.[17]

- Choice of Reducing Agent: Sodium cyanoborohydride ( $\text{NaBH}_3\text{CN}$ ) and sodium triacetoxyborohydride ( $\text{NaBH}(\text{OAc})_3$ ) are often preferred over sodium borohydride ( $\text{NaBH}_4$ ) for one-pot reactions.[17][18] This is because they are less reactive towards carbonyls at neutral or slightly acidic pH, allowing for the selective reduction of the imine/iminium ion intermediate.[15][17]

Q2: I'm performing a stepwise reductive amination, but the overall yield is still low. What should I investigate?

In a stepwise, or indirect, reductive amination, the imine is formed first and then reduced in a separate step.[15] If you are experiencing low yields with this method, consider the following:

- Imine Formation Equilibrium: The formation of the imine from the carbonyl and amine is an equilibrium process that produces water.[15] If water is not removed, the equilibrium may not favor the imine, leading to low conversion. Consider using a Dean-Stark apparatus or adding a dehydrating agent.
- pH Control: Imine formation is typically favored under mildly acidic conditions (pH 4-5).[16] [17] If the pH is too low, the amine nucleophile will be protonated and non-nucleophilic. If the pH is too high, the carbonyl will not be sufficiently activated.[17]

Q3: Can side reactions be a cause of low conversion in my reductive amination?

Yes, several side reactions can compete with the desired amination pathway.

- Over-alkylation: Primary amines can react with the aldehyde/ketone to form a secondary amine, which can then react again to form a tertiary amine.[17] This is a common issue when trying to synthesize secondary amines.
- Aldol or Other Carbonyl Condensations: Under certain conditions, especially with enolizable aldehydes or ketones, self-condensation reactions can occur.

## Visualizing the Reductive Amination Logic

The choice between a one-pot or stepwise procedure depends on the reactivity of your substrates and the desired selectivity.

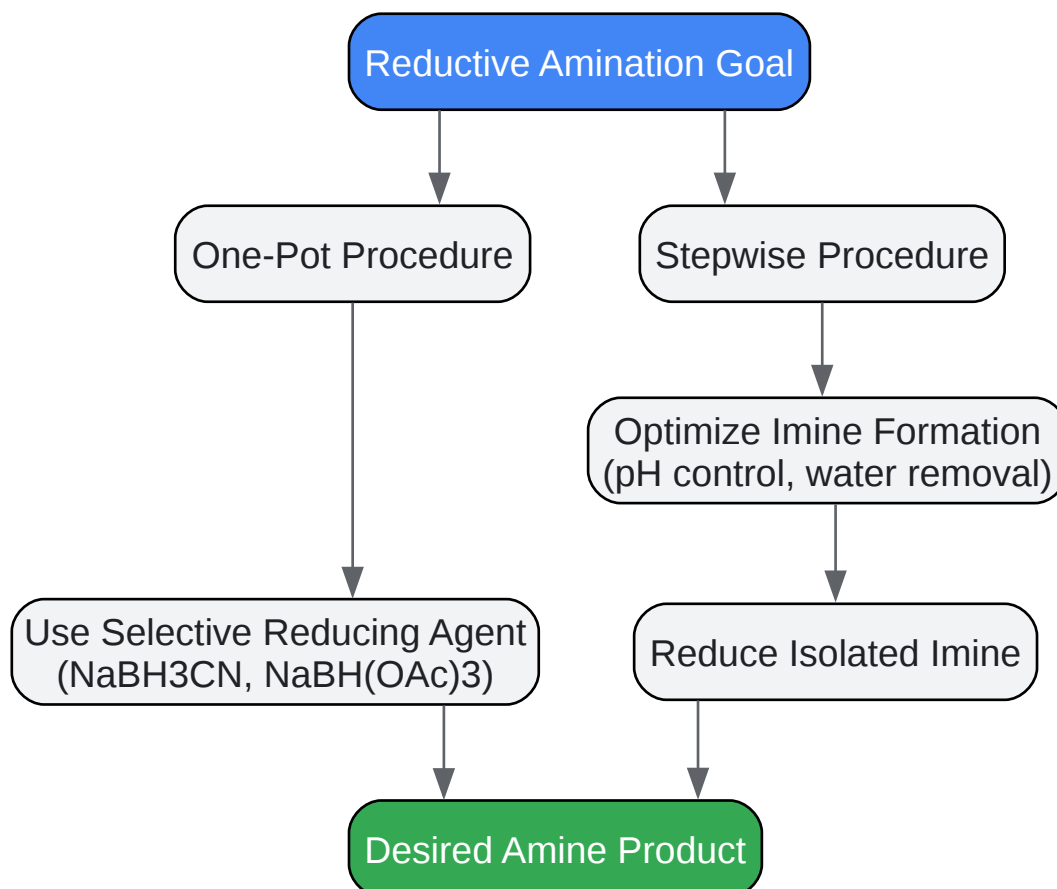

[Click to download full resolution via product page](#)

Caption: Decision logic for one-pot vs. stepwise reductive amination.

## Experimental Protocol: Monitoring Reaction Progress

Careful monitoring of your reaction is crucial for troubleshooting and optimization. Thin-layer chromatography (TLC) is a simple and effective method for this purpose.[19][20]

Step-by-Step Guide for TLC Monitoring:

- Prepare the TLC Plate: Draw a baseline with a pencil on a silica gel TLC plate.
- Spotting: Using a capillary tube, spot the starting material(s) and the reaction mixture on the baseline.

- Development: Place the TLC plate in a developing chamber containing an appropriate solvent system (e.g., a mixture of hexane and ethyl acetate).
- Visualization: After the solvent front has moved up the plate, remove it and visualize the spots under a UV lamp or by using a chemical stain (e.g., potassium permanganate).[20] The disappearance of the starting material spot and the appearance of a new product spot indicate that the reaction is proceeding.[19]

## References

- Wikipedia. (n.d.). Reductive amination. Retrieved from [\[Link\]](#)
- Wikipedia. (n.d.). Buchwald–Hartwig amination. Retrieved from [\[Link\]](#)
- Sunesson, Y., Limé, E., Nilsson Lill, S. O., Meadows, R. E., & Norrby, P.-O. (2014). Role of the Base in Buchwald–Hartwig Amination. *The Journal of Organic Chemistry*, 79(24), 11961–11969. Retrieved from [\[Link\]](#)
- Sunesson, Y., Limé, E., Nilsson Lill, S. O., Meadows, R. E., & Norrby, P.-O. (2014). Role of the base in Buchwald-Hartwig amination. PubMed. Retrieved from [\[Link\]](#)
- Thomas, G. T., Janusson, E., Zijlstra, H. S., & McIndoe, J. S. (2019). Step-by-step real time monitoring of a catalytic amination reaction. *Chemical Science*. Retrieved from [\[Link\]](#)
- Fletcher, S. A., & Organ, M. G. (2016). Amination of Aryl Halides and Esters Using Intensified Continuous Flow Processing. *Molecules*, 21(12), 1759. Retrieved from [\[Link\]](#)
- Ai, H.-J., Kim, S.-T., Liu, C., & Buchwald, S. L. (2024). Copper-Catalyzed Amination of Aryl Chlorides under Mild Reaction Conditions. *Journal of the American Chemical Society*, 146(38), 25950–25955. Retrieved from [\[Link\]](#)
- Ashenurst, J. (2017). Reductive Amination, and How It Works. *Master Organic Chemistry*. Retrieved from [\[Link\]](#)
- Zhang, Y., et al. (2021). How the substrate affects amination reaction kinetics of nitrochlorobenzene. *Reaction Chemistry & Engineering*. Retrieved from [\[Link\]](#)

- Organic Chemistry Portal. (n.d.). Arylamine synthesis by amination (arylation). Retrieved from [\[Link\]](#)
- Thomas, G. T., Janusson, E., Zijlstra, H. S., & McIndoe, J. S. (2019). Step-by-Step Real Time Monitoring of a Catalytic Amination Reaction. ChemRxiv. Retrieved from [\[Link\]](#)
- Chemistry LibreTexts. (2023). Buchwald-Hartwig Amination. Retrieved from [\[Link\]](#)
- Sunesson, Y., Limé, E., Nilsson Lill, S. O., Meadows, R. E., & Norrby, P.-O. (2014). The Role of the Base in Buchwald-Hartwig Amination. ResearchGate. Retrieved from [\[Link\]](#)
- Fors, B. P., & Buchwald, S. L. (2010). Palladium-Catalyzed Amination of Aryl Halides with Aqueous Ammonia and Hydroxide Base Enabled by a New Ligand. eScholarship. Retrieved from [\[Link\]](#)
- Thomas, G. T., Janusson, E., Zijlstra, H. S., & McIndoe, J. S. (2019). Step-by-Step Real Time Monitoring of a Catalytic Amination Reaction. Amazon S3. Retrieved from [\[Link\]](#)
- Abdel-Magid, A. F., Carson, K. G., Harris, B. D., Maryanoff, C. A., & Shah, R. D. (1996). Reductive Amination of Aldehydes and Ketones with Sodium Triacetoxyborohydride. Studies on Direct and Indirect Reductive Amination Procedures. *The Journal of Organic Chemistry*, 61(11), 3849–3862. Retrieved from [\[Link\]](#)
- Ruiz-Castillo, P., & Buchwald, S. L. (2020). Development of an Aryl Amination Catalyst with Broad Scope Guided by Consideration of Catalyst Stability. DSpace@MIT. Retrieved from [\[Link\]](#)
- Neilson, B. M., & Bielawski, C. W. (2013). Regioselective Palladium-Catalyzed Chain-Growth Allylic Amination Polymerization of Vinyl Aziridines. *Journal of the American Chemical Society*, 135(33), 12331–12334. Retrieved from [\[Link\]](#)
- Organic Chemistry Data. (n.d.). Reductive Amination - Common Conditions. Retrieved from [\[Link\]](#)
- Gensch, T., et al. (2022). Design and Application of a Screening Set for Monophosphine Ligands in Cross-Coupling. NSF Public Access Repository. Retrieved from [\[Link\]](#)

- Reddit. (2018). Help troubleshooting a Buchwald-Hartwig amination? Retrieved from [[Link](#)]
- Zhang, Y., et al. (2021). How the substrate affects amination reaction kinetics of nitrochlorobenzene. ResearchGate. Retrieved from [[Link](#)]
- Ruiz-Castillo, P., & Buchwald, S. L. (2020). Development of an Aryl Amination Catalyst with Broad Scope Guided by Consideration of Catalyst Stability. PMC - NIH. Retrieved from [[Link](#)]
- ResearchGate. (2017). How to monitor the progress of the reaction of reductive amination of D-maltose with aliphatic amines? Retrieved from [[Link](#)]
- Enamine Germany. (n.d.). Catalyst screening. Retrieved from [[Link](#)]
- Organic Chemistry Tutor. (n.d.). Reductive Amination. Retrieved from [[Link](#)]
- Ruiz-Castillo, P., Blackmond, D. G., & Buchwald, S. L. (2015). Rational Ligand Design for the Arylation of Hindered Primary Amines Guided by Reaction Progress Kinetic Analysis. Journal of the American Chemical Society, 137(8), 3085–3092. Retrieved from [[Link](#)]
- ResearchGate. (n.d.). Ligands used in the reaction screening. Retrieved from [[Link](#)]
- Reddit. (2025). What's wrong with my reductive amination? I barely got any product. Retrieved from [[Link](#)]
- ResearchGate. (2006). Study of a New Rate Increasing “Base Effect” in the Palladium-Catalyzed Amination of Aryl Iodides. Retrieved from [[Link](#)]
- Wiley Analytical Science. (2019). Palladium Catalyzed Amination of Aryl Chlorides. Retrieved from [[Link](#)]
- Chemistry Stack Exchange. (2022). Buchwald-Hartwig coupling troubleshooting. Retrieved from [[Link](#)]
- ResearchGate. (n.d.). Substrate scope of intramolecular amination. Retrieved from [[Link](#)]
- ResearchGate. (n.d.). Substrate scope of the amination. Reaction conditions. Retrieved from [[Link](#)]

- Myers, A. (n.d.). Chem 115. Retrieved from [[Link](#)]
- ResearchGate. (n.d.). Substrate scope of aldehydes and amines for reductive amination. Standard conditions. Retrieved from [[Link](#)]

### Need Custom Synthesis?

BenchChem offers custom synthesis for rare earth carbides and specific isotopic labeling.

Email: [info@benchchem.com](mailto:info@benchchem.com) or [Request Quote Online](#).

## Sources

- 1. [Buchwald–Hartwig amination - Wikipedia \[en.wikipedia.org\]](#)
- 2. [pdf.benchchem.com \[pdf.benchchem.com\]](#)
- 3. [pdf.benchchem.com \[pdf.benchchem.com\]](#)
- 4. [pdf.benchchem.com \[pdf.benchchem.com\]](#)
- 5. [pubs.acs.org \[pubs.acs.org\]](#)
- 6. [pdf.benchchem.com \[pdf.benchchem.com\]](#)
- 7. [researchgate.net \[researchgate.net\]](#)
- 8. [pubs.acs.org \[pubs.acs.org\]](#)
- 9. [Role of the base in Buchwald-Hartwig amination - PubMed \[pubmed.ncbi.nlm.nih.gov\]](#)
- 10. [Chemical Insights | How to Wisely Design Conditions for Buchwald-Hartwig Couplings ? - RCS Research Chemistry Services \[rcs.wuxiapptec.com\]](#)
- 11. [enamine.de \[enamine.de\]](#)
- 12. [web.uvic.ca \[web.uvic.ca\]](#)
- 13. [chemrxiv.org \[chemrxiv.org\]](#)
- 14. [s3-eu-west-1.amazonaws.com \[s3-eu-west-1.amazonaws.com\]](#)
- 15. [Reductive amination - Wikipedia \[en.wikipedia.org\]](#)
- 16. [organicchemistrytutor.com \[organicchemistrytutor.com\]](#)
- 17. [masterorganicchemistry.com \[masterorganicchemistry.com\]](#)
- 18. [Reductive Amination - Common Conditions \[commonorganicchemistry.com\]](#)

- [19. researchgate.net \[researchgate.net\]](#)
- [20. pdf.benchchem.com \[pdf.benchchem.com\]](#)
- To cite this document: BenchChem. [Technical Support Center: Troubleshooting Low Conversion Rates in Amination Reactions]. BenchChem, [2026]. [Online PDF]. Available at: [<https://www.benchchem.com/product/b1369903/docs#technical-support-center-troubleshooting-low-conversion-rates-in-amination-reactions>]

---

### Disclaimer & Data Validity:

The information provided in this document is for Research Use Only (RUO) and is strictly not intended for diagnostic or therapeutic procedures. While BenchChem strives to provide accurate protocols, we make no warranties, express or implied, regarding the fitness of this product for every specific experimental setup.

**Technical Support:** The protocols provided are for reference purposes. Unsure if this reagent suits your experiment?

**Need Industrial/Bulk Grade?** [Request Custom Synthesis Quote](#)

## BenchChem

Our mission is to be the trusted global source of essential and advanced chemicals, empowering scientists and researchers to drive progress in science and industry.

### Contact

Address: 3281 E Guasti Rd  
Ontario, CA 91761, United States  
Phone: (601) 213-4426  
Email: [info@benchchem.com](mailto:info@benchchem.com)

[Contact our Ph.D. Support Team for a compatibility check](#)