

Application Note: Optimized Coupling Strategies for 2-Bromo-6-phthalimidohexanoic Acid

Author: BenchChem Technical Support Team. **Date:** May 2026

Compound of Interest

Compound Name: 2-Bromo-6-phthalimidohexanoic acid
Cat. No.: B13666487

[Get Quote](#)

-Bromo-

-Phthalimido Carboxylic Acids

Part 1: Executive Summary & Mechanistic Insight

The Challenge: A "Tug-of-War" Reactivity

Coupling **2-Bromo-6-phthalimidohexanoic acid** (Compound 1) with amines presents a unique chemoselective challenge not found in standard peptide synthesis. The molecule contains three reactive centers that must be managed:

- Carboxylic Acid (Target): Requires activation for nucleophilic acyl substitution.
- -Bromine (Electrophile): Highly susceptible to SN2 displacement by the incoming amine.
- Phthalimide (Protecting Group): Susceptible to nucleophilic ring-opening by primary amines (aminolysis) if reaction times are prolonged.

The "Race" Mechanism

Success depends on winning the kinetic race between Acylation (desired amide bond) and Alkylation (undesired SN2).

- Pathway A (Desired): The amine attacks the activated carbonyl. Rate depends on the quality of the leaving group (e.g., -OBt, -Cl).
- Pathway B (Undesired): The amine attacks the

-carbon, displacing bromide. This generates a secondary amine byproduct which can then couple to another acid molecule, creating a dimer.

Key Directive: You must pre-activate the carboxylic acid. Adding the amine to a mixture of acid and coupling reagent before activation is complete increases the local concentration of free amine relative to the active ester, favoring the SN2 side reaction.

Part 2: Experimental Protocols

Protocol A: High-Fidelity HATU Coupling (Recommended)

Best for: Valuable amines, PROTAC linker synthesis, and maintaining stereochemical integrity (if chiral). Mechanism: HATU generates a highly reactive At-ester (7-azabenzotriazol-1-yl ester) that reacts faster with amines than the

-bromide does.

Materials

- Substrate: **2-Bromo-6-phthalimidohexanoic acid** (1.0 equiv)
- Amine: Target amine (R-NH

) (1.1 equiv)
- Reagent: HATU (1.1 – 1.2 equiv)
- Base: DIPEA (N,N-Diisopropylethylamine) (2.5 – 3.0 equiv)
- Solvent: Anhydrous DMF or DMAc (0.1 M concentration)

Step-by-Step Procedure

- Pre-Activation (CRITICAL):
 - Dissolve **2-Bromo-6-phthalimidohexanoic acid** and HATU in anhydrous DMF under N atmosphere.
 - Cool the solution to 0 °C in an ice bath.
 - Add DIPEA dropwise.
 - Stir at 0 °C for 15–20 minutes. (Visual cue: Solution often turns yellow/orange).
 - Why? This ensures the carboxylic acid is fully converted to the activated ester before the amine is introduced, eliminating the window for SN2 attack.
- Coupling:
 - Add the amine (dissolved in minimal DMF) dropwise to the pre-activated mixture at 0 °C.
 - Allow the reaction to warm to Room Temperature (RT) naturally.
 - Stir for 2–4 hours.
 - Monitor: Check LCMS for consumption of the active ester. Do not stir overnight unless necessary; prolonged exposure of the phthalimide to primary amines can cause ring opening.
- Workup:
 - Dilute with EtOAc.
 - Wash with 5% LiCl solution (3x) to remove DMF.
 - Wash with 0.5 M HCl (rapidly) to remove excess amine/DIPEA (Avoid prolonged contact with strong acid).
 - Wash with Brine, dry over Na

SO

, and concentrate.[1]

Protocol B: Acid Chloride Method (Scale-Up)

Best for: Sterically hindered amines (anilines), large-scale (>10g) synthesis, or cost-sensitive projects. Risk: Higher risk of racemization if the temperature is not strictly controlled.

Materials

- Reagent: Oxalyl Chloride (1.5 equiv) + catalytic DMF (2-3 drops).
- Solvent: Anhydrous DCM (Dichloromethane).

Step-by-Step Procedure

- Activation:
 - Dissolve the acid in DCM at 0 °C.
 - Add catalytic DMF.
 - Add Oxalyl Chloride dropwise (Gas evolution: CO + CO
).
 - Stir at RT for 1 hour until gas evolution ceases.
 - Evaporation: Concentrate in vacuo to remove excess oxalyl chloride (Critical to prevent side reactions with the amine). Redissolve the crude acid chloride in fresh DCM.
- Coupling:
 - Cool the acid chloride solution to -10 °C (Ice/Salt bath).
 - Add the Amine and TEA (Triethylamine) (1.2 equiv) simultaneously or premixed in DCM.
 - Note: Adding the base/amine slowly at low temp prevents the "ketene" formation pathway which leads to racemization.

Part 3: Troubleshooting & Optimization Data

Issue	Observation (LCMS/NMR)	Root Cause	Solution
N-Alkylation	Mass = Product + Amine - HBr (Secondary amine byproduct)	Amine attacked -Br before coupling.	Increase Pre-activation time. Ensure acid is fully activated before amine addition.
Phthalimide Opening	Mass = Product + 18 (Hydrolysis) or + Amine (Diamide)	Nucleophilic attack on Phthalimide ring.	Reduce reaction time. Avoid primary amine excess. Switch solvent to DCM (less polar).
Racemization	Loss of optical activity (if chiral starting material).	Enolization via -proton abstraction.	Use Collidine or 2,6-Lutidine instead of DIPEA/TEA (weaker bases). Keep temp < 0°C.
Low Conversion	Remaining Active Ester.	Steric hindrance or deactivated amine.	Switch from HATU to COMU or Acid Chloride protocol. Heat to 40°C (risk of side rxn increases).

Part 4: Visualization (Workflow & Pathways)

Diagram 1: Reaction Logic & Competitive Pathways

This diagram illustrates the kinetic competition between the desired Amide Coupling and the undesired SN2 Alkylation.

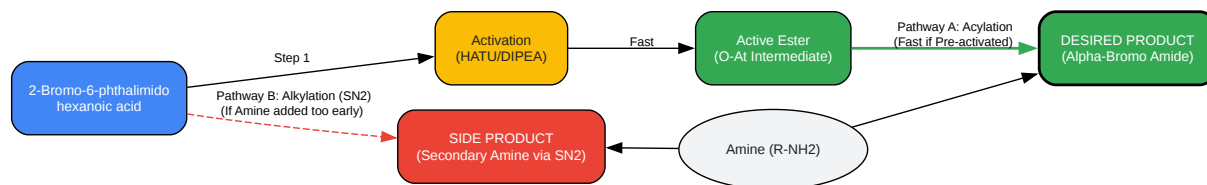

[Click to download full resolution via product page](#)

Caption: Kinetic competition: Pre-activation forces Pathway A (Green), preventing Pathway B (Red).

Diagram 2: Optimized Experimental Workflow

A flowchart for the recommended HATU protocol.

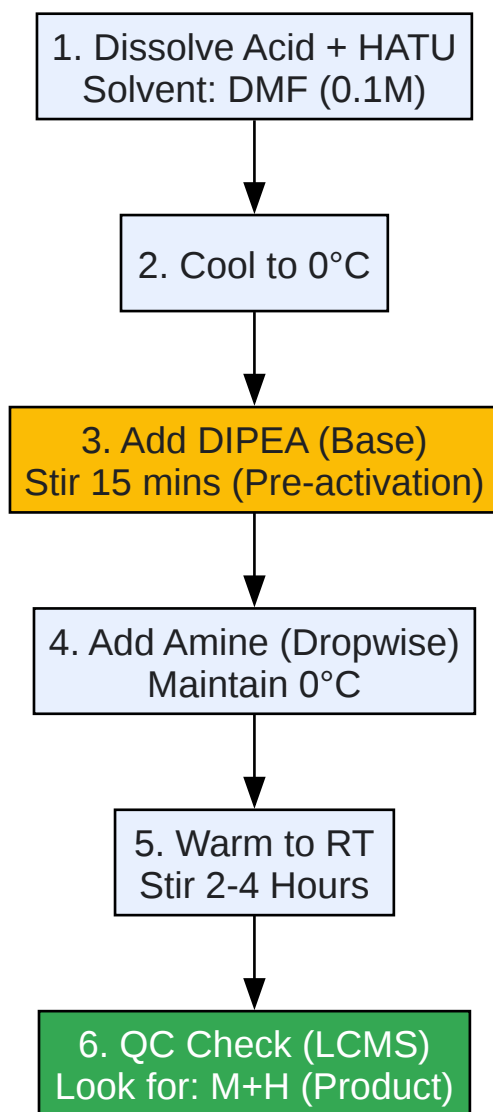

[Click to download full resolution via product page](#)

Caption: Step-by-step execution for the HATU coupling protocol.

Part 5: References

- Valeur, E., & Bradley, M. (2009). Amide bond formation: beyond the myth of coupling reagents. *Chemical Society Reviews*, 38(2), 606-631. [Link](#)
- Dunetz, J. R., Magano, J., & Weisenburger, G. A. (2016). Large-Scale Applications of Amide Coupling Reagents for the Synthesis of Pharmaceuticals. *Organic Process Research & Development*, 20(2), 140–177. [Link](#)

- Montalbetti, C. A., & Falque, V. (2005). Amide bond formation and peptide coupling.[2][3] Tetrahedron, 61(46), 10827-10852. [Link](#)
- Buckley, D. L., et al. (2012). Targeting the von Hippel–Lindau E3 Ubiquitin Ligase Using Small Molecules to Disrupt the VHL/HIF-1 α Interaction. (Context: VHL Linker Synthesis). Journal of the American Chemical Society, 134(36), 15234–15237. [Link](#)
- Joullié, M. M., & Lassen, K. M. (2010). Evolution of Amide Bond Formation. Arkivoc, viii, 189-250. [Link](#)

Need Custom Synthesis?

BenchChem offers custom synthesis for rare earth carbides and specific isotopic labeling.

Email: info@benchchem.com or [Request Quote Online](#).

Sources

- [1. organic-synthesis.com \[organic-synthesis.com\]](https://www.organic-synthesis.com)
- [2. researchgate.net \[researchgate.net\]](https://www.researchgate.net)
- [3. rsc.org \[rsc.org\]](https://www.rsc.org)
- To cite this document: BenchChem. [Application Note: Optimized Coupling Strategies for 2-Bromo-6-phthalimidohexanoic Acid]. BenchChem, [2026]. [Online PDF]. Available at: [\[https://www.benchchem.com/product/b13666487/docs#application-note-optimized-coupling-strategies-for-2-bromo-6-phthalimidohexanoic-acid\]](https://www.benchchem.com/product/b13666487/docs#application-note-optimized-coupling-strategies-for-2-bromo-6-phthalimidohexanoic-acid)

Disclaimer & Data Validity:

The information provided in this document is for Research Use Only (RUO) and is strictly not intended for diagnostic or therapeutic procedures. While BenchChem strives to provide accurate protocols, we make no warranties, express or implied, regarding the fitness of this product for every specific experimental setup.

Technical Support: The protocols provided are for reference purposes. Unsure if this reagent suits your experiment?

Need Industrial/Bulk Grade? [Request Custom Synthesis Quote](#)

BenchChem

Our mission is to be the trusted global source of essential and advanced chemicals, empowering scientists and researchers to drive progress in science and industry.

Contact

Address: 3281 E Guasti Rd
Ontario, CA 91761, United States
Phone: (601) 213-4426
Email: info@benchchem.com

[Contact our Ph.D. Support Team for a compatibility check](#)