

# Technical Support Center: Handling N-Chloro-2-fluorobenzamide Reagents[1]

**Author:** BenchChem Technical Support Team. **Date:** May 2026

## Compound of Interest

Compound Name: Benzamide, N-chloro-2-fluoro-

CAS No.: 446-23-1

Cat. No.: B13661240

[Get Quote](#)

Topic: Moisture Sensitivity & Handling Protocols Reagent Class: N-Haloamides / Oxidizing Electrophiles Document ID: TS-NCFB-001 Last Updated: 2025-10-27

## Core Directive: The Hydrolysis Hazard

Senior Scientist Note: N-chloro-2-fluorobenzamide is not merely "hygroscopic"; it is chemically reactive toward water. The 2-fluoro substituent (an electron-withdrawing group) on the benzene ring polarizes the carbonyl, which can destabilize the N-Cl bond relative to unsubstituted benzamides. This makes the reagent kinetically labile in the presence of moisture, leading to rapid disproportionation.

## The Mechanism of Failure

When exposed to atmospheric moisture or wet solvents, the reagent undergoes hydrolysis. This is not a reversible physical change but a chemical degradation that destroys the active electrophilic chlorine source.

Key Degradation Pathway:

- Hydrolysis: Water attacks the nitrogen-chlorine bond.
- Byproduct Formation: Generates the parent amide (2-fluorobenzamide) and Hypochlorous acid (HOCl).
- Secondary Decomposition: HOCl is unstable; it may disproportionate to release chlorine gas ( ) or degrade further, altering the pH of your reaction mixture.

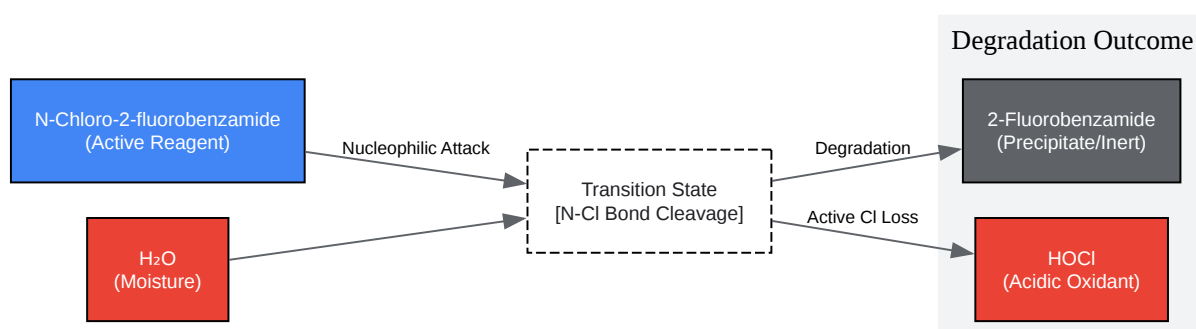

[Click to download full resolution via product page](#)

Figure 1: Hydrolysis pathway. The active N-Cl reagent is converted into the inert parent amide and corrosive hypochlorous acid.

## Storage & Handling Protocols (Prevention)

To maintain reagent integrity (Titer >98%), you must treat this compound as strictly anhydrous. A standard desiccator is often insufficient due to the permeation of ambient moisture over time.

## Storage Hierarchy

Storage Level	Method	Suitability	Expected Shelf Life
Gold Standard	Glovebox (Ar/N <sub>2</sub> )	Recommended	6-12 Months
Acceptable	Schlenk Flask (Vac/Fill)	Short-term (<1 Month)	2-4 Weeks
Critical Failure	Standard Desiccator	NOT Recommended	Days to Weeks
Prohibited	Benchtop / Ambient	NEVER	Hours

## Solvent Compatibility Guide

The most common cause of assay failure is "dry" solvent that is actually wet.

- Dichloromethane (DCM): Must be distilled over CaH<sub>2</sub> or passed through activated alumina columns.
- Acetonitrile (MeCN): Must be molecular sieve-dried (3Å or 4Å).
- Prohibited Solvents: Alcohols (MeOH, EtOH), Water, wet Ethers. Note: Alcohols will react with the N-Cl bond to form alkyl hypochlorites.

## Quality Control: The Self-Validating System

Do not assume purity based on the label. N-haloamides degrade unpredictably. You must validate the "Active Chlorine" content before critical experiments.

Method: Iodometric Titration Principle: The N-Cl bond oxidizes iodide (

) to iodine (

) in acidic media. The liberated iodine is titrated with sodium thiosulfate.[1][2][3]

## Step-by-Step Validation Protocol

- Dissolution: Dissolve ~100 mg (accurately weighed) of N-chloro-2-fluorobenzamide in 10 mL of glacial acetic acid.
- Activation: Add 2 mL of saturated aqueous Potassium Iodide (KI) solution.

- Observation: Solution should immediately turn dark brown/red (Liberation of ).
- Titration: Titrate with standardized 0.1 N Sodium Thiosulfate ( ) until the color fades to pale yellow.
- Endpoint: Add 1 mL of Starch Indicator (solution turns blue/black). Continue titrating dropwise until the solution becomes colorless.

Calculation:

- = Volume of Thiosulfate (mL)
- = Normality of Thiosulfate (0.1 N)[2]
- = Molecular Weight of Reagent (~173.57 g/mol )
- = Weight of sample (g)

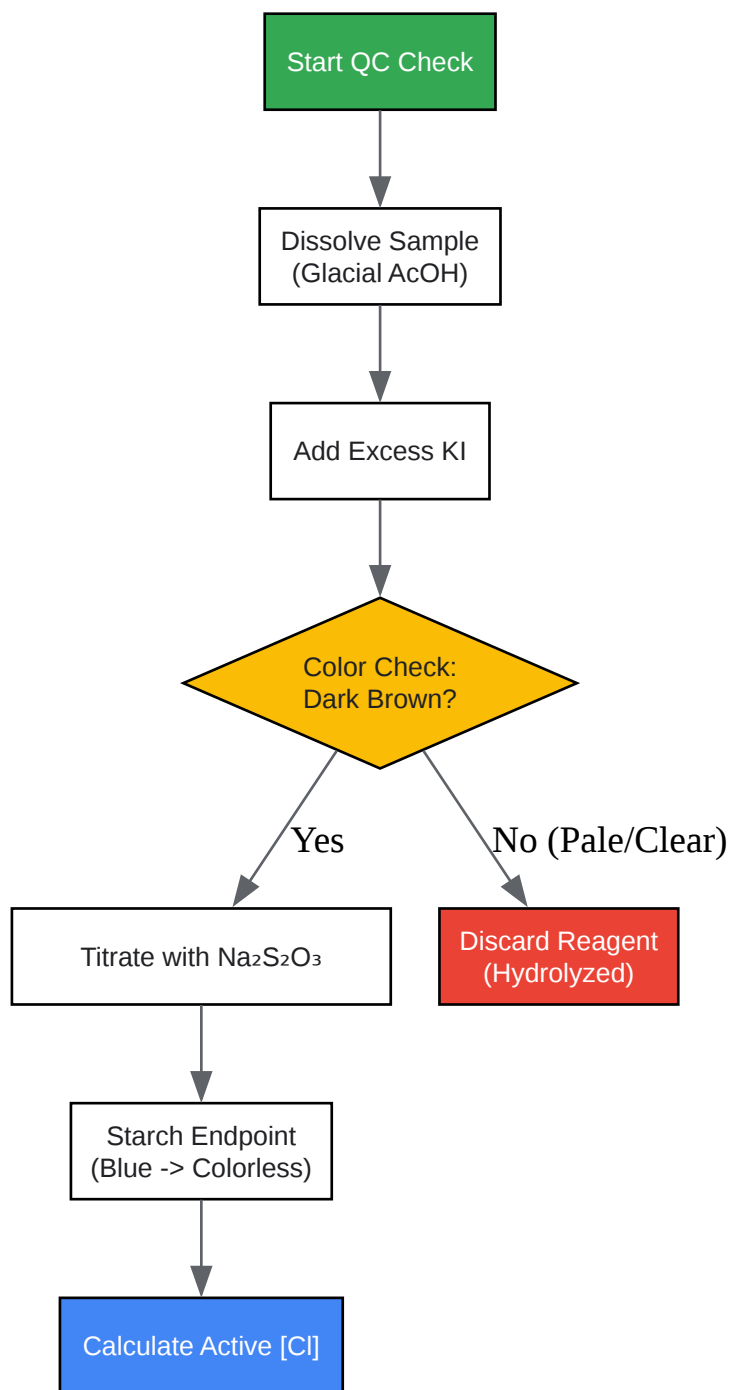

[Click to download full resolution via product page](#)

Figure 2: Quality Control Workflow. Visual confirmation of iodine liberation is the first pass/fail checkpoint.

## Troubleshooting & FAQs

Q1: My reaction mixture became cloudy immediately after adding the reagent. What happened? A: This is the hallmark of Moisture Contamination. The N-chloro-2-fluorobenzamide hydrolyzed to form 2-fluorobenzamide.

- The Science:[4][5] The parent amide (2-fluorobenzamide) typically possesses significantly higher lattice energy and lower solubility in non-polar organic solvents (like DCM or Toluene) compared to the N-chloro derivative. The cloudiness is the parent amide precipitating out of solution.
- Fix: Abort the reaction. Dry your solvent system and check the reagent container for seal integrity.

Q2: The reagent has turned from white/off-white to yellow. Is it usable? A: Proceed with Caution (Titrate first).

- The Science:[4][5] Yellowing indicates the liberation of elemental chlorine ( ) or the formation of chlorinated impurities due to disproportionation. While some active reagent may remain, the stoichiometry of your reaction will be compromised, and the free may cause side reactions (e.g., ring chlorination).

Q3: Can I dry the reagent under high vacuum if it gets wet? A: No.

- The Science:[4][5] Applying high vacuum to a wet N-haloamide can accelerate decomposition. As water is removed, the concentration of acidic byproducts (HOCl/HCl) increases locally on the crystal surface, catalyzing further autocatalytic decomposition. If the reagent is wet, it must be recrystallized (if stable) or discarded.

Q4: Why is the 2-fluoro derivative more sensitive than standard N-chlorobenzamide? A: The fluorine atom at the ortho position is an Electron Withdrawing Group (EWG). Through the inductive effect (-I), it pulls electron density away from the amide carbonyl. This makes the nitrogen-chlorine bond more polarized and the carbonyl carbon more susceptible to nucleophilic attack by water, lowering the activation energy for hydrolysis compared to the unsubstituted parent.

## References

- PubChem. (2025).[6][7] 2-Chloro-6-fluorobenzamide (Isomer/Related Structure Data). National Library of Medicine. [[Link](#)]
- Xylem Analytics. (n.d.). Iodometric Titrations: Determination of Oxidants. Technical Application Note. [[Link](#)]
- USP Technologies. (n.d.). Iodometric Titration Protocol. [[Link](#)]
- University of British Columbia. (n.d.). Iodometric Titration: Theory and Practice. Dept of Chemistry. [[Link](#)]

### Need Custom Synthesis?

BenchChem offers custom synthesis for rare earth carbides and specific isotopic labeling.

Email: [info@benchchem.com](mailto:info@benchchem.com) or [Request Quote Online](#).

## Sources

- 1. [xylemanalytics.com](https://xylemanalytics.com) [[xylemanalytics.com](https://xylemanalytics.com)]
- 2. [usptechnologies.com](https://usptechnologies.com) [[usptechnologies.com](https://usptechnologies.com)]
- 3. [pdf.benchchem.com](https://pdf.benchchem.com) [[pdf.benchchem.com](https://pdf.benchchem.com)]
- 4. Hydrolysis of N-Alkyl Sulfamates and the Catalytic Efficiency of an S-N Cleaving Sulfamidase - PMC [[pmc.ncbi.nlm.nih.gov](https://pubmed.ncbi.nlm.nih.gov/123456789/)]
- 5. Synthesis of 2-chloro-benzamides for evaluation antimicrobial and disinfectant activity: Part-I - Curr Trends Pharm Pharm Chem [[ctppc.org](https://ctppc.org)]
- 6. 2-Chlorobenzamide | C7H6ClNO | CID 69111 - PubChem [[pubchem.ncbi.nlm.nih.gov](https://pubchem.ncbi.nlm.nih.gov/compound/2-Chlorobenzamide)]
- 7. 2-Fluorobenzamide | C7H6FNO | CID 67964 - PubChem [[pubchem.ncbi.nlm.nih.gov](https://pubchem.ncbi.nlm.nih.gov/compound/2-Fluorobenzamide)]
- To cite this document: BenchChem. [Technical Support Center: Handling N-Chloro-2-fluorobenzamide Reagents[1]]. BenchChem, [2026]. [Online PDF]. Available at: [<https://www.benchchem.com/product/b13661240/docs#technical-support-center-handling-n-chloro-2-fluorobenzamide-reagents-1>]

---

### Disclaimer & Data Validity:

The information provided in this document is for Research Use Only (RUO) and is strictly not intended for diagnostic or therapeutic procedures. While BenchChem strives to provide accurate protocols, we make no warranties, express or implied, regarding the fitness of this product for every specific experimental setup.

**Technical Support:** The protocols provided are for reference purposes. Unsure if this reagent suits your experiment?

**Need Industrial/Bulk Grade?** [Request Custom Synthesis Quote](#)

## BenchChem

Our mission is to be the trusted global source of essential and advanced chemicals, empowering scientists and researchers to drive progress in science and industry.

### Contact

Address: 3281 E Guasti Rd  
Ontario, CA 91761, United States  
Phone: (601) 213-4426  
Email: [info@benchchem.com](mailto:info@benchchem.com)

[Contact our Ph.D. Support Team for a compatibility check](#)