

# Technical Support Center: Bromination of 6-Methoxybenzothiazole

**Author:** BenchChem Technical Support Team. **Date:** May 2026

## Compound of Interest

Compound Name: *2,7-Dibromo-6-methoxy-benzothiazole*

Cat. No.: *B13661636*

[Get Quote](#)

## Executive Summary: The Reactivity Landscape[1]

The bromination of 6-methoxybenzothiazole (6-OMe-BTZ) is a deceptively simple transformation that frequently results in complex mixtures.[1] To troubleshoot effectively, you must first identify which reaction manifold you are operating in.

The scaffold presents two distinct reactive centers:[1]

- The Benzene Ring (C7/C5): Activated by the 6-methoxy group towards Electrophilic Aromatic Substitution (EAS).[1]
- The Thiazole Ring (C2): Acidic proton ( ), susceptible to lithiation/quenching or radical functionalization.[1]

Most common user error: Applying standard EAS conditions (

, Fe) when targeting the C2 position, or failing to control temperature/stoichiometry when targeting the benzene ring, leading to inseparable regioisomers.[1]

## Reactivity Map & Decision Tree

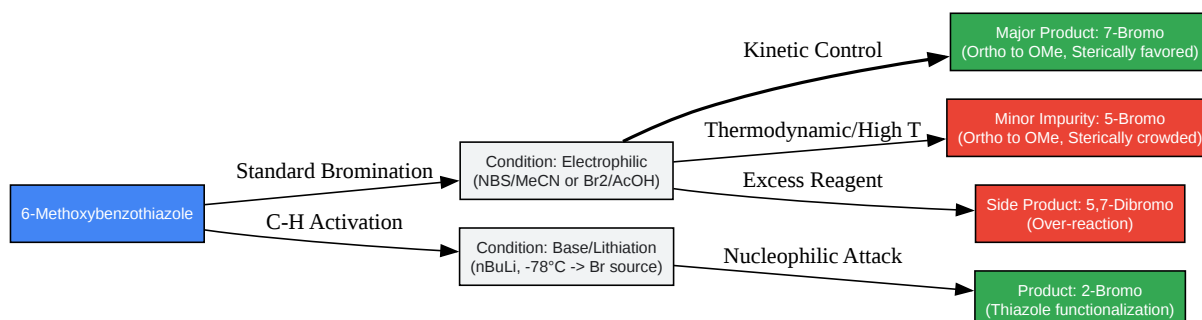

[Click to download full resolution via product page](#)

Figure 1: Reactivity landscape of 6-methoxybenzothiazole.[1] The 6-OMe group strongly activates the benzene ring, making C7 the primary site for electrophilic attack, while C2 requires specific base-mediated conditions.[1]

## Troubleshooting Guides

### Issue 1: The "Mixed Isomer" Nightmare (Regioselectivity)

Symptom: HPLC/NMR shows two monobrominated peaks.[1] You desired the 7-bromo derivative, but have significant 5-bromo contamination. Mechanism: The 6-methoxy group is an ortho, para-director. The para position (C3) is the ring junction (blocked). This leaves two ortho positions: C5 and C7.

- C7: Sterically less hindered and electronically favored in many solvents.
- C5: Flanked by the methoxy group and the C4 proton (buttressing effect), making it sterically crowded.

Variable	Recommendation	Scientific Rationale
Temperature	Maintain < 0°C	Higher temperatures provide enough energy to overcome the steric barrier of C5, increasing the impurity ratio.
Reagent	Use NBS over	is highly reactive and less selective. N-Bromosuccinimide (NBS) provides a slow, controlled release of <a href="#">. [1]</a>
Solvent	Acetonitrile (MeCN)	Polar aprotic solvents often enhance para-like selectivity (relative to the directing group) via specific solvation shells. <a href="#">[1]</a>

#### Corrective Action:

- Switch to NBS in Acetonitrile.
- Run the reaction at -10°C to 0°C.
- If isomers persist, recrystallize from Ethanol/Water (7-bromo isomer is typically less soluble and crystallizes first).[\[1\]](#)

## Issue 2: The "Heavy" Impurity (Over-Bromination)

Symptom: Mass spec shows M+2 peak pattern corresponding to a dibromo species (5,7-dibromo-6-methoxybenzothiazole).[\[1\]](#) Cause: The monobrominated product (7-bromo) is still activated by the methoxy group.[\[1\]](#) If local concentration of brominating agent is high, the second position (C5) will react.[\[1\]](#)

#### Corrective Action:

- Stoichiometry: Use 0.95 equivalents of NBS. It is better to leave 5% starting material (easy to separate) than to generate 5% dibromo impurity (very hard to separate).[1]
- Addition Mode: Add the brominating agent dropwise as a solution. Do not add solid NBS in one portion.

### Issue 3: The "Missing Methyl" (Demethylation)

Symptom: Appearance of a broad -OH peak in IR/NMR; product is soluble in aqueous base.[1]

Cause: Generation of HBr (strong acid) during the reaction cleaves the methyl ether, forming the phenol (6-hydroxybenzothiazole).[1] This is accelerated by Lewis acids (

,

).[1]

Corrective Action:

- Scavengers: Add solid  
  
or  
  
(2-3 equiv) to the reaction mixture to neutralize HBr in situ.[1]
- Avoid Lewis Acids: Do not use iron or aluminum catalysts. The methoxy group activates the ring sufficiently for uncatalyzed bromination.

### Issue 4: Targeting C2 but getting Ring Bromination

Symptom: You want 2-bromo-6-methoxybenzothiazole, but you isolated 7-bromo-6-methoxybenzothiazole. Cause: You used electrophilic conditions (

/AcOH). The benzene ring is more nucleophilic (electron-rich) than the thiazole ring (electron-deficient).[1]

Corrective Action:

- Switch Mechanism: You must use a Lithiation-Quench sequence.
- Protocol: Treat substrate with

-BuLi at  $-78^{\circ}\text{C}$  (deprotonates C2), then quench with a bromine source (e.g.,

or

).<sup>[1]</sup>

## Optimized Experimental Protocol

Target: Synthesis of 7-bromo-6-methoxybenzothiazole (High Selectivity Method).

- Setup: Flame-dry a 100 mL round-bottom flask. Add 6-methoxybenzothiazole (1.0 g, 6.05 mmol) and anhydrous Acetonitrile (20 mL).
- Cooling: Place the flask in an ice/salt bath ( $-5^{\circ}\text{C}$ ).
- Scavenger: Add finely powdered  
  
(1.0 g, ~2 equiv). Note: This prevents demethylation.<sup>[1]</sup>
- Addition: Dissolve N-Bromosuccinimide (NBS) (1.02 g, 0.95 equiv) in Acetonitrile (10 mL). Add this solution dropwise over 30 minutes via syringe pump or addition funnel.
- Monitoring: Stir at  $0^{\circ}\text{C}$  for 4 hours. Monitor by TLC (Hexane:EtOAc 8:2).<sup>[1]</sup> Look for the disappearance of starting material (  
  
) and appearance of product (  
  
).<sup>[1]</sup>
- Workup:
  - Quench with saturated  
  
(removes oxidative traces).<sup>[1]</sup>
  - Evaporate MeCN. Partition residue between EtOAc and Water.
  - Wash Organic layer with Brine, dry over  
  
.<sup>[1]</sup>

- Purification: Recrystallize from hot Ethanol.
  - Yield Expectation: 75-85%.
  - Purity: >98% (by HPLC).[1]

## Diagnostic Data Table

Impurity / Side Product	Mass Spec (m/z)	Origin	Prevention Strategy
Starting Material	165 (M+)	Incomplete Rxn	Check stoichiometry; ensure NBS quality (NBS degrades over time).
5-Bromo isomer	243/245 (1:[1]1)	Regio-error	Lower Temp; Switch solvent to MeCN.
5,7-Dibromo	321/323/325 (1:2:1)	Over-reaction	Use 0.95 eq NBS; High dilution.
6-Hydroxy (Phenol)	151 (M+)	Ether Cleavage	Add ; Avoid strong acids. [1]
N-Bromo salt	Unstable	Reversible binding	Quench with thiosulfate during workup.

## References

- BenchChem Technical Support. Controlling Regioselectivity in Electrophilic Substitution of Benzothiazoles. (Accessed 2024).[1][2][3] Provides general directing group logic for benzothiazole scaffolds.
- Arkat USA. Synthesis of 2-substituted-6-hydroxy and 6-methoxy benzothiazoles from 1,4-benzoquinone.[1][4] Arkivoc 2008 (ix) 250-258.[1] Details the synthesis of the core scaffold and potential demethylation issues.

- PubChem.7-Bromo-6-methyl-2-propan-2-yl-1,3-benzothiazole Data.[1][2] Compound Summary for CID 130063559.[2] Verifies the existence and stability of C7-brominated benzothiazoles.
- ResearchGate.Synthesis of Novel Methoxy Substituted Benzothiazole Derivatives. Discusses bromination protocols using bromine in glacial acetic acid and associated temperature controls.

### Need Custom Synthesis?

BenchChem offers custom synthesis for rare earth carbides and specific isotopic labeling.

Email: [info@benchchem.com](mailto:info@benchchem.com) or [Request Quote Online](#).

## Sources

- [1. researchgate.net \[researchgate.net\]](https://www.researchgate.net)
- [2. 7-Bromo-6-methyl-2-propan-2-yl-1,3-benzothiazole | C11H12BrNS | CID 130063559 - PubChem \[pubchem.ncbi.nlm.nih.gov\]](https://pubchem.ncbi.nlm.nih.gov/compound/7-Bromo-6-methyl-2-propan-2-yl-1,3-benzothiazole)
- [3. BJOC - Copper-promoted C5-selective bromination of 8-aminoquinoline amides with alkyl bromides \[beilstein-journals.org\]](https://beilstein-journals.org)
- [4. arkat-usa.org \[arkat-usa.org\]](https://www.arkat-usa.org)
- To cite this document: BenchChem. [Technical Support Center: Bromination of 6-Methoxybenzothiazole]. BenchChem, [2026]. [Online PDF]. Available at: [\[https://www.benchchem.com/product/b13661636/docs#technical-support-center-bromination-of-6-methoxybenzothiazole\]](https://www.benchchem.com/product/b13661636/docs#technical-support-center-bromination-of-6-methoxybenzothiazole)

---

### Disclaimer & Data Validity:

The information provided in this document is for Research Use Only (RUO) and is strictly not intended for diagnostic or therapeutic procedures. While BenchChem strives to provide accurate protocols, we make no warranties, express or implied, regarding the fitness of this product for every specific experimental setup.

**Technical Support:** The protocols provided are for reference purposes. Unsure if this reagent suits your experiment?

**Need Industrial/Bulk Grade?** [Request Custom Synthesis Quote](#)

## BenchChem

Our mission is to be the trusted global source of essential and advanced chemicals, empowering scientists and researchers to drive progress in science and industry.

### Contact

Address: 3281 E Guasti Rd  
Ontario, CA 91761, United States  
Phone: (601) 213-4426  
Email: [info@benchchem.com](mailto:info@benchchem.com)

[Contact our Ph.D. Support Team for a compatibility check](#)