

Comprehensive Structural Profiling of 2-Bromo-4-methoxybenzohydrazide[1]

Author: BenchChem Technical Support Team. **Date:** April 2026

Compound of Interest

Compound Name: 2-Bromo-4-methoxybenzohydrazide
Cat. No.: B13660674

[Get Quote](#)

Executive Summary

2-Bromo-4-methoxybenzohydrazide (CAS: 1375151-62-4) represents a critical scaffold in medicinal chemistry, serving as a versatile intermediate for the synthesis of Schiff bases, 1,3,4-oxadiazoles, and fused heterocyclic systems.[1] Its structural integrity is defined by the interplay between the electron-donating methoxy group and the sterically significant ortho-bromine atom.[1] This guide provides a rigorous technical analysis of its chemical structure, spectroscopic signature, and analytical validation protocols, designed to support high-fidelity drug development workflows.

Chemical Identity & Physicochemical Properties[2] [3][4][5][6]

Property	Data
IUPAC Name	2-Bromo-4-methoxybenzohydrazide
CAS Number	1375151-62-4
Molecular Formula	C ₈ H ₉ BrN ₂ O ₂
Molecular Weight	245.07 g/mol (79Br); 247.07 g/mol (81Br)
Monoisotopic Mass	243.9847 Da
Physical State	White to off-white crystalline solid
Solubility	Soluble in DMSO, DMF, Methanol (hot); Insoluble in water
Melting Point	Predicted:[1][2][3][4] 145–155 °C (Dependent on polymorph/purity)

Synthetic Pathway & Impurity Profiling

Understanding the synthesis is prerequisite to accurate structural analysis, as it dictates the impurity profile. The compound is typically synthesized via hydrazinolysis of Methyl 2-bromo-4-methoxybenzoate.[1]

Reaction Logic

The nucleophilic hydrazine attacks the ester carbonyl. The ortho-bromine atom exerts a steric influence, often requiring elevated temperatures or longer reaction times compared to unhindered benzoates.

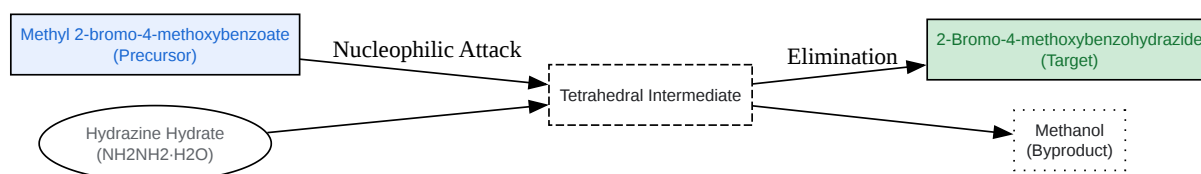

[Click to download full resolution via product page](#)

Caption: Nucleophilic acyl substitution pathway for the synthesis of the target hydrazide.

Critical Impurities:

- Unreacted Ester: Detectable via Methyl singlet at ~3.85 ppm (distinct from OMe, usually ~3.80 ppm).
- 2-Bromo-4-methoxybenzoic Acid: Hydrolysis byproduct; detectable via broad OH stretch (2500–3300 cm^{-1}) in IR.[1]
- Symmetrical Hydrazine: N,N'-di(2-bromo-4-methoxybenzoyl)hydrazine (dimer), formed if hydrazine stoichiometry is insufficient.[1]

Spectroscopic Elucidation (The Core)

Nuclear Magnetic Resonance (NMR)

The ^1H NMR spectrum in DMSO-d_6 is characterized by the distinct ortho-coupling of the aromatic ring and the labile hydrazide protons.

Predicted ^1H NMR Assignment (400 MHz, DMSO-d_6):

Position	Shift (δ ppm)	Multiplicity	Integration	Coupling (J Hz)	Structural Logic
-CONH-	9.30 – 9.50	Singlet (br)	1H	-	Amide proton; shift varies with concentration /H-bonding. [1]
H-6	7.35 – 7.45	Doublet	1H	$J \approx 8.5$	Ortho to carbonyl; shielded relative to ester due to hydrazide electron density.[1]
H-3	7.20 – 7.25	Doublet	1H	$J \approx 2.5$	Ortho to Br, meta to OMe.
H-5	6.95 – 7.05	dd	1H	$J \approx 8.5, 2.5$	Ortho to OMe (shielding effect); meta to Br.
-NH ₂	4.40 – 4.60	Singlet (br)	2H	-	Terminal amine; broadens due to exchange. [1]
-OCH ₃	3.75 – 3.85	Singlet	3H	-	Characteristic methoxy singlet.[1]

¹³C NMR Key Signals:

- C=O (Carbonyl): ~166 ppm.
- C-O (Methoxy attached): ~160 ppm.
- C-Br (Bromine attached): ~122 ppm (Distinctive upfield shift for ipso-C-Br).[1]

Mass Spectrometry (MS)

The mass spectrum provides the definitive confirmation of the halogen content.

- Isotope Pattern: The presence of one Bromine atom results in a characteristic 1:1 doublet for the molecular ion $[M]^+$ and $[M+2]^+$ at m/z 244 and 246.
- Fragmentation Pathway:
 - $[M]^+$ (244/246): Parent Ion.
 - $[M - NH_2NH]^+$ (213/215): Acylium ion formation (loss of 31 Da).
 - $[M - NH_2NH - CO]^+$ (185/187): Aryl cation.[1]

Infrared Spectroscopy (FT-IR)

Experimental validation requires identification of the hydrazide "fingerprint."

- N-H Stretch: Doublet or broad band at $3200\text{--}3350\text{ cm}^{-1}$ (Primary amine asymmetric/symmetric stretch).
- C=O Stretch (Amide I): $1650\text{--}1670\text{ cm}^{-1}$. Lower frequency than the ester precursor ($\sim 1720\text{ cm}^{-1}$) confirms conversion.
- C-O-C Stretch: Strong band at $\sim 1250\text{ cm}^{-1}$ (Aryl alkyl ether).

Analytical Protocols

Protocol A: High-Performance Liquid Chromatography (HPLC)

For purity assessment during drug development, a reverse-phase method is recommended.[1]

- Column: C18 (e.g., Agilent Zorbax Eclipse Plus), 4.6 x 100 mm, 3.5 μ m.
- Mobile Phase:
 - A: 0.1% Formic Acid in Water.
 - B: Acetonitrile.
- Gradient: 5% B to 95% B over 10 minutes.
- Detection: UV at 254 nm (aromatic) and 280 nm.
- Expected Retention: The hydrazide is more polar than the ester precursor and will elute earlier.

Protocol B: Sample Preparation for NMR

- Weighing: Accurately weigh 5–10 mg of the solid into a clean vial.
- Solvation: Add 0.6 mL of DMSO- d_6 (99.9% D). Chloroform- d is not recommended due to poor solubility of the hydrazide moiety.
- Filtration: If the solution is cloudy (indicating inorganic salts from synthesis), filter through a cotton plug into the NMR tube.
- Acquisition: Set relaxation delay (d_1) to >1.0s to ensure accurate integration of the aromatic protons vs. the methoxy protons.

Structural Validation Workflow

The following diagram illustrates the logical decision tree for validating the structure of **2-Bromo-4-methoxybenzohydrazide**.

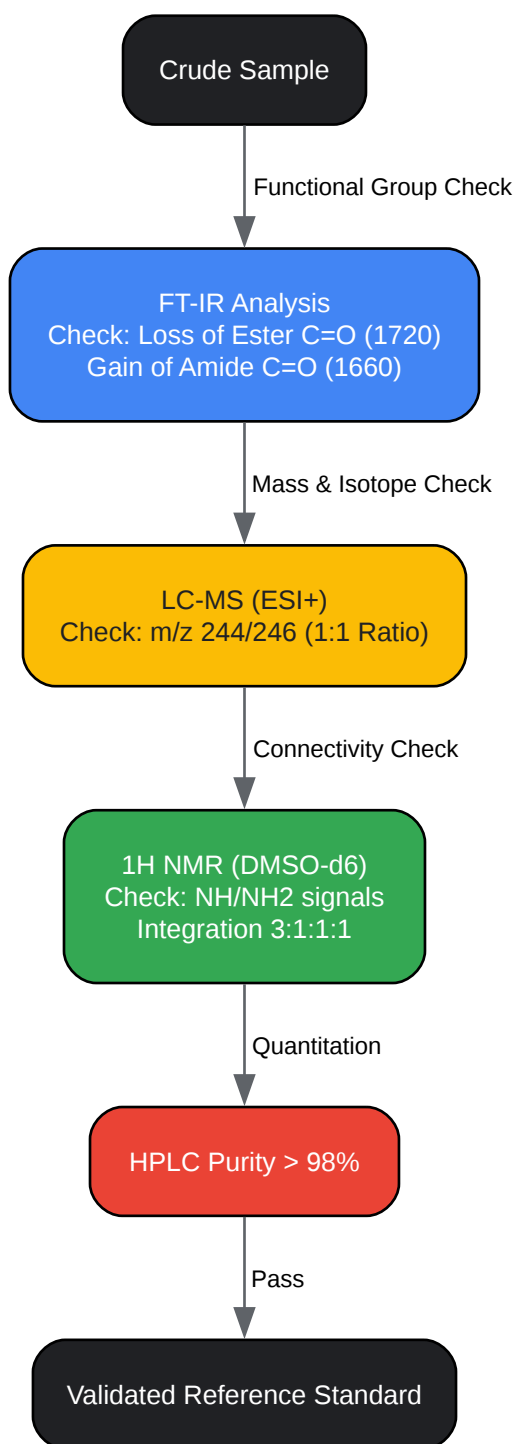

[Click to download full resolution via product page](#)

Caption: Step-by-step analytical workflow for structural validation of the target hydrazide.

References

- Synthesis of Hydrazides: Narang, R., et al. "Synthesis, characterization, and evaluation of the antimicrobial activity of some new hydrazide derivatives." Medicinal Chemistry Research, 2012. [Link](#)
- Precursor Characterization (Methyl 2-bromo-4-methoxybenzoate): BenchChem. "Technical Guide to the ¹H NMR Spectrum of Ethyl 2-Bromo-4-methoxybenzoate." BenchChem Technical Library, 2025. [Link](#)
- General Hydrazide Spectral Data: Silverstein, R. M., et al. Spectrometric Identification of Organic Compounds. 8th Ed., Wiley, 2014. (Standard Reference for IR/NMR shifts).
- Product Identity: PubChem Compound Summary for CID 1375151-62-4 (**2-Bromo-4-methoxybenzohydrazide**). [Link](#)
- Crystallographic Analogs: Fun, H. K., et al. "2,5-Bis(4-methoxyphenyl)-1,3,4-oxadiazole." [1] Acta Crystallographica Section E, 2010. (Describes structural features of the hydrazide-derived oxadiazole core). [Link](#)

Need Custom Synthesis?

BenchChem offers custom synthesis for rare earth carbides and specific isotopic labeling.

Email: info@benchchem.com or [Request Quote Online](#).

Sources

- 1. [353278-57-6|2-Bromo-4-methoxybenzamide|BLD Pharm \[bldpharm.com\]](#)
- 2. [pharmacyeducation.fip.org \[pharmacyeducation.fip.org\]](#)
- 3. [2-Bromo-4-methoxybenzaldehyde | C8H7BrO2 | CID 11127641 - PubChem \[pubchem.ncbi.nlm.nih.gov\]](#)
- 4. [Synthesis of 4-Methoxybenzoylhydrazones and Evaluation of Their Antiglycation Activity - PMC \[pmc.ncbi.nlm.nih.gov\]](#)
- To cite this document: BenchChem. [Comprehensive Structural Profiling of 2-Bromo-4-methoxybenzohydrazide[1]]. BenchChem, [2026]. [Online PDF]. Available at: [\[https://www.benchchem.com/product/b13660674/docs#comprehensive-structural-profiling-of-2-bromo-4-methoxybenzohydrazide-1\]](https://www.benchchem.com/product/b13660674/docs#comprehensive-structural-profiling-of-2-bromo-4-methoxybenzohydrazide-1)

Disclaimer & Data Validity:

The information provided in this document is for Research Use Only (RUO) and is strictly not intended for diagnostic or therapeutic procedures. While BenchChem strives to provide accurate protocols, we make no warranties, express or implied, regarding the fitness of this product for every specific experimental setup.

Technical Support: The protocols provided are for reference purposes. Unsure if this reagent suits your experiment?

Need Industrial/Bulk Grade? [Request Custom Synthesis Quote](#)

BenchChem

Our mission is to be the trusted global source of essential and advanced chemicals, empowering scientists and researchers to drive progress in science and industry.

Contact

Address: 3281 E Guasti Rd
Ontario, CA 91761, United States
Phone: (601) 213-4426
Email: info@benchchem.com

[Contact our Ph.D. Support Team for a compatibility check](#)