

Application Note: Synthesis of α -Hydroxy Acids (AHAs) via Dimethyl Methyltartronate

Author: BenchChem Technical Support Team. **Date:** April 2026

Compound of Interest

Compound Name: *Dimethyl 2-hydroxy-2-methylmalonate*

Cat. No.: *B13658576*

[Get Quote](#)

Executive Summary & Mechanistic Rationale

α -Hydroxy acids (AHAs) are indispensable pharmacophores in drug design and versatile building blocks in organic synthesis. This application note details the robust, two-phase synthesis of AHAs—specifically utilizing [1] (dimethyl methyltartronate) as a primary synthon to generate lactic acid derivatives.

As a Senior Application Scientist, it is critical to understand that this protocol is not merely a sequence of steps, but a thermodynamically driven cascade. The synthesis relies on two fundamental chemical transformations:

- **Base-Catalyzed Saponification:** The hydrolysis of the geminal dimethyl esters yields the corresponding dicarboxylate salt. The presence of the α -hydroxyl group increases the electrophilicity of the ester carbonyls, ensuring rapid saponification compared to standard unfunctionalized malonates.
- **Thermal Decarboxylation:** Upon acidification to methyltartronic acid, controlled thermal decomposition is initiated. The mechanism proceeds via an internal electronic redistribution through a cyclic six-membered transition state[2]. This concerted C–C bond cleavage

releases carbon dioxide gas, producing an enol intermediate that rapidly tautomerizes to the stable

-hydroxy monocarboxylic acid[2]. The activation energy for this transition state requires temperatures generally exceeding 130 °C[3].

Process Visualizations



[Click to download full resolution via product page](#)

Workflow for the synthesis of alpha-hydroxy acids from dimethyl methyltartronate.

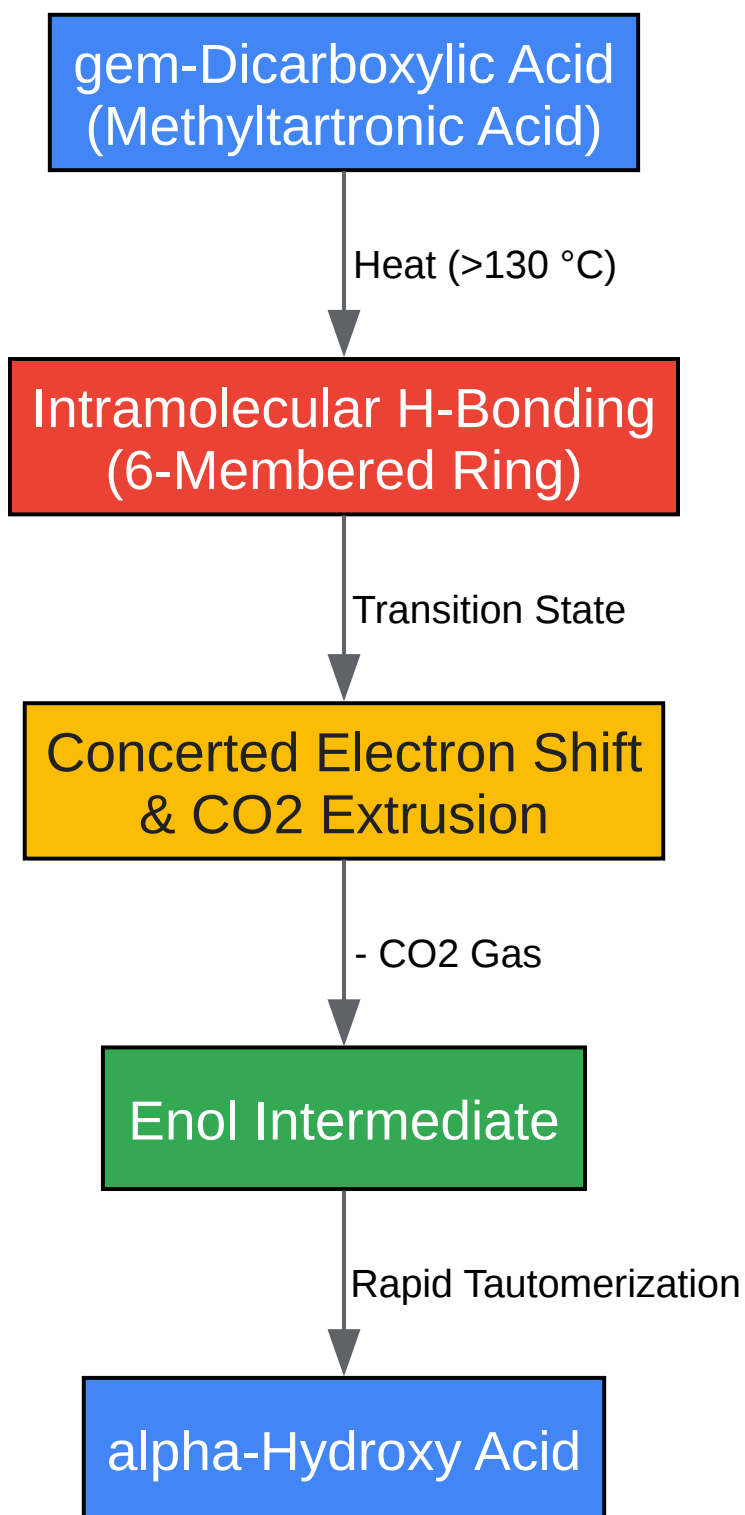

[Click to download full resolution via product page](#)

Mechanistic pathway of the thermal decarboxylation of methyltartronic acid.

Self-Validating Experimental Protocols

Phase 1: Saponification to Methyltartronic Acid

Causality Check: We utilize 2.5 equivalents of NaOH. The 0.5 eq excess ensures complete hydrolysis of both sterically hindered ester groups without requiring harsh, prolonged reflux that could trigger premature degradation.

- Initialization: Dissolve 10.0 mmol of Dimethyl methyltartronate in 15 mL of a 1:1 mixture of Ethanol/Milli-Q Water in a round-bottom flask.
- Base Addition: Cool the flask to 0 °C in an ice bath. Slowly add 25.0 mmol of NaOH (1.0 M aqueous solution) dropwise over 10 minutes to prevent exothermic spiking.
- Hydrolysis: Attach a reflux condenser and heat the mixture to 80 °C for 2 hours.
- Validation (TLC): Monitor the disappearance of the starting material via TLC (Hexane:EtOAc 7:3). The highly polar dicarboxylate salt will remain at the baseline.

Phase 2: Acidification & Isolation

Causality Check: The pKa values of malonic acid derivatives dictate that the pH must be driven below 2.0 to fully protonate the carboxylate salts into the uncharged dicarboxylic acid, enabling organic extraction.

- Acidification: Cool the reaction mixture to 0 °C. Slowly add 6M HCl dropwise until the pH reaches 1.0 (verify with pH paper).
- Extraction: Extract the aqueous layer with Ethyl Acetate (3 x 20 mL). The highly polar methyltartronic acid requires a polar aprotic extraction solvent.
- Purification: Wash the combined organic layers with brine, dry over anhydrous MgSO₄, filter, and concentrate under reduced pressure to yield crude methyltartronic acid as a white solid.

Phase 3: Thermal Decarboxylation

Causality Check: Decarboxylation is an entropically driven process. By monitoring the physical evolution of CO₂ gas, the protocol becomes self-validating. The reaction is strictly complete

when bubbling ceases.

- **Setup:** Transfer the crude methyltartronic acid to a dry, 2-neck round-bottom flask equipped with a reflux condenser and a gas bubbler attached to the outlet. Add 10 mL of anhydrous xylenes (b.p. ~140 °C) as the heating medium.
- **Thermal Cleavage:** Heat the mixture to 140 °C. Observe the bubbler; steady gas evolution () will commence as the cyclic transition state is breached[3].
- **Completion & Tautomerization:** Maintain heating for 1.5 hours or until gas evolution completely ceases. The enol intermediate rapidly tautomerizes to the final AHA (lactic acid) in situ[2].
- **Isolation:** Cool to room temperature, concentrate under vacuum to remove xylenes, and purify the resulting AHA via vacuum distillation or recrystallization depending on the target purity requirements.

Quantitative Data & Analytical Validation

To ensure rigorous quality control, the following table summarizes the expected operational parameters and the critical NMR markers required to validate the structural transformation.

Parameter	Phase 1 & 2: Saponification	Phase 3: Decarboxylation
Operating Temperature	0 °C 80 °C (Reflux)	140 °C - 150 °C
Reaction Time	2.0 Hours	1.5 Hours (until gas ceases)
Expected Yield	> 95% (Crude Intermediate)	85 - 90% (Isolated AHA)
Primary Physical Marker	Baseline retention on TLC	Evolution of gas
H NMR Validation Marker	Loss of -OCH singlet (~3.8 ppm)	Appearance of -CH quartet (~4.1 ppm) Splitting of -CH singlet into a doublet (~1.4 ppm)

Note on NMR Causality: The starting material (dimethyl methyltartronate) possesses a methyl singlet because the

-carbon lacks a proton. Upon decarboxylation and subsequent tautomerization, a proton is transferred to the

-carbon. This newly formed

-proton couples with the adjacent methyl group, splitting the methyl signal into a doublet and appearing itself as a distinct quartet. This splitting pattern is the definitive proof of a successful synthesis.

References

- PubChem Compound Summary for CID 119098069 Source: National Center for Biotechnology Information (NIH) URL:[[Link](#)]
- Loss of Carboxy Group as CO₂: Decarboxylation of Malonic Acid Derivatives Source: Journal of Visualized Experiments (JoVE) URL:[[Link](#)]

- Spectroscopy of Hydrothermal Reactions. 5. Decarboxylation Kinetics of Malonic Acid and Monosodium Malonate Source: The Journal of Physical Chemistry (ACS Publications) URL: [\[Link\]](#)

Need Custom Synthesis?

BenchChem offers custom synthesis for rare earth carbides and specific isotopic labeling.

Email: info@benchchem.com or [Request Quote Online](#).

Sources

- [1. Dimethyl 2-hydroxy-2-methylmalonate | C6H10O5 | CID 119098069 - PubChem](#) [pubchem.ncbi.nlm.nih.gov]
- [2. Video: Loss of Carboxy Group as CO2: Decarboxylation of Malonic Acid Derivatives](#) [jove.com]
- [3. pubs.acs.org](#) [pubs.acs.org]
- To cite this document: BenchChem. [Application Note: Synthesis of -Hydroxy Acids (AHAs) via Dimethyl Methyltartronate]. BenchChem, [2026]. [Online PDF]. Available at: [<https://www.benchchem.com/product/b13658576/docs#application-note-synthesis-of-hydroxy-acids-ahas-via-dimethyl-methyltartronate>]

Disclaimer & Data Validity:

The information provided in this document is for Research Use Only (RUO) and is strictly not intended for diagnostic or therapeutic procedures. While BenchChem strives to provide accurate protocols, we make no warranties, express or implied, regarding the fitness of this product for every specific experimental setup.

Technical Support: The protocols provided are for reference purposes. Unsure if this reagent suits your experiment?

Need Industrial/Bulk Grade? [Request Custom Synthesis Quote](#)

BenchChem

Our mission is to be the trusted global source of essential and advanced chemicals, empowering scientists and researchers to drive progress in science and industry.

Contact

Address: 3281 E Guasti Rd
Ontario, CA 91761, United States
Phone: (601) 213-4426
Email: info@benchchem.com

[Contact our Ph.D. Support Team for a compatibility check](#)