

# 1H NMR characterization of 7-Chlorothiazolo[4,5-c]pyridine

**Author:** BenchChem Technical Support Team. **Date:** May 2026

## Compound of Interest

Compound Name: 7-Chlorothiazolo[4,5-c]pyridine

Cat. No.: B13656114

[Get Quote](#)

## Executive Summary

This guide provides a definitive protocol for the structural validation of **7-Chlorothiazolo[4,5-c]pyridine**, a critical fused heterocyclic scaffold in kinase inhibitor discovery.<sup>[1][2]</sup> Unlike standard phenyl-based intermediates, this bicyclic system exhibits significant solvent-dependent chemical shift variability and regioisomeric ambiguity.<sup>[1][2]</sup>

This document moves beyond basic spectral assignment to address:

- **Regioisomeric Differentiation:** Distinguishing the 7-chloro isomer from the 4-chloro alternative using spin-spin coupling logic.<sup>[2]</sup>
- **Solvent Selection Strategy:** Why DMSO-  
is superior to CDCl  
for this specific lipophilic, nitrogen-rich scaffold.
- **Quantitative Acquisition:** Parameters to prevent integration errors caused by the long relaxation times (

) of isolated heteroaromatic protons.

## Structural Analysis & Proton Assignment

To interpret the NMR spectrum, we must first establish the IUPAC numbering and predicted magnetic environment of the protons.[1][2]

Compound: **7-Chlorothiazolo[4,5-c]pyridine** Formula: C

H

CIN

S MW: 170.62 g/mol [1][2]

### The Magnetic Environment

The molecule consists of a thiazole ring fused to a pyridine ring. The "c" fusion implies the pyridine nitrogen is located at position 5.

- H2 (Thiazole): Located between S and N. Highly deshielded due to the electronegativity of both heteroatoms. Typically the most downfield signal.
- H4 (Pyridine): Adjacent to the pyridine nitrogen (C5) and the bridgehead (C3a). Deshielded by the adjacent nitrogen (alpha-effect).[2]
- H6 (Pyridine): Adjacent to the pyridine nitrogen (C5) and the chlorine-bearing carbon (C7).[2]
- C7-Cl: The chlorine substitution at position 7 removes the proton that would normally couple with H6, eliminating the characteristic ortho-coupling (

Hz) seen in the parent scaffold.[1][2]

### Theoretical Chemical Shift Prediction ( $\delta$ ppm)

Proton	Position	Multiplicity	Predicted Shift (DMSO- )	Structural Diagnostic
H2	Thiazole	Singlet (s)	9.40 – 9.60	Most downfield; sharp singlet.[2]
H4	Pyridine	Singlet (s)	8.90 – 9.10	to Pyridine N; no vicinal neighbors. [1]
H6	Pyridine	Singlet (s)	8.40 – 8.60	to Pyridine N; shielded by Cl relative to H4? No, Cl is EWG, but position is less deshielded than H4 (bridgehead effect).[2]

\*Note: H4 and H6 may exhibit a small long-range cross-ring coupling (

Hz), often appearing as broadened singlets.[1][2]

## Comparative Analysis: The "Alternatives"

In drug development, "characterization" is rarely about identifying a pure compound in isolation—it is about ruling out impurities and isomers.[1][2]

### Alternative 1: Regioisomeric Differentiation (7-Cl vs. 4-Cl)

A common synthetic pitfall is the formation of the 4-chloro isomer.[2] <sup>1</sup>H NMR is the fastest tool to distinguish them without requiring X-ray crystallography.

- **7-Chlorothiazolo[4,5-c]pyridine** (Target):

- Pattern: Three Singlets (H2, H4, H6).
- Reasoning: H4 and H6 are separated by the Nitrogen.[2] No vicinal protons exist.
- 4-Chlorothiazolo[4,5-c]pyridine (Alternative):
  - Pattern: One Singlet (H2) + Two Doublets (H6, H7).
  - Reasoning: If Cl is at position 4, protons H6 and H7 remain.[1][2] They are vicinal (adjacent) and will show a strong ortho-coupling ( Hz).[2]

Decision Logic:

“

*If you see doublets in the aromatic region, your synthesis failed to selectively chlorinate position 7.*

## Alternative 2: Solvent Selection (DMSO- vs. CDCl )

While CDCl

is the standard "first-pass" solvent, it is suboptimal for this scaffold.[1][2]

Feature	DMSO- (Recommended)	CDCl (Alternative)
Solubility	Excellent. Dissolves the planar, -stacking heteroaromatic system effectively.[2]	Poor. Risk of aggregation, leading to broad peaks and non-quantitative integration.[1][2]
Peak Separation	High. Polar interaction with H2 prevents overlap with H4/H6.	Variable. H2 often shifts upfield, potentially overlapping with H4.[1][2]
Water Peak	~3.33 ppm (Usually clear of aromatic region).	~1.56 ppm (Clear).[1]
Exchangeable Protons	Visible (if any precursors remain).	Often invisible/broad.

## Experimental Protocol

### Sample Preparation

- Mass: Weigh 5.0 – 8.0 mg of the solid product.
- Solvent: Add 0.6 mL of DMSO- (99.9% D).
  - Tip: Use an ampoule to ensure dryness; water in DMSO can broaden the H2 thiazole signal via H-bonding exchange.[2]
- Homogenization: Sonicate for 30 seconds. Ensure the solution is perfectly clear. Turbidity indicates undissolved solids which will distort integration.

### Acquisition Parameters (Bruker/Varian Standard)

To ensure the integrals are accurate (essential for purity calculation), you must account for the long

relaxation times of the isolated protons.

- Pulse Sequence:zg30 (30° pulse) or zg (90° pulse with long delay).
- Spectral Width (SW): 14 ppm (-2 to 12 ppm).
- Acquisition Time (AQ): 3.0 – 4.0 seconds.[1]
- Relaxation Delay (D1):Wait at least 10 seconds.
  - Why? Isolated aromatic protons (like H2 and H4) have inefficient relaxation pathways. A standard D1 of 1.0s will saturate these signals, reducing their integral intensity by 10-20% and leading to false impurity calculations.[1][2]
- Scans (NS): 16 or 32 (Sufficient for >95% purity).
- Temperature: 298 K (25°C).[1]

## Visualizations

### Workflow: Structural Elucidation Pipeline

This diagram outlines the logical flow from crude synthesis to final structural confirmation, highlighting the "Go/No-Go" decision points based on NMR data.

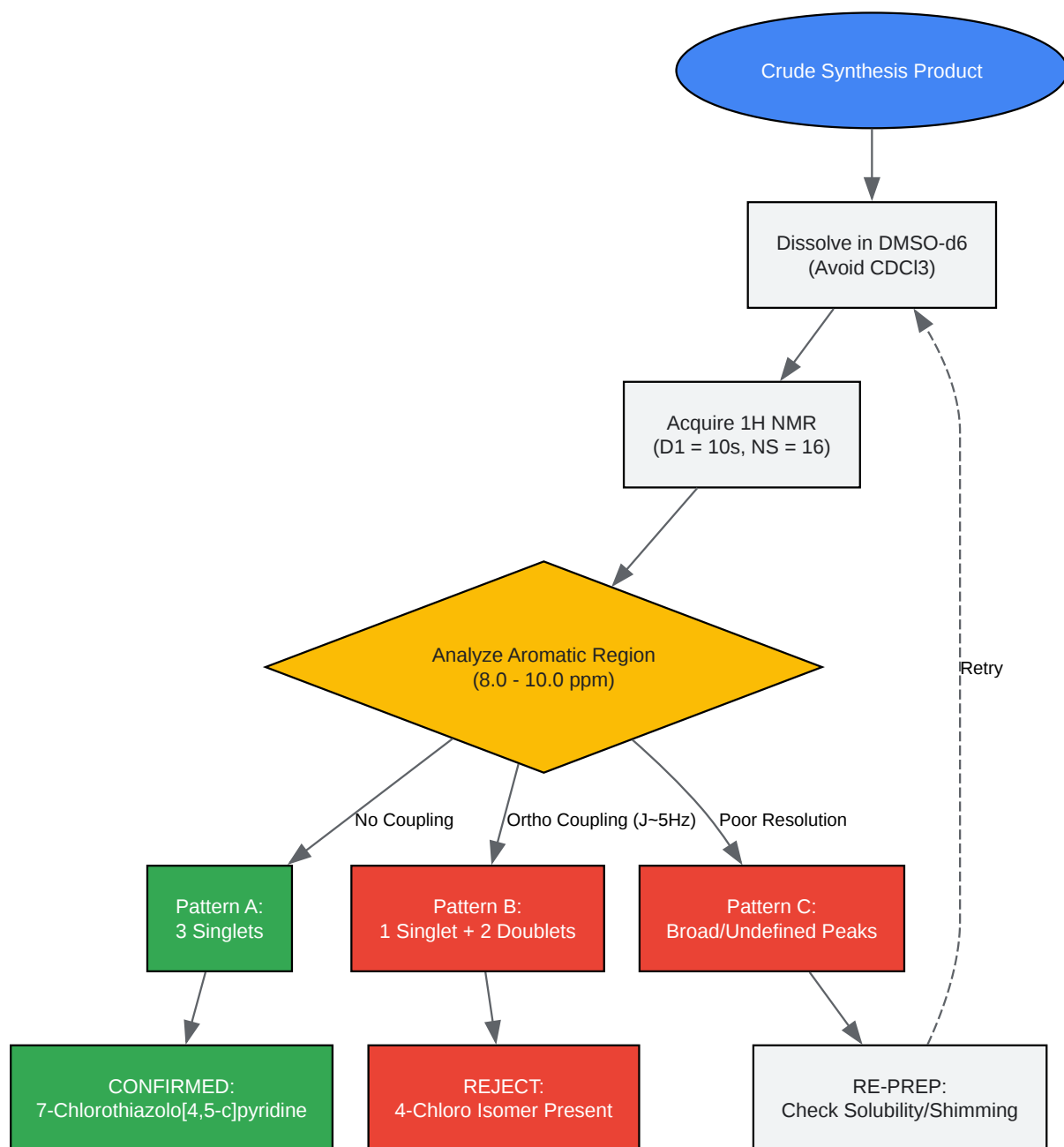

[Click to download full resolution via product page](#)

Caption: Decision logic for confirming the 7-chloro regioisomer based on spin-spin coupling patterns.

## Comparison: Solvent Effect Mechanism

A visual representation of why DMSO is the superior choice for this specific scaffold.

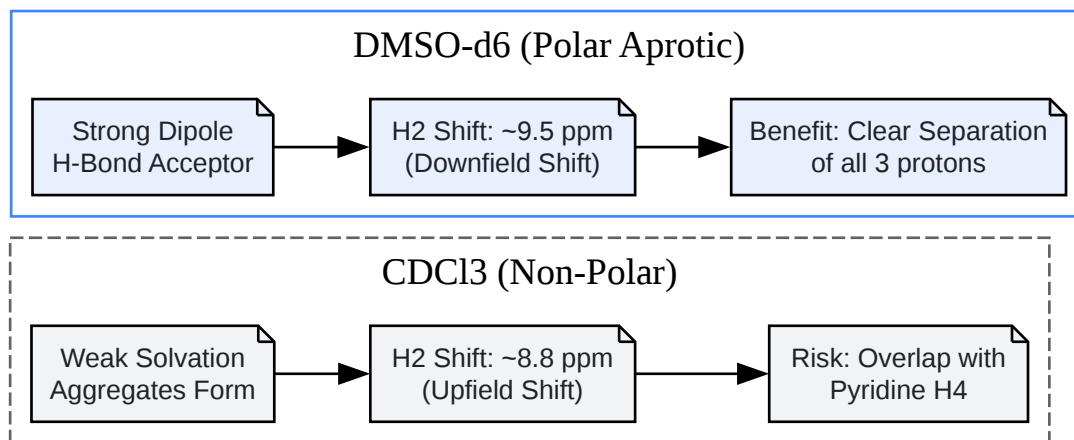

[Click to download full resolution via product page](#)

Caption: Impact of solvent polarity on the chemical shift of the acidic Thiazole H2 proton.[2]

## References

- PubChem.Thiazolo[4,5-c]pyridine | C6H4N2S.[1][3] National Library of Medicine. Available at: [\[Link\]](#)
- Silverstein, R. M., Webster, F. X., & Kiemle, D. J.Spectrometric Identification of Organic Compounds. (Standard text for solvent effects and coupling constants).
- Reich, H. J.Bordwell pKa Table (Acidity in DMSO). University of Wisconsin-Madison.[2] (Reference for acidity of thiazole C2-H). Available at: [\[Link\]](#)[1]

### Need Custom Synthesis?

BenchChem offers custom synthesis for rare earth carbides and specific isotopic labeling.

Email: [info@benchchem.com](mailto:info@benchchem.com) or [Request Quote Online](#).

## Sources

- [1. mdpi.com \[mdpi.com\]](#)
- [2. researchgate.net \[researchgate.net\]](#)
- [3. Thiazolo\[4,5-c\]pyridine | C6H4N2S | CID 585837 - PubChem \[pubchem.ncbi.nlm.nih.gov\]](#)
- To cite this document: BenchChem. [1H NMR characterization of 7-Chlorothiazolo[4,5-c]pyridine]. BenchChem, [2026]. [Online PDF]. Available at: [\[https://www.benchchem.com/product/b13656114/docs#1h-nmr-characterization-of-7-chlorothiazolo-4-5-c-pyridine\]](https://www.benchchem.com/product/b13656114/docs#1h-nmr-characterization-of-7-chlorothiazolo-4-5-c-pyridine)

---

### Disclaimer & Data Validity:

The information provided in this document is for Research Use Only (RUO) and is strictly not intended for diagnostic or therapeutic procedures. While BenchChem strives to provide accurate protocols, we make no warranties, express or implied, regarding the fitness of this product for every specific experimental setup.

**Technical Support:** The protocols provided are for reference purposes. Unsure if this reagent suits your experiment?

**Need Industrial/Bulk Grade?** [Request Custom Synthesis Quote](#)

## BenchChem

Our mission is to be the trusted global source of essential and advanced chemicals, empowering scientists and researchers to drive progress in science and industry.

### Contact

Address: 3281 E Guasti Rd  
Ontario, CA 91761, United States  
Phone: (601) 213-4426  
Email: [info@benchchem.com](mailto:info@benchchem.com)

[Contact our Ph.D. Support Team for a compatibility check](#)

