

Technical Support Center: Optimizing GLP-1 (7-37) Acetate Cell-Based Assays

Author: BenchChem Technical Support Team. **Date:** May 2026

Compound of Interest

Compound Name: GLP-1 (7-37) acetate

Cat. No.: B13654919

[Get Quote](#)

This guide provides researchers, scientists, and drug development professionals with essential information for optimizing incubation times and troubleshooting cell-based assays involving **GLP-1 (7-37) acetate**.

Frequently Asked Questions (FAQs)

Q1: What is the primary signaling pathway activated by **GLP-1 (7-37) acetate**?

A1: **GLP-1 (7-37) acetate** primarily signals through the GLP-1 receptor (GLP-1R), a G-protein-coupled receptor (GPCR).[1][2] Upon binding, the receptor predominantly couples to the G α s protein, which activates adenylyl cyclase to increase intracellular cyclic AMP (cAMP) levels.[1][3][4][5] This increase in cAMP activates downstream effectors like Protein Kinase A (PKA) and Exchange Protein Activated by cAMP (EPAC) to mediate various cellular responses, most notably glucose-dependent insulin secretion in pancreatic β -cells.[1][3][5][6]

Q2: Are there other signaling pathways involved?

A2: Yes, besides the canonical G α s/cAMP pathway, the GLP-1R can also couple to other G proteins like G α q, leading to the mobilization of intracellular calcium.[1][5] Additionally, GLP-1R activation can stimulate non-G protein-mediated pathways, such as those involving β -arrestin,

which can lead to the phosphorylation of extracellular signal-regulated kinases (ERK1/2).[1][6]
[7]

Q3: What are the most common cell-based assays for studying GLP-1 (7-37) activity?

A3: The most common assays focus on key downstream signaling events. These include:

- **cAMP Accumulation Assays:** These are the most direct measure of GLP-1R activation and can be performed using various methods like HTRF (Homogeneous Time-Resolved Fluorescence), FRET, ELISA, and bioluminescent reporters (e.g., GloSensor™).[8][9]
- **ERK1/2 Phosphorylation Assays:** Typically measured via Western blotting or specific ELISA kits, these assays assess an alternative signaling branch.[10][11]
- **Calcium Mobilization Assays:** These assays use fluorescent dyes to measure changes in intracellular calcium, often downstream of Gαq activation.[12]
- **Reporter Gene Assays:** These assays utilize a reporter gene (e.g., luciferase) under the control of a cAMP response element (CRE) to measure transcriptional activation downstream of cAMP signaling.[13]

Q4: How long should I incubate my cells with **GLP-1 (7-37) acetate**?

A4: The optimal incubation time is highly dependent on the specific assay and the signaling event being measured.

- For cAMP accumulation, incubation times are generally short, ranging from 30 minutes to 1 hour.[8][14][15] Some protocols may extend this up to 5 hours.[13]
- For ERK1/2 phosphorylation, the response is typically rapid and transient, with maximal phosphorylation occurring within 10 to 20 minutes of stimulation.[7][16]
- For reporter gene assays, a longer incubation period of 6 to 24 hours is often required to allow for transcription and translation of the reporter protein.[3][17][18]

Troubleshooting Guide

Issue	Possible Cause(s)	Recommended Solution(s)
No or Low Signal	Peptide Degradation: GLP-1 is susceptible to degradation by enzymes like dipeptidyl peptidase-IV (DPP-IV), which may be present in serum or secreted by cells.[10][19][20]	Prepare fresh peptide solutions for each experiment. Avoid repeated freeze-thaw cycles. Consider using a DPP-IV inhibitor in your assay buffer if degradation is suspected.
Cell Health/Passage Number: Cells that are unhealthy, have a high passage number, or are overly confluent may exhibit reduced receptor expression and signaling capacity.[10]	Use cells with a consistent and low passage number. Ensure cells are healthy and seeded at an appropriate density (typically 80-90% confluency). [10]	
Incorrect Incubation Time: The incubation time may be too short or too long for the specific signaling event being measured.	Refer to the recommended incubation times for your specific assay. Perform a time-course experiment to determine the optimal incubation period for your cell system.	
High Variability Between Replicates	Inconsistent Cell Seeding: Uneven cell distribution across wells leads to variability in the response.	Ensure a homogenous cell suspension before and during plating. Mix gently between pipetting.
Assay Conditions: Fluctuations in temperature, incubation times, or reagent concentrations can introduce variability.[10]	Standardize all assay steps. Ensure reagents are properly equilibrated to the required temperature before use. Use precise pipetting techniques.	
Edge Effects: Wells on the outer edges of the plate are more prone to evaporation and temperature changes, which	Avoid using the outer wells of the plate for experimental samples. Fill them with sterile PBS or media to maintain humidity.	

can affect cell growth and response.

Unexpected Dose-Response Curve

Peptide Concentration Issues:
Errors in serial dilutions or incorrect stock concentration can shift the EC50 value.

Carefully prepare serial dilutions from a freshly prepared stock solution. Confirm the concentration of the stock peptide if possible.

Receptor Desensitization: Prolonged exposure to high concentrations of agonist can lead to receptor internalization and desensitization, resulting in a bell-shaped dose-response curve.[1]

Shorten the incubation time. Perform a time-course experiment to identify a window where the response is maximal before desensitization occurs.

Biased Agonism: The peptide may preferentially activate one signaling pathway over another, leading to different potencies depending on the assay used.[10]

Test the compound in multiple assay formats (e.g., cAMP and ERK phosphorylation) to fully characterize its signaling profile.

Experimental Protocols & Data

Protocol 1: cAMP Accumulation Assay (HTRF)

This protocol is a competitive immunoassay where endogenous cAMP produced by the cells competes with a labeled cAMP tracer.[8]

Materials:

- HEK293 cells stably expressing the human GLP-1 receptor (HEK-GLP-1R).
- Assay Buffer: HBSS with 20 mM HEPES, 0.1% BSA, and 500 μ M IBMX (a phosphodiesterase inhibitor).
- **GLP-1 (7-37) Acetate Stock Solution.**

- HTRF cAMP Assay Kit (e.g., from Cisbio or PerkinElmer).
- White, low-volume 384-well plates.

Procedure:

- Cell Preparation: Seed HEK-GLP-1R cells into a 384-well plate at a density of 5,000-10,000 cells/well and culture overnight.
- Compound Preparation: Prepare serial dilutions of **GLP-1 (7-37) acetate** in assay buffer.
- Stimulation: Remove culture medium from the cells. Add 5 μ L of assay buffer (vehicle) or the corresponding GLP-1 (7-37) dilution to each well.
- Incubation: Incubate the plate for 30 minutes at room temperature.[\[8\]](#)[\[14\]](#)
- Detection: Add the HTRF detection reagents (cAMP-d2 and anti-cAMP cryptate) according to the manufacturer's instructions.
- Final Incubation: Incubate for 60 minutes at room temperature, protected from light.[\[8\]](#)
- Read Plate: Measure the fluorescence at 620 nm and 665 nm on an HTRF-compatible plate reader. The signal is inversely proportional to the amount of cAMP produced.

Protocol 2: ERK1/2 Phosphorylation Assay (Western Blot)

This protocol measures the increase in phosphorylated ERK1/2 relative to total ERK1/2.

Materials:

- MIN6 cells or other GLP-1R expressing cell line.
- Serum-free culture medium.
- **GLP-1 (7-37) Acetate** Stock Solution.
- Lysis Buffer (e.g., RIPA buffer with protease and phosphatase inhibitors).

- Primary Antibodies: Rabbit anti-phospho-ERK1/2 and Rabbit anti-total-ERK1/2.
- Secondary Antibody: HRP-conjugated anti-rabbit IgG.
- ECL substrate.

Procedure:

- Cell Preparation: Plate cells and grow to 80-90% confluency. Serum-starve the cells for 4-6 hours prior to the experiment.
- Stimulation: Treat cells with various concentrations of **GLP-1 (7-37) acetate** for different time points (e.g., 0, 2, 5, 10, 20, 30 minutes). A time course is critical to capture the peak response.
- Lysis: Terminate the stimulation by aspirating the medium and adding ice-cold lysis buffer.
- Protein Quantification: Determine the protein concentration of each lysate using a BCA or Bradford assay.
- Western Blotting:
 - Separate equal amounts of protein (20-30 µg) by SDS-PAGE and transfer to a PVDF membrane.
 - Block the membrane with 5% BSA or non-fat milk in TBST for 1 hour.
 - Incubate with the primary anti-phospho-ERK1/2 antibody overnight at 4°C.
 - Wash and incubate with the HRP-conjugated secondary antibody for 1 hour at room temperature.
 - Detect the signal using an ECL substrate.[\[10\]](#)
- Re-probing: Strip the membrane and re-probe with the anti-total-ERK1/2 antibody to normalize for protein loading.[\[10\]](#)

- Analysis: Quantify band intensities using densitometry and express the results as the ratio of phospho-ERK to total ERK.

Summary of Recommended Incubation Times

Assay Type	Signaling Readout	Typical Incubation Time	Key Considerations
cAMP Accumulation	cAMP Level	30 - 60 minutes	Short incubation is sufficient to capture peak cAMP levels. Use of a phosphodiesterase inhibitor (e.g., IBMX) is recommended to prevent cAMP degradation.
ERK1/2 Phosphorylation	p-ERK/Total ERK Ratio	5 - 20 minutes	The signal is rapid and transient. A time-course experiment is essential to identify the optimal time point.
Calcium Mobilization	Intracellular Ca ²⁺	1 - 2 minutes	The response is very rapid, occurring within seconds to a few minutes. Requires a reader with kinetic read capabilities (e.g., FLIPR).
Reporter Gene Assay	Luciferase/ β -gal Activity	6 - 24 hours	Requires sufficient time for gene transcription and translation of the reporter protein.

Visualizations

GLP-1R Signaling Pathways

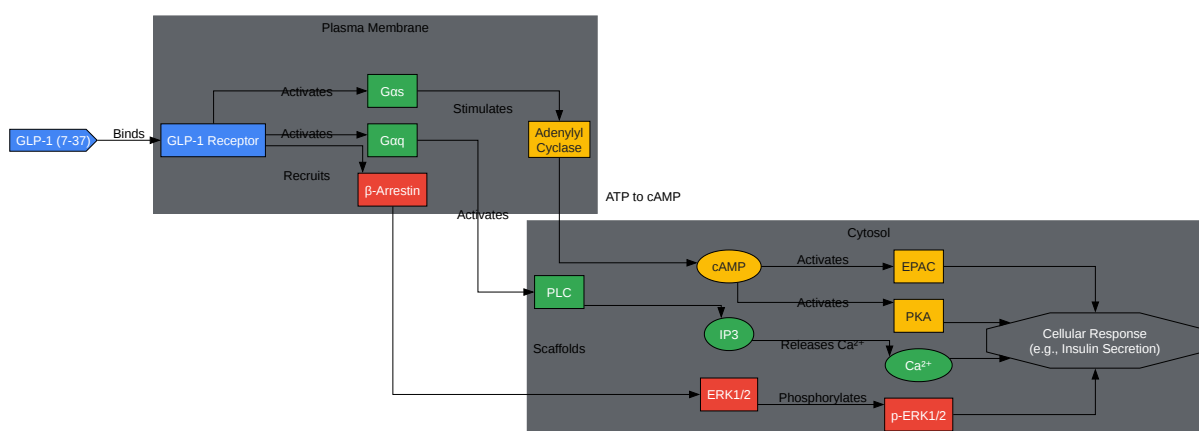

[Click to download full resolution via product page](#)

Caption: Overview of major GLP-1 Receptor signaling pathways.

Experimental Workflow for Optimizing Incubation Time

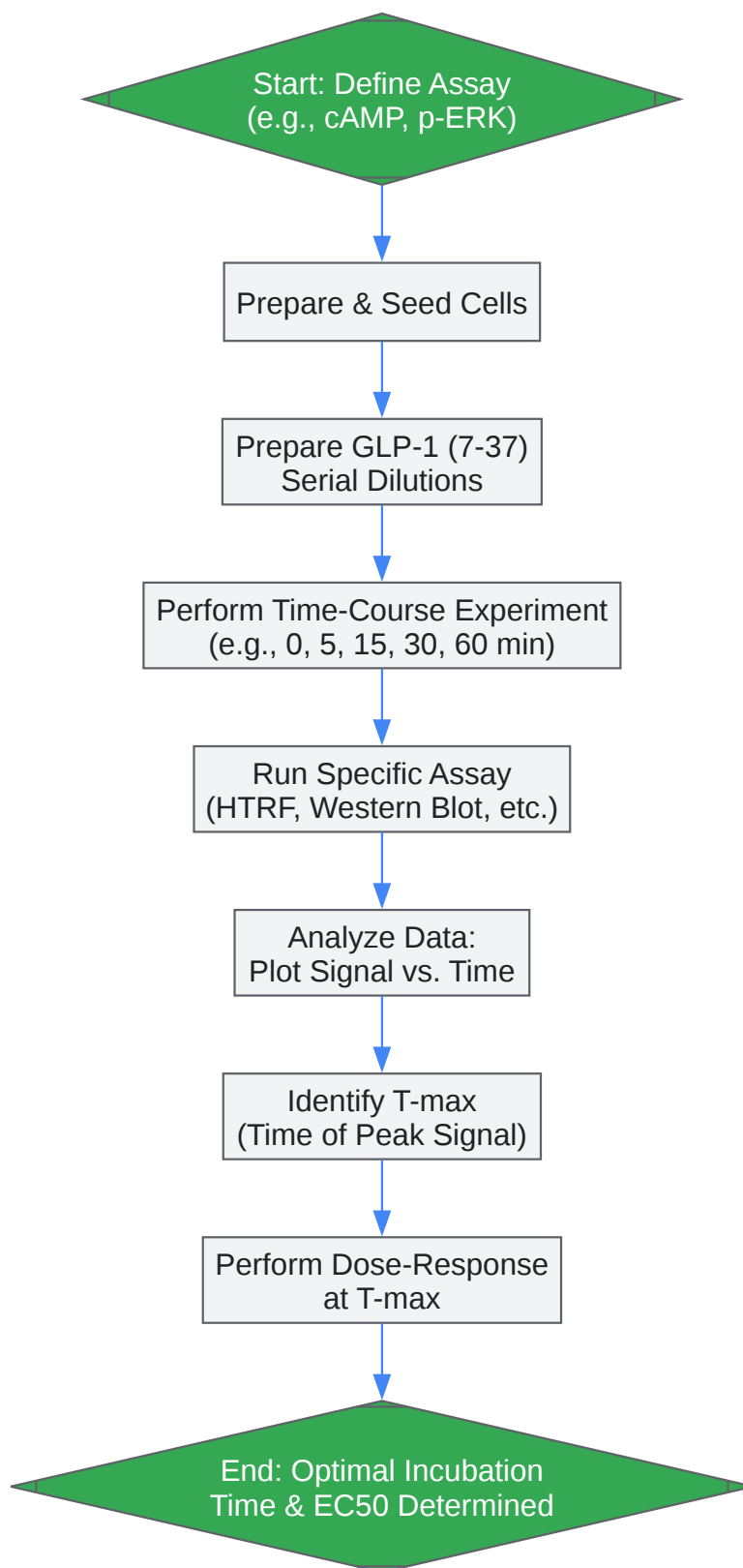

[Click to download full resolution via product page](#)

Caption: Logical workflow for determining optimal incubation time.

Need Custom Synthesis?

BenchChem offers custom synthesis for rare earth carbides and specific isotopic labeling.

Email: info@benchchem.com or [Request Quote Online](#).

References

- [1. mdpi.com \[mdpi.com\]](#)
- [2. GLP-1 signaling and the regulation of pancreatic \$\beta\$ -cells mass/function | Avances en Diabetología \[elsevier.es\]](#)
- [3. indigobiosciences.com \[indigobiosciences.com\]](#)
- [4. innoprot.com \[innoprot.com\]](#)
- [5. GLP-1: Molecular mechanisms and outcomes of a complex signaling system - PMC \[pmc.ncbi.nlm.nih.gov\]](#)
- [6. portlandpress.com \[portlandpress.com\]](#)
- [7. GLP-1 Mediates Antiapoptotic Effect by Phosphorylating Bad through a \$\beta\$ -Arrestin 1-mediated ERK1/2 Activation in Pancreatic \$\beta\$ -Cells - PMC \[pmc.ncbi.nlm.nih.gov\]](#)
- [8. benchchem.com \[benchchem.com\]](#)
- [9. diabetesjournals.org \[diabetesjournals.org\]](#)
- [10. benchchem.com \[benchchem.com\]](#)
- [11. researchgate.net \[researchgate.net\]](#)
- [12. Novel Small Molecule Glucagon-Like Peptide-1 Receptor Agonist S6 Stimulates Insulin Secretion From Rat Islets - PMC \[pmc.ncbi.nlm.nih.gov\]](#)
- [13. bpsbioscience.com \[bpsbioscience.com\]](#)
- [14. Establishing a Relationship between In Vitro Potency in Cell-Based Assays and Clinical Efficacious Concentrations for Approved GLP-1 Receptor Agonists - PMC \[pmc.ncbi.nlm.nih.gov\]](#)
- [15. jme.bioscientifica.com \[jme.bioscientifica.com\]](#)
- [16. researchgate.net \[researchgate.net\]](#)
- [17. indigobiosciences.com \[indigobiosciences.com\]](#)
- [18. cdn.caymanchem.com \[cdn.caymanchem.com\]](#)

- [19. researchgate.net \[researchgate.net\]](#)
- [20. alpc.com \[alpc.com\]](#)
- To cite this document: BenchChem. [Technical Support Center: Optimizing GLP-1 (7-37) Acetate Cell-Based Assays]. BenchChem, [2026]. [Online PDF]. Available at: [<https://www.benchchem.com/product/b13654919/docs#technical-support-center-optimizing-glp-1-7-37-acetate-cell-based-assays>]

Disclaimer & Data Validity:

The information provided in this document is for Research Use Only (RUO) and is strictly not intended for diagnostic or therapeutic procedures. While BenchChem strives to provide accurate protocols, we make no warranties, express or implied, regarding the fitness of this product for every specific experimental setup.

Technical Support: The protocols provided are for reference purposes. Unsure if this reagent suits your experiment?

Need Industrial/Bulk Grade? [Request Custom Synthesis Quote](#)

BenchChem

Our mission is to be the trusted global source of essential and advanced chemicals, empowering scientists and researchers to drive progress in science and industry.

Contact

Address: 3281 E Guasti Rd
Ontario, CA 91761, United States
Phone: (601) 213-4426
Email: info@benchchem.com

[Contact our Ph.D. Support Team for a compatibility check](#)