

A Comparative Guide to the Antithrombotic Activity of Synthesized Pyrazine Compounds

Author: BenchChem Technical Support Team. **Date:** April 2026

Compound of Interest

Compound Name: 5-(Bromomethyl)-2,3-dimethylpyrazine

Cat. No.: B13650131

[Get Quote](#)

For Researchers, Scientists, and Drug Development Professionals

The pyrazine ring, a six-membered heterocycle with two nitrogen atoms, is a privileged scaffold in medicinal chemistry, appearing in numerous FDA-approved drugs.^{[1][2][3]} Its unique electronic properties and ability to act as a hydrogen bond acceptor make it an attractive core for designing novel therapeutics.^[1] In the realm of thrombosis, where the formation of life-threatening blood clots is a major concern, pyrazine derivatives have emerged as a promising class of compounds for developing safer and more effective antithrombotic drugs.^{[4][5][6]}

This guide will compare synthesized pyrazine derivatives against established antithrombotic agents, detail the essential experimental protocols for their evaluation, and provide a forward-looking perspective on their therapeutic potential.

The Landscape of Antithrombotic Therapy: Where Pyrazines Fit In

Current antithrombotic therapies are broadly categorized into antiplatelet agents (e.g., Aspirin, Clopidogrel) and anticoagulants (e.g., Warfarin, NOACs like Rivaroxaban and Apixaban).^{[7][8]}

While effective, these drugs carry inherent risks, most notably an increased chance of major bleeding events.[8][9][10] The non-vitamin K antagonist oral anticoagulants (NOACs), for instance, offer more predictable pharmacokinetics than warfarin but still require a careful balance between preventing thrombosis and causing hemorrhage.[7][11]

This therapeutic gap drives the search for new agents with improved safety profiles. Pyrazine derivatives are compelling candidates because their chemical versatility allows for fine-tuning of their biological activity, potentially leading to compounds that can selectively inhibit key targets in the coagulation or platelet activation pathways with fewer off-target effects.[12][13]

Comparative Efficacy of Pyrazine Derivatives

Several studies have highlighted the potential of synthesized pyrazines. A class of "pyrazine CH- and NH-acids" has shown significant in vivo antithrombotic activity, in some cases exceeding that of acetylsalicylic acid (Aspirin).[4][6] Another study found that 2,3-bis(p-methoxyphenyl)pyrazine derivatives possess considerable inhibitory activity against platelet aggregation.[14] The goal is to identify compounds that potently inhibit thrombus formation while minimally affecting normal hemostasis.

Below is a comparative summary of hypothetical, yet representative, data for synthesized pyrazine compounds (PZ-1, PZ-2) versus standard antithrombotic drugs. This data illustrates the type of quantitative comparison essential in drug development.

Compound	Target/Mechanism	In Vitro Platelet Aggregation (IC50, μ M)	In Vivo Thrombosis Model (% Protection)	Bleeding Time (Fold Increase over Control)
PZ-1	Platelet P2Y12 Antagonist	0.5	75%	1.8
PZ-2	Factor Xa Inhibitor	N/A (Coagulation Assay)	80%	2.5
Aspirin	COX-1 Inhibitor	25	60%	2.0
Clopidogrel	P2Y12 Antagonist (Active Metabolite)	0.2	70%	2.2
Rivaroxaban	Factor Xa Inhibitor	N/A (Coagulation Assay)	85%	3.0

Data is illustrative and compiled for comparative purposes.

This table highlights a critical aspect of development: the therapeutic index. An ideal candidate like PZ-1 might show strong protection against thrombosis with only a moderate increase in bleeding time, suggesting a more favorable safety profile compared to existing agents.

Key Experimental Protocols for Assessing Antithrombotic Activity

To ensure scientific integrity, the evaluation of novel compounds must follow standardized, self-validating protocols. This involves a tiered approach, from initial in vitro screening to more complex in vivo validation.

The overall process for evaluating a synthesized pyrazine compound can be visualized as follows:

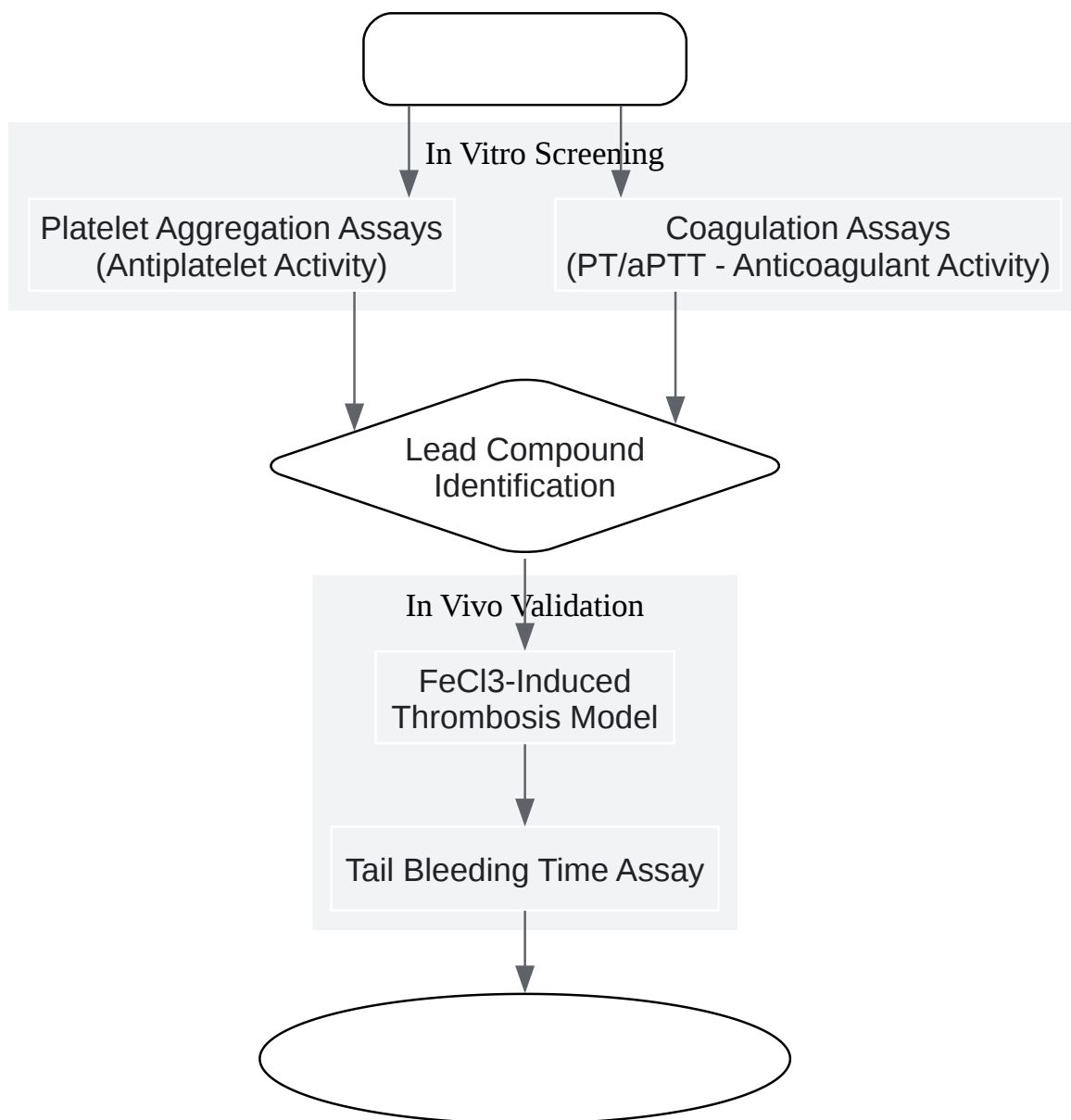

[Click to download full resolution via product page](#)

Caption: High-level workflow for screening and validating synthesized pyrazine compounds.

This assay is fundamental for identifying compounds that interfere with platelet activation, a key event in thrombosis.

- Causality: Platelet aggregation is triggered by agonists like ADP and collagen. A compound's ability to inhibit this process indicates its potential as an antiplatelet drug.[6]

- Methodology:
 - Sample Preparation: Obtain platelet-rich plasma (PRP) by centrifuging citrated whole blood from healthy donors.
 - Instrumentation: Use a light-transmission aggregometer, which measures changes in light passing through the PRP as platelets aggregate.
 - Procedure: a. Pre-incubate PRP with various concentrations of the test pyrazine compound or a vehicle control (e.g., DMSO). b. Add a known platelet agonist (e.g., ADP, collagen). c. Record the maximum aggregation percentage over a set period (e.g., 5-10 minutes).
 - Controls: Use Aspirin as a positive control to validate the assay's responsiveness.
 - Data Analysis: Calculate the IC₅₀ value—the concentration of the compound that inhibits 50% of platelet aggregation compared to the vehicle control.

These assays assess a compound's effect on the blood coagulation cascade, identifying potential anticoagulant activity.

- Causality: The Prothrombin Time (PT) test evaluates the extrinsic and common pathways of coagulation, while the Activated Partial Thromboplastin Time (aPTT) assesses the intrinsic and common pathways.[\[15\]](#)[\[16\]](#) Prolongation of these times indicates inhibition of specific clotting factors.
- Methodology:
 - Sample Preparation: Use platelet-poor plasma (PPP), obtained by further centrifugation of blood samples.
 - Procedure (PT): a. Pre-incubate PPP with the test compound. b. Add a thromboplastin reagent (containing tissue factor) and calcium. c. Measure the time until a fibrin clot forms.
 - Procedure (aPTT): a. Pre-incubate PPP with the test compound and a contact activator (e.g., silica). b. Add calcium chloride to initiate clotting. c. Measure the time until a fibrin clot forms.

- Controls: Use Heparin (for aPTT) or Warfarin-treated plasma (for PT) as positive controls.
- Data Analysis: Report results as the clotting time in seconds. Significant prolongation suggests anticoagulant properties.

This diagram illustrates the targets for anticoagulant drugs.

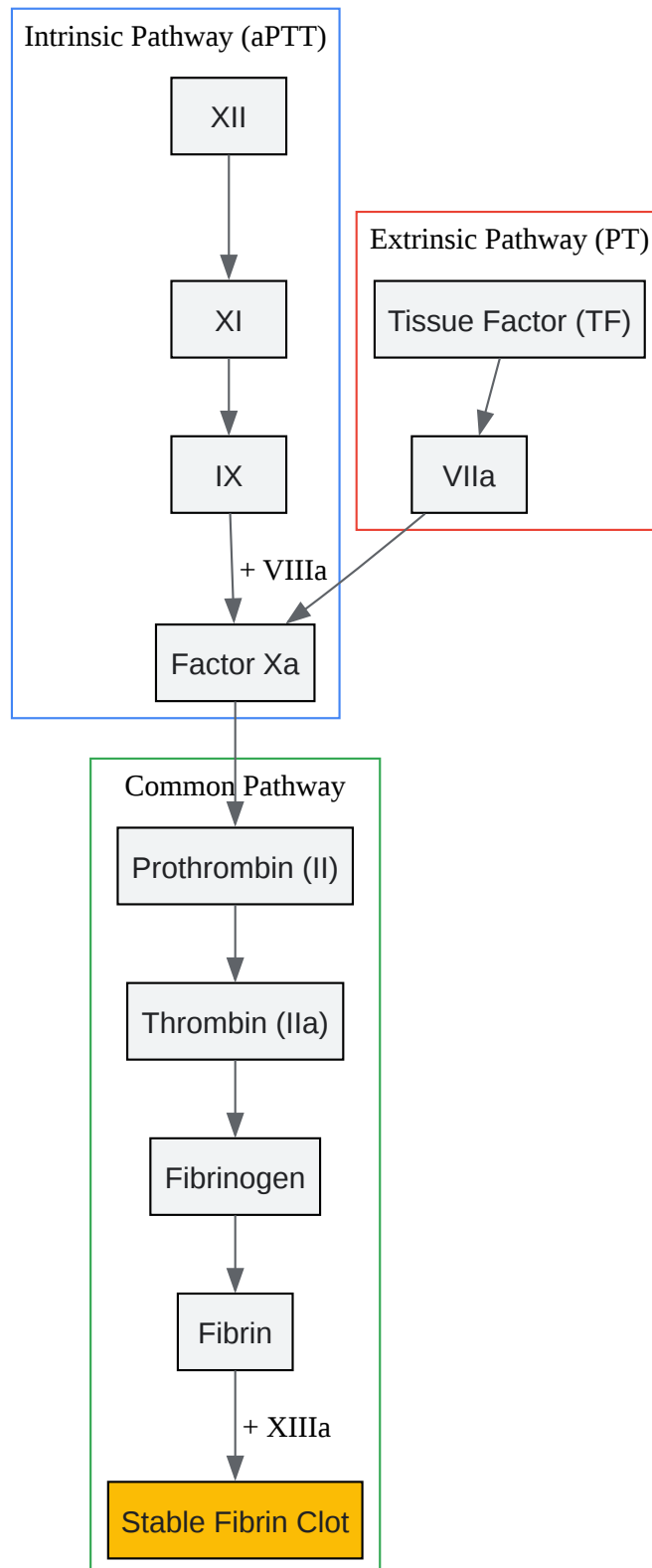

[Click to download full resolution via product page](#)

Caption: Simplified diagram of the blood coagulation cascade pathways.

This widely used model assesses the antithrombotic efficacy of a compound in a living organism.^{[17][18]}

- Causality: Topical application of ferric chloride to an artery induces oxidative damage to the vessel wall, triggering a physiological thrombotic response that closely mimics aspects of human thrombosis.^[17]
- Methodology:
 - Animal Model: Typically performed in mice or rats.
 - Procedure: a. Administer the test pyrazine compound or vehicle control to the animal via an appropriate route (e.g., oral gavage, intravenous injection). b. Surgically expose a target artery (e.g., carotid or mesenteric artery). c. Apply a small piece of filter paper saturated with FeCl₃ solution (e.g., 10%) to the artery for a few minutes. d. Remove the filter paper and monitor blood flow using a Doppler flow probe.
 - Endpoint: The primary endpoint is the time to complete vessel occlusion.
 - Data Analysis: Compare the occlusion times between the compound-treated group and the vehicle control group. A significant delay or prevention of occlusion indicates potent antithrombotic activity.^{[19][20]}

Future Outlook and Conclusion

The field of antithrombotic drug discovery is continually evolving, with a strong emphasis on improving safety and efficacy. Synthesized pyrazine compounds represent a versatile and promising platform for this research.^[21] Early studies have demonstrated their potential to inhibit both platelet aggregation and coagulation.^{[4][14]}

The key to unlocking their full potential lies in a systematic and rigorous evaluation process, as outlined in this guide. By combining targeted chemical synthesis with a robust battery of in vitro and in vivo assays, researchers can identify lead compounds with a superior therapeutic window. Future work should focus on elucidating precise mechanisms of action and optimizing pharmacokinetic properties to advance the most promising pyrazine derivatives toward clinical development.

References

- A Review Article on Safety and Efficacy of Newer Oral Anticoagulants in the Treatment of Cerebral Venous Sinus Thrombosis. (2023). Cureus. [\[Link\]](#)
- Weitz, J. I., & Fredenburgh, J. C. (2015). Overview of the New Oral Anticoagulants: Opportunities and Challenges. *Arteriosclerosis, Thrombosis, and Vascular Biology*. [\[Link\]](#)
- Petruszewicz, J., Yilinkou, R. G., Pilarski, B., & Kaliszan, R. (1992). Antithrombotic activity of a new pyrazine derivative determined by the mouse antithrombotic assay. *Pharmacology & Toxicology*. [\[Link\]](#)
- Miniyar, P. B., Murumkar, P. R., Patil, P. S., Barmade, M. A., & Bothara, K. G. (2013). Unequivocal Role of Pyrazine Ring in Medicinally Important Compounds: A Review. *Mini-Reviews in Medicinal Chemistry*. [\[Link\]](#)
- Miniyar, P. B., Murumkar, P. R., Patil, P. S., Barmade, M. A., & Bothara, K. G. (2013). Unequivocal Role of Pyrazine Ring in Medicinally Important Compounds: A Review. *ResearchGate*. [\[Link\]](#)
- Miniyar, P. B., Murumkar, P. R., Patil, P. S., Barmade, M. A., & Bothara, K. G. (2013). Unequivocal role of pyrazine ring in medicinally important compounds: a review. *Mini Reviews in Medicinal Chemistry*. [\[Link\]](#)
- Kaliszan, R., Petruszewicz, J., Pilarski, B., & Radwańska, U. (1991). Pyrazine CH- And NH-acids. Antithrombotic Activity and Chromatographic Behaviour. *European Journal of Medicinal Chemistry*. [\[Link\]](#)
- Miniyar, P. B., Murumkar, P. R., Patil, P. S., Barmade, M. A., & Bothara, K. G. (2013). Unequivocal Role of Pyrazine Ring in Medicinally Important Compounds: A Review. *Mini Reviews in Medicinal Chemistry*. [\[Link\]](#)
- Falati, S., Gross, P. L., Merrill-Skoloff, G., Sim, D., Flaumenhaft, R., Celi, A., Furie, B. C., & Furie, B. (2004). In Vivo Models of Platelet Function and Thrombosis. *Springer Nature Experiments*. [\[Link\]](#)

- Merli, G., & Spyropoulos, A. C. (2013). Novel oral anticoagulants: a review of new agents. *The American Journal of Managed Care*. [[Link](#)]
- Al-Hussain, F. A., & Al-Onazi, M. A. (2023). Thrombosis Models: An Overview of Common In Vivo and In Vitro Models of Thrombosis. *Vascular Health and Risk Management*. [[Link](#)]
- Nieswandt, B., Varga-Szabo, D., & Elvers, M. (2007). In Vivo Thrombus Formation in Murine Models. *Circulation Research*. [[Link](#)]
- Alquwaizani, M., & Al-Thubaiti, I. (2025). Novel Oral Anticoagulants in Modern Anticoagulation Therapy: A Clinical and Pharmacological Review. *International Journal of Pharmaceutical Sciences Review and Research*. [[Link](#)]
- Undas, A. (2014). New oral anticoagulants: their advantages and disadvantages compared with vitamin K antagonists in the prevention and treatment of patients with thromboembolic events. *Polskie Archiwum Medycyny Wewnętrznej*. [[Link](#)]
- Brodde, M. F., & Heitmeier, S. (2023). Animal and Cellular Models in Thrombosis and Hemostasis. *Hämostaseologie*. [[Link](#)]
- In vivo thrombosis models. (n.d.). Monash University. [[Link](#)]
- Zhang, Y., et al. (2023). Natural Products–Pyrazine Hybrids: A Review of Developments in Medicinal Chemistry. *Molecules*. [[Link](#)]
- Procedure for Prothrombin Time (PT), Activated Partial Thromboplastin Time (aPTT), and Thrombin Time (TT). (n.d.). Al-Mustaqbal University College. [[Link](#)]
- Petruszewicz, J., Turowska-Tyrk, I., & Kaliszan, R. (1995). Comparative studies of antiplatelet activity of nonsteroidal antiinflammatory drugs and new pyrazine CH- and NH-acids. *General Pharmacology: The Vascular System*. [[Link](#)]
- Ohta, A., Ohta, M., & Ogasawara, T. (1987). Anti-platelet aggregation activity of some pyrazines. *Yakugaku Zasshi: Journal of the Pharmaceutical Society of Japan*. [[Link](#)]
- Wang, J., et al. (2019). Anticoagulant and Antithrombotic Properties in Vitro and in Vivo of a Novel Sulfated Polysaccharide From Marine Green Alga *Monostroma nitidum*. *Frontiers in*

Pharmacology. [\[Link\]](#)

- Lee, W., et al. (2022). In Vitro Antithrombotic, Hematological Toxicity, and Inhibitor Studies of Protocatechuic, Isovanillic, and p-Hydroxybenzoic Acids from *Maclura tricuspidata* (Carr.) Bur. *Molecules*. [\[Link\]](#)
- Zhang, M., et al. (2025). Research Progress in In Vitro Screening Techniques for Natural Antithrombotic Medicines. *Molecules*. [\[Link\]](#)
- Jaradat, N., et al. (2022). In Vitro Activity of Some Medicinal Plants on Blood Coagulation. *Journal of Medicinal and Chemical Sciences*. [\[Link\]](#)
- Wang, J., et al. (2019). Anticoagulant and Antithrombotic Properties in Vitro and in Vivo of a Novel Sulfated Polysaccharide from Marine Green Alga *Monostroma nitidum*. *MDPI*. [\[Link\]](#)
- Poller, L. (1998). Standardization of coagulation tests. *Journal of the Medical Association of Thailand*. [\[Link\]](#)
- Lippi, G., & Favaloro, E. J. (2015). How to report results of prothrombin and activated partial thromboplastin times. *Annals of Translational Medicine*. [\[Link\]](#)
- CLSI H47-A2: One-Stage Prothrombin Time (PT) and Activated Partial Thromboplastin Time (APTT) Tests. (2010). U.S. Food and Drug Administration. [\[Link\]](#)
- Amato, R., et al. (2023). Inside the Mechanism of Action of Three Pyrazole Derivatives in Human Platelets and Endothelial Cells. *MDPI*. [\[Link\]](#)
- CLSI H47-A2: One-Stage Prothrombin Time (PT) and Activated Partial Thromboplastin Time (APTT) Tests. (2008). ANSI Webstore. [\[Link\]](#)
- Zhang, Y., et al. (2023). Natural Products–Pyrazine Hybrids: A Review of Developments in Medicinal Chemistry. *MDPI*. [\[Link\]](#)
- Rodrigues, C. R., et al. (2016). Antiplatelet pyrazolopyridines derivatives: pharmacological, biochemical and toxicological characterization. *Journal of Enzyme Inhibition and Medicinal Chemistry*. [\[Link\]](#)

- Kumar, H. V., et al. (2015). Synthesis, Free Radical Scavenging Activity, Antimicrobial And Molecular Docking Studies Of Novel Pyrazine 2-Carboxylic Acid Derivatives Of Piperazines. Research Journal of Pharmaceutical, Biological and Chemical Sciences. [\[https://www.rjpbcs.com/pdf/2015_6\(5\)/\[19\].pdf\]](https://www.rjpbcs.com/pdf/2015_6(5)/[19].pdf)[\(\[Link\]19\).pdf](#)

Need Custom Synthesis?

BenchChem offers custom synthesis for rare earth carbides and specific isotopic labeling.

Email: info@benchchem.com or [Request Quote Online](#).

Sources

- [1. img01.pharmablock.com](http://img01.pharmablock.com) [img01.pharmablock.com]
- [2. researchgate.net](http://researchgate.net) [researchgate.net]
- [3. Unequivocal role of pyrazine ring in medicinally important compounds: a review - PubMed](#) [pubmed.ncbi.nlm.nih.gov]
- [4. Antithrombotic activity of a new pyrazine derivative determined by the mouse antithrombotic assay - PubMed](#) [pubmed.ncbi.nlm.nih.gov]
- [5. Pyrazine CH- and NH-acids. Antithrombotic activity and chromatographic behaviour - PubMed](#) [pubmed.ncbi.nlm.nih.gov]
- [6. Comparative studies of antiplatelet activity of nonsteroidal antiinflammatory drugs and new pyrazine CH- and NH-acids - PubMed](#) [pubmed.ncbi.nlm.nih.gov]
- [7. ahajournals.org](http://ahajournals.org) [ahajournals.org]
- [8. New oral anticoagulants: their advantages and disadvantages compared with vitamin K antagonists in the prevention and treatment of patients with thromboembolic events - PMC](#) [pmc.ncbi.nlm.nih.gov]
- [9. ijrrjournal.com](http://ijrrjournal.com) [ijrrjournal.com]
- [10. ijpsjournal.com](http://ijpsjournal.com) [ijpsjournal.com]
- [11. Novel oral anticoagulants: a review of new agents - PubMed](#) [pubmed.ncbi.nlm.nih.gov]
- [12. Unequivocal Role of Pyrazine Ring in Medicinally Important Compou...: Ingenta Connect](#) [ingentaconnect.com]
- [13. pdf.benchchem.com](http://pdf.benchchem.com) [pdf.benchchem.com]
- [14. Anti-platelet aggregation activity of some pyrazines - PubMed](#) [pubmed.ncbi.nlm.nih.gov]

- [15. Recognized Consensus Standards: Medical Devices \[accessdata.fda.gov\]](#)
- [16. webstore.ansi.org \[webstore.ansi.org\]](#)
- [17. ahajournals.org \[ahajournals.org\]](#)
- [18. passamlab.com \[passamlab.com\]](#)
- [19. Anticoagulant and Antithrombotic Properties in Vitro and in Vivo of a Novel Sulfated Polysaccharide from Marine Green Alga Monostroma nitidum - PubMed \[pubmed.ncbi.nlm.nih.gov\]](#)
- [20. mdpi.com \[mdpi.com\]](#)
- [21. benthamdirect.com \[benthamdirect.com\]](#)
- [To cite this document: BenchChem. \[A Comparative Guide to the Antithrombotic Activity of Synthesized Pyrazine Compounds\]. BenchChem, \[2026\]. \[Online PDF\]. Available at: \[https://www.benchchem.com/product/b13650131/docs#a-comparative-guide-to-the-antithrombotic-activity-of-synthesized-pyrazine-compounds\]](#)

Disclaimer & Data Validity:

The information provided in this document is for Research Use Only (RUO) and is strictly not intended for diagnostic or therapeutic procedures. While BenchChem strives to provide accurate protocols, we make no warranties, express or implied, regarding the fitness of this product for every specific experimental setup.

Technical Support: The protocols provided are for reference purposes. Unsure if this reagent suits your experiment?

Need Industrial/Bulk Grade? [Request Custom Synthesis Quote](#)

BenchChem

Our mission is to be the trusted global source of essential and advanced chemicals, empowering scientists and researchers to drive progress in science and industry.

Contact

Address: 3281 E Guasti Rd
Ontario, CA 91761, United States
Phone: (601) 213-4426
Email: info@benchchem.com

Contact our Ph.D. Support Team for a compatibility check