

# Technical Support Center: Optimizing Methanol-18O Labeling Efficiency in Cell Cultures

**Author:** BenchChem Technical Support Team. **Date:** May 2026

## Compound of Interest

Compound Name: Methanol-18O

CAS No.: 5770-05-8

Cat. No.: B1365349

[Get Quote](#)

Welcome to the technical support center for **Methanol-18O** labeling in cell cultures. This guide is designed for researchers, scientists, and drug development professionals to provide in-depth troubleshooting advice and optimized protocols for successful metabolic labeling experiments. As Senior Application Scientists, we have compiled this resource based on field-proven insights and established scientific principles to ensure you can achieve high labeling efficiency and generate reliable data.

## The Principle of Methanol-18O Metabolic Labeling

**Methanol-18O** serves as a powerful tool for tracing the metabolic fate of one-carbon units within the cell. Once it enters the cell, it is metabolized, and the heavy oxygen isotope ( $^{18}\text{O}$ ) is incorporated into various downstream biomolecules. This allows for the quantitative analysis of metabolic fluxes and the turnover of specific molecules by mass spectrometry.

## Metabolic Fate of Methanol-18O in Mammalian Cells

Methanol readily enters cells and is primarily metabolized through the one-carbon (1C) cycle.<sup>[1]</sup>  
<sup>[2]</sup> The initial step involves its oxidation to formaldehyde, which then enters the folate cycle.

This pathway leads to the incorporation of the  $^{18}\text{O}$ -labeled carbon into the building blocks of essential macromolecules.

Key metabolic pathways and labeled products include:

- Serine and Glycine Synthesis: The one-carbon unit from methanol is utilized in the conversion of glycine to serine, and vice-versa, by serine hydroxymethyltransferase (SHMT).
- Methionine and S-adenosylmethionine (SAM) Synthesis: The labeled one-carbon unit is used in the remethylation of homocysteine to form methionine, which is then converted to SAM, the universal methyl group donor.
- Nucleotide Synthesis: Labeled one-carbon units are incorporated into purines and thymidylate, essential components of DNA and RNA.
- Lipid Synthesis: Through its integration into the SAM cycle, **Methanol- $^{18}\text{O}$**  can be traced into methylated lipids like phosphatidylcholine.[\[1\]](#)

Below is a diagram illustrating the central metabolic pathways involved in **Methanol- $^{18}\text{O}$**  assimilation.

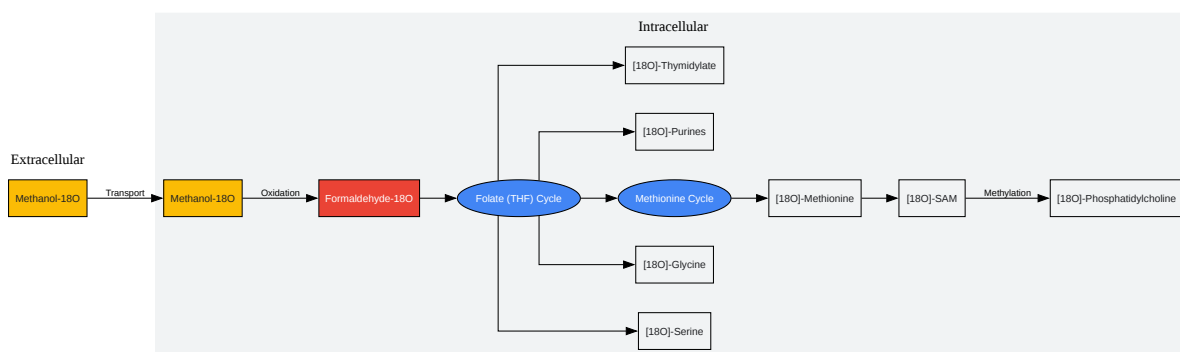

[Click to download full resolution via product page](#)

Caption: Metabolic pathway of **Methanol-18O** in mammalian cells.

## Troubleshooting Guide

This section addresses common issues encountered during **Methanol-18O** labeling experiments in a question-and-answer format.

### Low or Inconsistent Labeling Efficiency

Question: Why is my labeling efficiency low or inconsistent across samples?

Answer: Low labeling efficiency is a common problem that can be attributed to several factors. The key is to ensure a high and consistent concentration of **Methanol-18O** is available to the cells throughout the experiment.

- Suboptimal **Methanol-18O** Concentration: The concentration of **Methanol-18O** needs to be optimized for your specific cell line and experimental goals. A concentration that is too low will result in insufficient labeling, while an excessively high concentration can lead to cytotoxicity.[3][4]
- Incorrect Labeling Duration: The time required to reach isotopic steady-state varies depending on the cell type, its metabolic rate, and the turnover of the target molecules. Insufficient labeling time will lead to incomplete labeling.[5]
- Poor Cell Health: Cells that are not in a healthy, logarithmic growth phase will have altered metabolic rates, leading to reduced and inconsistent incorporation of the  $^{18}\text{O}$  label.[5] It is crucial to start experiments with healthy, actively dividing cells.[6][7]
- Contamination with  $\text{H}_2^{16}\text{O}$ : Residual unlabeled water or methanol from media components, buffers, or labware can dilute the isotopic enrichment of your labeling medium.[5]

Solutions:

Parameter	Recommendation	Rationale
Methanol-18O Concentration	Perform a dose-response curve to determine the optimal concentration (typically in the range of 0.1% to 1% v/v).	Balances labeling efficiency with potential cytotoxicity.
Labeling Duration	Conduct a time-course experiment to identify the minimum time required for maximum isotopic incorporation.	Ensures you capture the desired metabolic state without unnecessary cell stress.
Cell Health	Ensure cells are at 70-80% confluency and in the logarithmic growth phase before starting the experiment.	Maximizes metabolic activity and ensures reproducibility.
Minimizing Contamination	Use powdered media reconstituted with <sup>18</sup> O-water and Methanol-18O. Pre-rinse cell monolayers with a small volume of PBS to remove residual <sup>16</sup> O-containing media before adding the labeling medium.[5]	Reduces isotopic dilution from extraneous water sources.

## Cell Viability Issues

Question: My cells are showing signs of stress or dying after adding **Methanol-18O**. What can I do?

Answer: Methanol can be cytotoxic at higher concentrations.[3][4] It is essential to find a balance between efficient labeling and maintaining cell health.

- **Methanol Toxicity:** Methanol concentrations above a certain threshold can be toxic to cells, leading to decreased viability and altered metabolism. This threshold can vary significantly between cell lines.[3]

- **Solvent Effects:** The introduction of methanol can alter the properties of the cell culture medium, potentially affecting cell membrane integrity and protein function.
- **Extended Incubation:** Prolonged exposure to even low concentrations of methanol can be detrimental to some cell lines.

Solutions:

Issue	Troubleshooting Step	Scientific Rationale
High Cell Death	Determine the IC <sub>50</sub> of methanol for your specific cell line using a viability assay (e.g., MTT or Trypan Blue exclusion).	Establishes the cytotoxic threshold and informs the selection of a non-toxic labeling concentration.
Signs of Cell Stress	Start with a lower concentration of Methanol-18O (e.g., 0.1%) and gradually increase it. Monitor cell morphology and viability throughout the experiment.	Minimizes the initial shock to the cells and allows for adaptation.
Time-dependent Toxicity	If long-term labeling is required, consider a pulse-chase experiment where cells are labeled for a shorter period and then transferred to fresh, unlabeled medium.	Reduces the overall exposure to methanol while still allowing for the tracking of labeled molecules.

## Mass Spectrometry-Related Problems

**Question:** My mass spectrometry data is difficult to interpret, showing a mix of labeled and unlabeled species.

**Answer:** This indicates incomplete labeling or issues with sample preparation and data analysis. The goal is to achieve a clear and quantifiable mass shift corresponding to the incorporation of <sup>18</sup>O.

- **Incomplete Labeling:** As discussed previously, this can result from suboptimal labeling conditions, leading to a mixed population of molecules with varying degrees of  $^{18}\text{O}$  incorporation. This complicates data analysis and quantification.[8][9][10]
- **Back-Exchange:** The incorporated  $^{18}\text{O}$  atom can be lost and replaced by a  $^{16}\text{O}$  atom from water during sample processing, particularly if enzymatic steps are involved at a neutral or high pH.[8][11]
- **Improper Metabolite Extraction:** The method used to extract metabolites from the cells can significantly impact the quality of your sample. Inefficient extraction will result in low signal intensity, while harsh methods can degrade labile metabolites.

## Solutions:

Problem	Recommended Action	Rationale
Mixed Labeling States	Optimize labeling time and Methanol- $^{18}\text{O}$ concentration as described above. For proteomics, ensure complete enzymatic digestion in the presence of $\text{H}_2^{18}\text{O}$ to drive the reaction towards double labeling (+4 Da shift).[8]	A homogenous population of fully labeled peptides simplifies data analysis and improves quantification accuracy.
Oxygen Back-Exchange	Quench enzymatic reactions by acidification (e.g., adding formic acid).[8] Perform all post-labeling steps at low pH and temperature where possible.	Minimizes the potential for the labeled oxygen to be exchanged with oxygen from aqueous solutions.
Metabolite Extraction	Use a cold methanol-based extraction method to quench metabolism and efficiently extract a broad range of metabolites.[12][13][14][15][16]	Cold methanol rapidly inactivates enzymes and solubilizes a wide range of polar and non-polar metabolites.

## Experimental Protocols

### Optimizing Methanol-18O Concentration and Labeling Time

This protocol provides a framework for determining the optimal labeling conditions for your specific cell line.

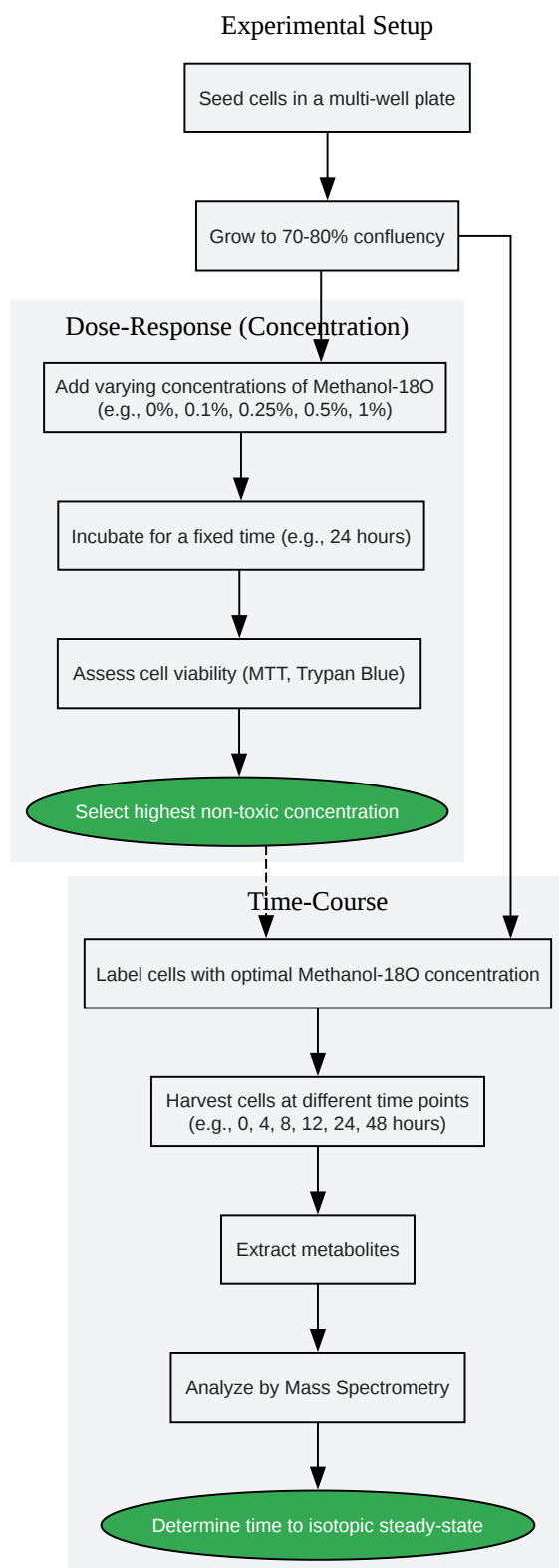

[Click to download full resolution via product page](#)

Caption: Workflow for optimizing **Methanol-18O** labeling conditions.

### Steps:

- Cell Seeding: Seed your cells in a multi-well plate (e.g., 12-well or 24-well) at a density that will result in 70-80% confluency on the day of the experiment.
- Dose-Response:
  - Prepare labeling media with a range of **Methanol-18O** concentrations (e.g., 0%, 0.1%, 0.25%, 0.5%, 1% v/v).
  - Replace the existing media with the labeling media.
  - Incubate for a standard duration (e.g., 24 hours).
  - Assess cell viability using your preferred method.
  - Select the highest concentration that does not significantly impact cell viability.
- Time-Course:
  - Using the optimal **Methanol-18O** concentration determined above, prepare a sufficient volume of labeling medium.
  - Replace the media in a new set of plates.
  - Harvest cells at various time points (e.g., 0, 4, 8, 12, 24, 48 hours).
  - Extract metabolites and analyze by mass spectrometry to determine the rate of  $^{18}\text{O}$  incorporation into your target molecule(s).
  - Identify the time point at which the labeling reaches a plateau (isotopic steady-state).

## Sample Preparation for Mass Spectrometry Analysis

This protocol outlines a general procedure for quenching metabolism and extracting metabolites from adherent cell cultures.

- Media Removal: Aspirate the labeling medium from the culture dish.

- **Washing:** Quickly wash the cells with ice-cold phosphate-buffered saline (PBS) to remove any remaining labeling medium. Aspirate the PBS completely.
- **Quenching and Extraction:**
  - Immediately add a sufficient volume of ice-cold 80% methanol (-20°C or colder) to cover the cell monolayer.[\[16\]](#)
  - Incubate at -20°C for 5-10 minutes to ensure complete inactivation of enzymes.
- **Cell Lysis and Collection:**
  - Scrape the cells from the dish into the methanol solution.
  - Transfer the cell lysate to a microcentrifuge tube.
  - To ensure complete lysis, you can perform three freeze-thaw cycles using liquid nitrogen and a 37°C water bath.[\[16\]](#)
- **Centrifugation:** Centrifuge the lysate at high speed (e.g., >13,000 rpm) for 15-30 minutes at 4°C to pellet cell debris and precipitated proteins.[\[12\]](#)
- **Supernatant Collection:** Carefully transfer the supernatant, which contains the extracted metabolites, to a new tube for analysis.
- **Sample Storage:** Store the extracted metabolites at -80°C until you are ready for mass spectrometry analysis.

## Frequently Asked Questions (FAQs)

Q1: Can I use **Methanol-18O** for SILAC-based experiments?

A1: **Methanol-18O** labeling is distinct from SILAC (Stable Isotope Labeling by Amino acids in Cell culture). SILAC involves metabolic incorporation of heavy amino acids over several cell doublings to label the entire proteome. **Methanol-18O** labeling is typically used for shorter-term experiments to track the flux through one-carbon metabolism and the turnover of specific molecules. The two techniques can be complementary but are used to answer different biological questions.

Q2: What is the expected mass shift I should look for?

A2: The mass shift depends on the number of  $^{18}\text{O}$  atoms incorporated into the molecule. For each  $^{18}\text{O}$  atom that replaces a  $^{16}\text{O}$  atom, you will observe a mass increase of approximately 2 Da. For molecules that incorporate a methyl group from the one-carbon pathway, you would expect to see a +2 Da shift. For molecules like peptides that can incorporate two oxygens during enzymatic reactions in  $^{18}\text{O}$ -water, a +4 Da shift is expected for complete labeling.[8][10]

Q3: How do I handle potential evaporation of methanol from my culture media?

A3: To minimize evaporation, use culture plates with tight-fitting lids and ensure the incubator has adequate humidity. For long-term experiments, consider using sealed flasks or plates with sealing tape. However, be mindful of gas exchange requirements for your cells.

Q4: Is it better to use  $^{18}\text{O}$ -water or **Methanol-18O** for my experiments?

A4: The choice depends on your research question.  $^{18}\text{O}$ -water is a more general metabolic label, as water is involved in numerous enzymatic reactions. **Methanol-18O** is more specific for tracing one-carbon metabolism and methylation events. If you are specifically interested in the folate and methionine cycles, **Methanol-18O** is the more direct and targeted approach.

Q5: My cells grow in suspension. How should I adapt the protocol?

A5: For suspension cells, the principles remain the same. To change the media, gently pellet the cells by centrifugation, aspirate the old media, and resuspend in the pre-warmed **Methanol-18O** labeling medium. The quenching and extraction steps are similar: pellet the cells, wash with cold PBS, and then add cold 80% methanol to the cell pellet.

## References

- 18O Stable Isotope Labeling in MS-based Proteomics - ResearchGate. Available from: [\[Link\]](#)
- Simultaneous Quantification and Identification Using 18O Labeling with an Ion Trap Mass Spectrometer and the Analysis Software Application “ZoomQuant” - PMC - NIH. Available from: [\[Link\]](#)
- 18O Stable Isotope Labeling in MS-based Proteomics - PMC. Available from: [\[Link\]](#)

- Simultaneous Identification and Quantification of Proteins by Differential  $^{16}\text{O}/^{18}\text{O}$  Labeling and UPLC-MS/MS Applied to Mouse Cerebellar Phosphoproteome Following Irradiation | Anticancer Research. Available from: [\[Link\]](#)
- $^{18}\text{O}$  Stable Isotope Labeling in MS-based Proteomics - Oxford Academic. Available from: [\[Link\]](#)
- Metabolism of Methanol in Plant Cells. Carbon-13 Nuclear Magnetic Resonance Studies. Available from: [\[Link\]](#)
- A Robust Method for Quantitative High-throughput Analysis of Proteomes by  $^{18}\text{O}$  Labeling. Available from: [\[Link\]](#)
- Metabolic Methanol: Molecular Pathways and Physiological Roles. Available from: [\[Link\]](#)
- Proteome Scale-Protein Turnover Analysis Using High Resolution Mass Spectrometric Data from Stable-Isotope Labeled Plants - PMC. Available from: [\[Link\]](#)
- Precise Estimation of In Vivo Protein Turnover Rates - bioRxiv. Available from: [\[Link\]](#)
- A method for automatically interpreting mass spectra of  $^{18}\text{O}$ -labeled isotopic clusters. Available from: [\[Link\]](#)
- An Optimized Method for Computing  $^{18}\text{O}/^{16}\text{O}$  Ratios of Differentially Stable-isotope Labeled Peptides in the Context of Post-digestion  $^{18}\text{O}$  Exchange/Labeling - PubMed Central. Available from: [\[Link\]](#)
- Metabolic Methanol: Molecular Pathways and Physiological Roles. Available from: [\[Link\]](#)
- (A) Methanol metabolic pathway. Each step of the reaction is tagged... - ResearchGate. Available from: [\[Link\]](#)
- Targeted Protein Half-Life Assays - Metabolic Solutions. Available from: [\[Link\]](#)
- Preparation of cell samples for metabolomics | Mass Spectrometry Research Facility. Available from: [\[Link\]](#)

- Effect of methanol fixation on single-cell RNA sequencing data - bioRxiv. Available from: [\[Link\]](#)
- Methanol in Plant Life - Frontiers. Available from: [\[Link\]](#)
- Flexible Quality Control for Protein Turnover Rates Using d2ome - MDPI. Available from: [\[Link\]](#)
- Quenching and Metabolites Extraction from adherent cell lines and cell supernatant for metabolic profiling - Metabolomics - The Wheelock Laboratory. Available from: [\[Link\]](#)
- Targeted 18O-Labeling for Improved Proteomic Analysis of Carbonylated Peptides by Mass Spectrometry - PMC. Available from: [\[Link\]](#)
- Time and Concentration Dependent Effects of Different Solvents on Proliferation of K562, HL60, HCT-116 and H929 Cell Lines. Available from: [\[Link\]](#)
- Multi-Omics Compatible Protocols for Preparation and Extraction of Biological Samples for Wide Coverage in Untargeted Metabolomics - Agilent. Available from: [\[Link\]](#)
- Extraction of Metabolome From Adherent Cell Lines. Available from: [\[Link\]](#)
- Comparative cytotoxic effects of methanol, ethanol and DMSO on human cancer cell lines | Biomedical Research and Therapy. Available from: [\[Link\]](#)
- Effect of methanol fixation on single-cell RNA sequencing of the murine dentate gyrus. Available from: [\[Link\]](#)
- Troubleshooting Quantitative Western Blots Hints and Tips - LICORbio™. Available from: [\[Link\]](#)
- Addressing Sources of Error in the Cell Viability Measurement Process | NIST. Available from: [\[Link\]](#)

### ***Need Custom Synthesis?***

*BenchChem offers custom synthesis for rare earth carbides and specific isotopic labeling.*

*Email: [info@benchchem.com](mailto:info@benchchem.com) or [Request Quote Online](#).*

## Sources

- 1. Metabolism of Methanol in Plant Cells. Carbon-13 Nuclear Magnetic Resonance Studies - PMC [[pmc.ncbi.nlm.nih.gov](https://pubmed.ncbi.nlm.nih.gov/)]
- 2. Frontiers | Methanol in Plant Life [[frontiersin.org](https://www.frontiersin.org/)]
- 3. [abis-files.ankara.edu.tr](https://abis-files.ankara.edu.tr/) [[abis-files.ankara.edu.tr](https://abis-files.ankara.edu.tr/)]
- 4. Comparative cytotoxic effects of methanol, ethanol and DMSO on human cancer cell lines | Biomedical Research and Therapy [[bmrat.org](https://www.bmrat.org/)]
- 5. [pdf.benchchem.com](https://pdf.benchchem.com/) [[pdf.benchchem.com](https://pdf.benchchem.com/)]
- 6. 细胞培养故障排除 [[sigmaaldrich.com](https://www.sigmaaldrich.com/)]
- 7. Cell culture troubleshooting | Proteintech Group [[ptglab.com](https://www.ptglab.com/)]
- 8. [pdf.benchchem.com](https://pdf.benchchem.com/) [[pdf.benchchem.com](https://pdf.benchchem.com/)]
- 9. [researchgate.net](https://www.researchgate.net/) [[researchgate.net](https://www.researchgate.net/)]
- 10. Simultaneous Quantification and Identification Using 18O Labeling with an Ion Trap Mass Spectrometer and the Analysis Software Application “ZoomQuant” - PMC [[pmc.ncbi.nlm.nih.gov](https://pubmed.ncbi.nlm.nih.gov/)]
- 11. [academic.oup.com](https://academic.oup.com/) [[academic.oup.com](https://academic.oup.com/)]
- 12. Preparation of cell samples for metabolomics | Mass Spectrometry Research Facility [[massspec.chem.ox.ac.uk](https://massspec.chem.ox.ac.uk/)]
- 13. Cell Sample Collection & Metabolite Extraction in Metabolomics [[metabolomics.creative-proteomics.com](https://www.metabolomics.creative-proteomics.com/)]
- 14. [metabolomics.se](https://www.metabolomics.se/) [[metabolomics.se](https://www.metabolomics.se/)]
- 15. [agilent.com](https://www.agilent.com/) [[agilent.com](https://www.agilent.com/)]
- 16. [cri.utsw.edu](https://cri.utsw.edu/) [[cri.utsw.edu](https://cri.utsw.edu/)]
- To cite this document: BenchChem. [Technical Support Center: Optimizing Methanol-18O Labeling Efficiency in Cell Cultures]. BenchChem, [2026]. [Online PDF]. Available at: [<https://www.benchchem.com/product/b1365349/docs#technical-support-center-optimizing-methanol-18o-labeling-efficiency-in-cell-cultures>]

---

### Disclaimer & Data Validity:

The information provided in this document is for Research Use Only (RUO) and is strictly not intended for diagnostic or therapeutic procedures. While BenchChem strives to provide accurate protocols, we make no warranties, express or implied, regarding the fitness of this product for every specific experimental setup.

**Technical Support:** The protocols provided are for reference purposes. Unsure if this reagent suits your experiment?

**Need Industrial/Bulk Grade?** [Request Custom Synthesis Quote](#)

## BenchChem

Our mission is to be the trusted global source of essential and advanced chemicals, empowering scientists and researchers to drive progress in science and industry.

### Contact

Address: 3281 E Guasti Rd  
Ontario, CA 91761, United States  
Phone: (601) 213-4426  
Email: [info@benchchem.com](mailto:info@benchchem.com)

[Contact our Ph.D. Support Team for a compatibility check](#)