

Technical Support Center: Optimization of Z-Gly-Ile-Ala-OH Analysis

Author: BenchChem Technical Support Team. **Date:** May 2026

Compound of Interest

Compound Name: Z-Gly-Ile-Ala-OH

Cat. No.: B1365552

[Get Quote](#)

Current Status: Operational Subject: Resolving Peak Tailing in **Z-Gly-Ile-Ala-OH**
(Carbobenzoxy-Glycyl-Isoleucyl-Alanine) Applicable Techniques: RP-HPLC, LC-MS

Executive Summary

Z-Gly-Ile-Ala-OH is a hydrophobic, acidic tripeptide. The N-terminal Carbobenzoxy (Z) group removes the basicity typically associated with the N-terminus, leaving the C-terminal carboxylic acid ($pK_a \approx 3.4$) as the primary ionizable group.

Peak tailing for this specific molecule is rarely caused by the "silanol-amine" interactions common in standard peptides. Instead, it is almost exclusively driven by two factors:

- Mixed Ionization States: Operating at a pH near the pK_a (pH 3–4), resulting in a mix of protonated () and deprotonated () species.
- Strong Solvent Effects: The hydrophobicity of the Z-group often necessitates dissolving the sample in DMSO or MeOH, leading to hydrodynamic instability at the column head.

Part 1: Diagnostic Workflow

Before altering your method, use this logic flow to identify the root cause.

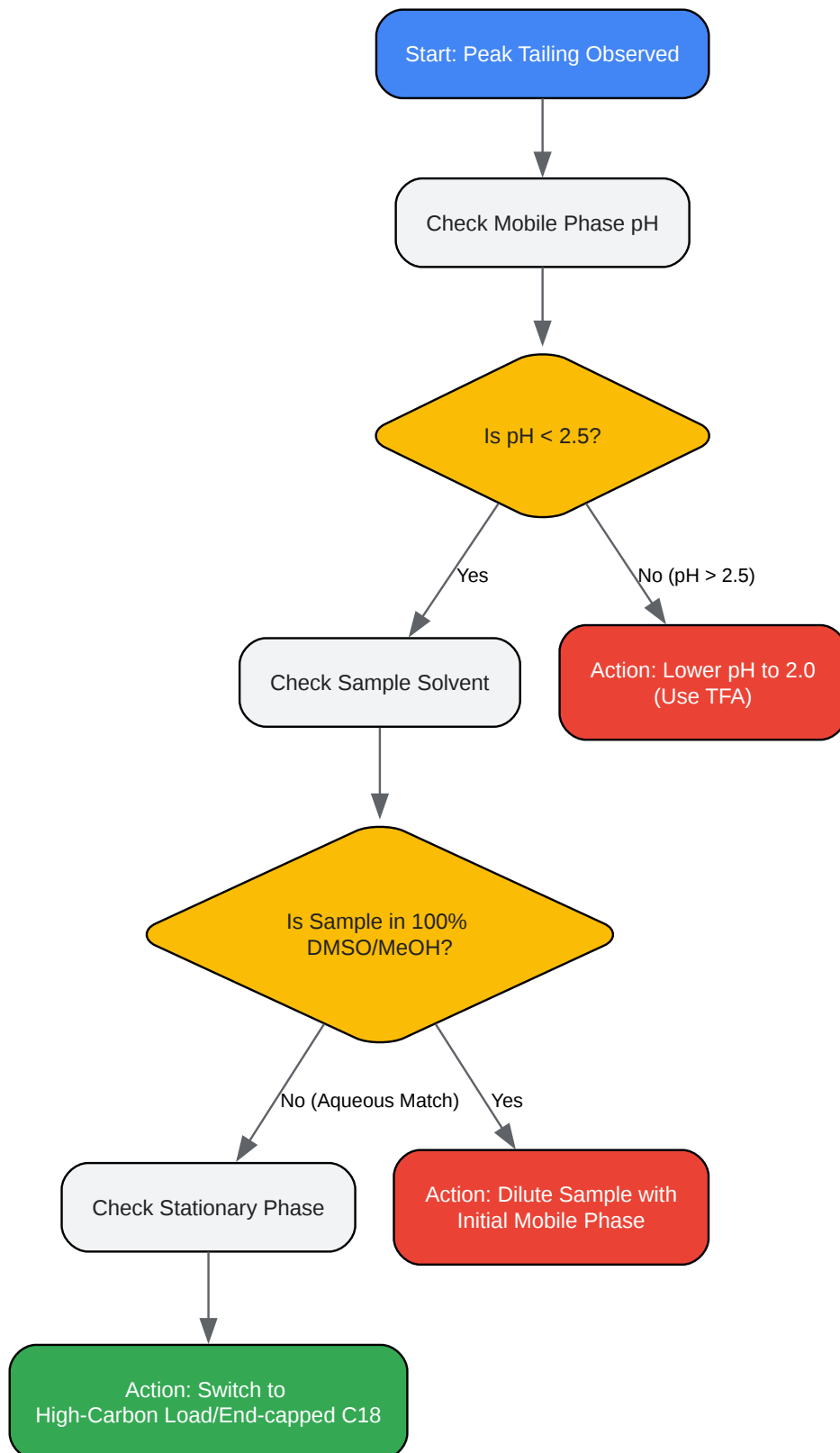

[Click to download full resolution via product page](#)

Figure 1: Diagnostic logic tree for isolating the source of peak asymmetry in acidic hydrophobic peptides.

Part 2: Technical Modules & Solutions

Module A: Mobile Phase Chemistry (The Acidic Driver)

The Science: The C-terminal alanine has a carboxylic acid pKa of approximately 3.4.

- At pH 3.4: 50% of the molecules are neutral () and 50% are ionized (). These two species interact differently with the stationary phase, causing the peak to "smear" or tail.^{[1][2][3][4]}
- At pH 7.0: The molecule is fully ionized (). While this eliminates mixed states, the ionized form is less retained and may interact with metals in the system.
- At pH < 2.5: The molecule is fully protonated (). This is the required state for sharp peaks.

Protocol 1: The "Acid Suppression" Mobile Phase

- Reagent: Trifluoroacetic Acid (TFA) is superior to Formic Acid (FA) for this molecule. TFA provides a lower pH (stronger acid) and acts as an ion-pairing agent for any residual backbone interactions.
- Preparation:
 - Mobile Phase A: Water + 0.1% (v/v) TFA (pH ≈ 2.0).
 - Mobile Phase B: Acetonitrile + 0.1% (v/v) TFA.

- Note: Do not use Acetate or Formate buffers; their buffering capacity at pH 2.0 is negligible.

Data Comparison: TFA vs. Formic Acid

Parameter	0.1% Formic Acid (pH ~2.7)	0.1% TFA (pH ~2.0)	Technical Verdict
Ionization State	~80% Protonated	>99% Protonated	TFA ensures single species.
Peak Width (50%)	Broad	Sharp	TFA suppresses silanol activity.
Tailing Factor ()	1.4 - 1.8	1.0 - 1.15	TFA is required.

Module B: Sample Solvent Mismatch (The Hydrophobic Trap)

The Science: **Z-Gly-Ile-Ala-OH** is hydrophobic. Researchers often dissolve it in 100% DMSO or Methanol. When a 10 µL slug of strong solvent enters a mobile phase of 95% Water, the peptide precipitates momentarily at the interface or travels faster than the mobile phase, causing "fronting" that looks like tailing, or split peaks.

Protocol 2: Injection Solvent Optimization

- Dissolution: Dissolve the pure peptide in a minimal volume of DMSO (e.g., 1 mg in 50 µL).
- Dilution: Immediately dilute this stock 10-fold with Mobile Phase A (Water/0.1% TFA).
 - Final Composition: 10% DMSO / 90% Aqueous Acid.
- Verification: If the solution turns cloudy, the peptide has precipitated. You must increase the organic content slightly (e.g., 20% ACN / 80% Water) until clear, but keep it as weak as possible.

Module C: Stationary Phase Selection

The Science: While the Z-group blocks the amine, the peptide backbone (amides) can still hydrogen bond with free silanols on the silica surface.

Recommended Column Specs:

- Bonded Phase: C18 (Octadecyl).
- End-capping: Essential. "Triple end-capped" or "Sterically protected" phases prevent backbone H-bonding.
- Pore Size: 80–120 Å (Standard for small peptides).
- Carbon Load: High (>15%) to maximize hydrophobic retention of the Z-group.

Part 3: Mechanistic Visualization

Understanding the molecular behavior of **Z-Gly-Ile-Ala-OH** under different pH conditions is critical for method development.

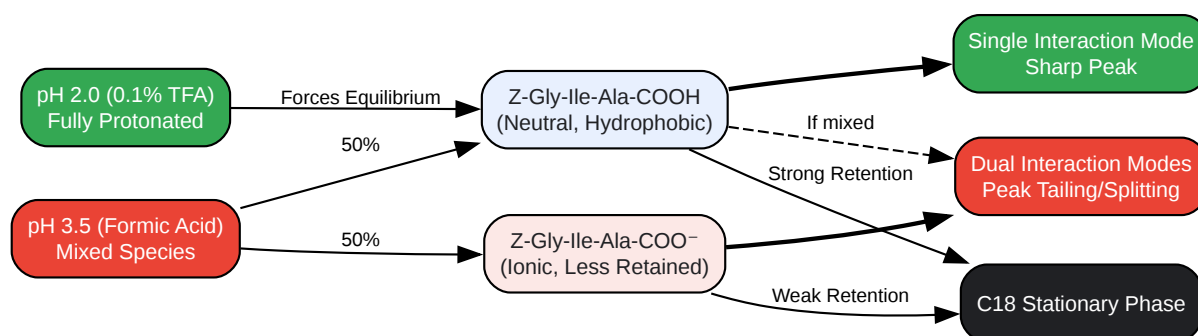

[Click to download full resolution via product page](#)

Figure 2: Impact of pH on the ionization equilibrium of the C-terminal carboxylic acid and resulting chromatographic performance.

Part 4: Frequently Asked Questions (FAQs)

Q1: I cannot use TFA because I am using LC-MS and it suppresses my signal. What is the alternative?

- Answer: Use Difluoroacetic Acid (DFA) or a mix of 0.1% Formic Acid + 10-20 mM Ammonium Formate.
 - Why: Ammonium formate buffers the solution better than Formic Acid alone, stabilizing the pH around 3.75. While this is not pH 2.0, a stable pH is better than a drifting one. However, DFA is the modern "Gold Standard" alternative to TFA for peptide MS work [1].

Q2: My peak is tailing, but also splitting into two distinct peaks. Is this an isomer?

- Answer: Likely not. Z-protected peptides are prone to atropisomerism (rotation around the carbamate bond) in NMR, but in HPLC, splitting is usually solvent mismatch.
 - Test: Inject 1/10th of the volume. If the peaks merge into one, it was a solvent effect (Module B).

Q3: Does the Z-group degrade?

- Answer: The Z-group is stable under standard acidic HPLC conditions. However, it is sensitive to strong bases or catalytic hydrogenation. Ensure your autosampler is not using a basic needle wash (pH > 9).

References

- Waters Corporation. (2023). Comparing Mobile Phase Additives for the Separation of mAb Tryptic Peptides: A Case Study on Formic, Difluoroacetic, and Trifluoroacetic Acid.[5][6][Link](#)
- Chromatography Online. (2019). HPLC Diagnostic Skills II – Tailing Peaks.[Link](#)
- McCalley, D. V. (2004).[6] Effect of buffer on peak shape of peptides in reversed-phase high performance liquid chromatography. Journal of Chromatography A, 1038(1-2), 77-84. [Link](#)
- Agilent Technologies. (2019).[7] A Tail of Two Peaks: Troubleshooting Poor Peak Shape.[Link](#)

Need Custom Synthesis?

BenchChem offers custom synthesis for rare earth carbides and specific isotopic labeling.

Email: info@benchchem.com or [Request Quote Online](#).

Sources

- [1. acdlabs.com \[acdlabs.com\]](#)
- [2. elementlabsolutions.com \[elementlabsolutions.com\]](#)
- [3. chromatographyonline.com \[chromatographyonline.com\]](#)
- [4. hplc.eu \[hplc.eu\]](#)
- [5. waters.com \[waters.com\]](#)
- [6. Effect of buffer on peak shape of peptides in reversed-phase high performance liquid chromatography - PubMed \[pubmed.ncbi.nlm.nih.gov\]](#)
- [7. agilent.com \[agilent.com\]](#)
- To cite this document: BenchChem. [Technical Support Center: Optimization of Z-Gly-Ile-Ala-OH Analysis]. BenchChem, [2026]. [Online PDF]. Available at: [\[https://www.benchchem.com/product/b1365552/docs#technical-support-center-optimization-of-z-gly-ile-ala-oh-analysis\]](https://www.benchchem.com/product/b1365552/docs#technical-support-center-optimization-of-z-gly-ile-ala-oh-analysis)

Disclaimer & Data Validity:

The information provided in this document is for Research Use Only (RUO) and is strictly not intended for diagnostic or therapeutic procedures. While BenchChem strives to provide accurate protocols, we make no warranties, express or implied, regarding the fitness of this product for every specific experimental setup.

Technical Support: The protocols provided are for reference purposes. Unsure if this reagent suits your experiment?

Need Industrial/Bulk Grade? [Request Custom Synthesis Quote](#)

BenchChem

Our mission is to be the trusted global source of essential and advanced chemicals, empowering scientists and researchers to drive progress in science and industry.

Contact

Address: 3281 E Guasti Rd

Ontario, CA 91761, United States

Phone: (601) 213-4426

Email: info@benchchem.com

[Contact our Ph.D. Support Team for a compatibility check](#)