

Determining the Cellular IC50 of PRMT4-IN-1: Application Notes and Protocols

Author: BenchChem Technical Support Team. **Date:** April 2026

Compound of Interest

Compound Name: PRMT4-IN-1

Cat. No.: B13646677

[Get Quote](#)

For Researchers, Scientists, and Drug Development Professionals

Abstract

This document provides detailed application notes and protocols for determining the half-maximal inhibitory concentration (IC50) of **PRMT4-IN-1** in a cellular context. Protein Arginine Methyltransferase 4 (PRMT4), also known as Coactivator-Associated Arginine Methyltransferase 1 (CARM1), is a key enzyme that catalyzes the transfer of methyl groups to arginine residues on histone and non-histone proteins, playing a crucial role in transcriptional regulation and signal transduction.[1][2] Dysregulation of PRMT4 activity has been implicated in various diseases, including cancer, making it a significant target for therapeutic intervention. **PRMT4-IN-1** is a selective inhibitor of PRMT4 with a reported biochemical IC50 of 3.2 nM.[3] This protocol outlines a robust Western blot-based method to quantify the cellular potency of **PRMT4-IN-1** by monitoring the methylation status of known PRMT4 substrates, such as BAF155 and MED12.[1][4]

Introduction

PRMT4 is a Type I protein arginine methyltransferase that asymmetrically dimethylates its substrates.[1] It is involved in a multitude of cellular processes, including the regulation of gene

expression through the methylation of histone H3 at arginines 17 and 26 (H3R17, H3R26) and various non-histone proteins like the transcriptional coactivators p300/CBP and the SWI/SNF chromatin remodeling complex subunit BAF155.[4][5] Given its role in cellular proliferation and survival pathways, inhibiting PRMT4 has emerged as a promising strategy in oncology.

PRMT4-IN-1 is a potent and selective small molecule inhibitor of PRMT4. To evaluate its efficacy within a cellular environment, it is essential to determine its cellular IC50. This value represents the concentration of the inhibitor required to reduce the PRMT4 methyltransferase activity by 50% in living cells. The following protocol provides a detailed methodology for a Western blot-based assay, a widely accepted method for quantifying the inhibition of post-translational modifications. This assay directly measures the on-target effect of **PRMT4-IN-1** by assessing the methylation levels of endogenous PRMT4 substrates.

Signaling Pathway and Mechanism of Inhibition

PRMT4 acts as a transcriptional coactivator by methylating histone and non-histone proteins, which in turn modulates gene expression. The mechanism of action for many PRMT4 inhibitors, including presumably **PRMT4-IN-1**, involves competitive inhibition at the S-adenosylmethionine (SAM) binding site, preventing the transfer of a methyl group to its substrates. By inhibiting PRMT4, the downstream methylation events are blocked, leading to alterations in gene expression and cellular phenotypes such as reduced proliferation, as has been observed in MCF7 breast cancer cells treated with **PRMT4-IN-1**. [3][6]

PRMT4 Signaling and Inhibition

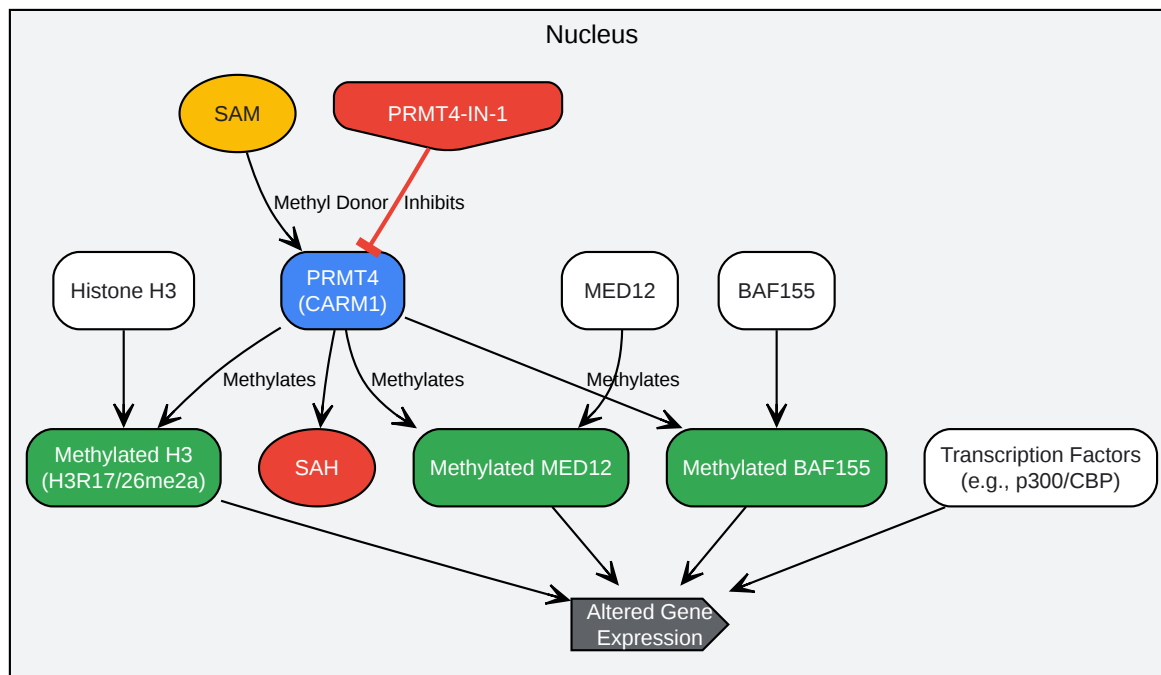

[Click to download full resolution via product page](#)

Caption: PRMT4 signaling pathway and mechanism of **PRMT4-IN-1** inhibition.

Experimental Protocols

This section details the protocol for determining the cellular IC₅₀ of **PRMT4-IN-1** using a Western blot-based assay to measure the methylation of the endogenous PRMT4 substrate, BAF155 or MED12.

Cell Culture and Treatment

- Cell Line Selection: Human embryonic kidney cells (HEK293T) or human breast cancer cells (MCF7) are suitable for this assay as they express detectable levels of PRMT4 and its substrates.

- **Cell Seeding:** Seed the selected cells in 6-well plates at a density that will result in 70-80% confluency at the time of harvesting.
- **Inhibitor Preparation:** Prepare a stock solution of **PRMT4-IN-1** in DMSO (e.g., 10 mM). From this stock, prepare a series of dilutions in cell culture medium to achieve the desired final concentrations for the dose-response curve. A suggested starting range is 0.01, 0.1, 0.3, 1, 3, 10, 30, 100 μ M. Include a vehicle control (DMSO only).
- **Cell Treatment:** Once the cells have adhered and reached approximately 50% confluency, replace the medium with the medium containing the different concentrations of **PRMT4-IN-1** or vehicle control.
- **Incubation:** Incubate the cells for 48 to 72 hours. A 72-hour incubation period has been shown to be effective for observing changes in methylation for other PRMT4 inhibitors.^[5]

Cell Lysis and Protein Quantification

- **Harvesting:** After the incubation period, wash the cells twice with ice-cold PBS.
- **Lysis:** Lyse the cells in RIPA buffer supplemented with protease and phosphatase inhibitors.
- **Protein Quantification:** Determine the protein concentration of each lysate using a BCA protein assay kit according to the manufacturer's instructions.

Western Blotting

- **Sample Preparation:** Normalize the protein concentration for all samples. Prepare the samples for SDS-PAGE by adding Laemmli sample buffer and heating at 95°C for 5 minutes.
- **SDS-PAGE:** Load equal amounts of protein (e.g., 20-30 μ g) per lane onto a polyacrylamide gel and perform electrophoresis.
- **Protein Transfer:** Transfer the separated proteins to a PVDF membrane.
- **Blocking:** Block the membrane with 5% non-fat dry milk or BSA in Tris-buffered saline with 0.1% Tween 20 (TBST) for 1 hour at room temperature.

- Primary Antibody Incubation: Incubate the membrane overnight at 4°C with the following primary antibodies diluted in blocking buffer:
 - Anti-asymmetric dimethyl-Arginine (for BAF155 or MED12)
 - Anti-total BAF155 or Anti-total MED12
 - Anti-PRMT4 (optional, to check for effects on enzyme level)
 - Anti-GAPDH or Anti- β -actin (as a loading control)
- Secondary Antibody Incubation: Wash the membrane three times with TBST and then incubate with the appropriate HRP-conjugated secondary antibody for 1 hour at room temperature.
- Detection: Wash the membrane again three times with TBST. Detect the signal using an enhanced chemiluminescence (ECL) substrate and an appropriate imaging system.

Data Analysis and IC50 Determination

- Densitometry: Quantify the band intensities for the methylated substrate and the total substrate for each concentration of **PRMT4-IN-1**.
- Normalization: Normalize the methylated substrate signal to the total substrate signal for each lane. Further normalize this value to the loading control to account for any loading inaccuracies.
- IC50 Calculation: Plot the normalized methylation levels against the logarithm of the **PRMT4-IN-1** concentration. Fit the data to a four-parameter logistic (4PL) curve to determine the IC50 value.

IC50 Determination Workflow

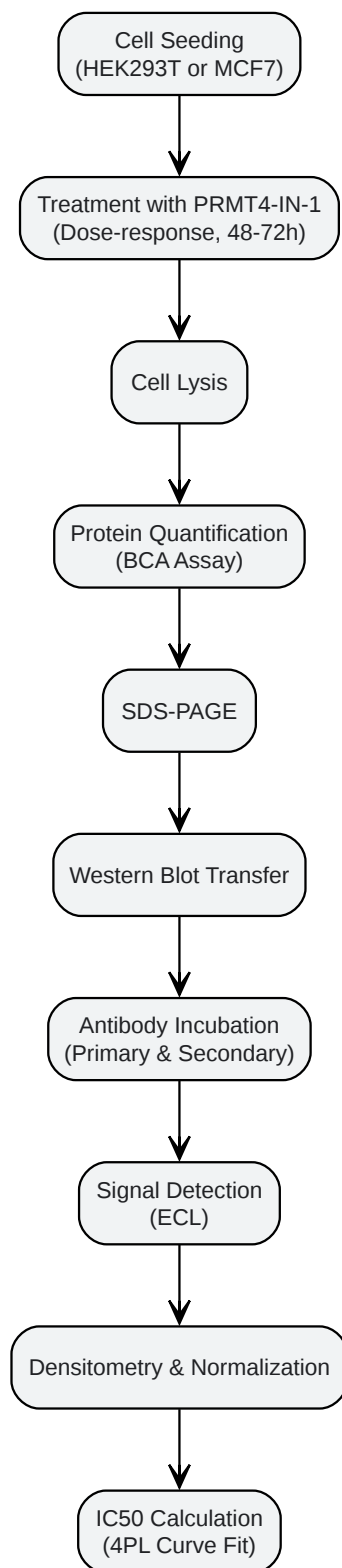

[Click to download full resolution via product page](#)

Caption: Workflow for cellular IC50 determination of **PRMT4-IN-1**.

Data Presentation

The quantitative data obtained from the Western blot analysis should be summarized in a clear and structured table to facilitate comparison and interpretation.

PRMT4-IN-1 [μM]	Normalized Methylated BAF155/MED12 Intensity (Arbitrary Units)	% Inhibition
0 (Vehicle)	1.00	0
0.01	[Experimental Value]	[Calculated Value]
0.1	[Experimental Value]	[Calculated Value]
0.3	[Experimental Value]	[Calculated Value]
1	[Experimental Value]	[Calculated Value]
3	[Experimental Value]	[Calculated Value]
10	[Experimental Value]	[Calculated Value]
30	[Experimental Value]	[Calculated Value]
100	[Experimental Value]	[Calculated Value]
Cellular IC50 (μM)	\multicolumn{2}{c}{ } [Calculated from Curve Fit]	

Summary of Quantitative Data for Known PRMT4 Inhibitors

To provide context, the following table summarizes the reported cellular IC50 values for other known PRMT4 inhibitors determined using similar Western blot-based assays.

Inhibitor	Cell Line	Substrate Monitored	Incubation Time (h)	Cellular IC50 (µM)	Reference
TP-064	HEK293T	BAF155-Rme2a	48	Not explicitly stated, but dose-dependent decrease shown	[1]
MS049	HEK293	Med12-Rme2a	72	1.4 ± 0.1	[5]

This information can serve as a benchmark for the expected potency of PRMT4 inhibitors in a cellular context. The cellular IC50 is generally expected to be higher than the biochemical IC50 due to factors such as cell permeability and target engagement in a complex cellular environment.

Need Custom Synthesis?

BenchChem offers custom synthesis for rare earth carbides and specific isotopic labeling.

Email: info@benchchem.com or [Request Quote Online](#).

References

- [1. PRMT4 \(CARM1\) cellular assay – openlabnotebooks.org \[openlabnotebooks.org\]](https://openlabnotebooks.org)
- [2. PRMT4/CARM1 Antibody | Cell Signaling Technology \[cellsignal.com\]](https://cellsignal.com)
- [3. medchemexpress.com \[medchemexpress.com\]](https://medchemexpress.com)
- [4. CARM1 Methylates Chromatin Remodeling Factor BAF155 to Enhance Tumor Progression and Metastasis - PMC \[pmc.ncbi.nlm.nih.gov\]](https://pubmed.ncbi.nlm.nih.gov/21111111/)
- [5. Discovery of a Potent, Selective and Cell-active Dual Inhibitor of Protein Arginine Methyltransferase 4 and Protein Arginine Methyltransferase 6 - PMC \[pmc.ncbi.nlm.nih.gov\]](https://pubmed.ncbi.nlm.nih.gov/21111112/)
- [6. amsbio.com \[amsbio.com\]](https://amsbio.com)
- To cite this document: BenchChem. [Determining the Cellular IC50 of PRMT4-IN-1: Application Notes and Protocols]. BenchChem, [2026]. [Online PDF]. Available at:

[<https://www.benchchem.com/product/b13646677/docs#determining-the-cellular-ic50-of-prmt4-in-1-application-notes-and-protocols>]

Disclaimer & Data Validity:

The information provided in this document is for Research Use Only (RUO) and is strictly not intended for diagnostic or therapeutic procedures. While BenchChem strives to provide accurate protocols, we make no warranties, express or implied, regarding the fitness of this product for every specific experimental setup.

Technical Support: The protocols provided are for reference purposes. Unsure if this reagent suits your experiment?

Need Industrial/Bulk Grade? [Request Custom Synthesis Quote](#)

BenchChem

Our mission is to be the trusted global source of essential and advanced chemicals, empowering scientists and researchers to drive progress in science and industry.

Contact

Address: 3281 E Guasti Rd
Ontario, CA 91761, United States
Phone: (601) 213-4426
Email: info@benchchem.com

[Contact our Ph.D. Support Team for a compatibility check](#)