

Technical Support Center: Phe-Tyr Mass Spectrometry Fragmentation

Author: BenchChem Technical Support Team. **Date:** May 2026

Compound of Interest

Compound Name: Phe-Tyr
Cat. No.: B13640099

[Get Quote](#)

This technical support center provides troubleshooting guidance and answers to frequently asked questions for researchers, scientists, and drug development professionals encountering issues with Phenylalanine-Tyrosine (**Phe-Tyr**) dipeptide fragmentation in mass spectrometry.

Frequently Asked Questions (FAQs) & Troubleshooting

Q1: What is the expected protonated molecular ion ($[M+H]^+$) for **Phe-Tyr**?

The theoretical monoisotopic mass of **Phe-Tyr** ($C_{18}H_{20}N_2O_4$) is 328.1423 Da.^[1] Therefore, you should be looking for the singly charged precursor ion $[M+H]^+$ at an m/z of approximately 329.1496.

Q2: I don't see any precursor ion for **Phe-Tyr**. What are the possible causes?

Several factors could lead to a lack of precursor ion signal. Consider the following troubleshooting steps:

- **Sample Purity and Concentration:** Ensure your sample is free from contaminants like salts, detergents, or polymers (e.g., PEG) that can suppress ionization.^[2] If the concentration is

too low, the signal may be indistinguishable from noise. Consider concentrating your sample.

- **Instrument Calibration:** Verify that your mass spectrometer is properly calibrated. Using a standard calibration solution is recommended.
- **Ionization Source Parameters:** Optimize your electrospray ionization (ESI) source settings. Adjust the spray voltage, gas flow rates, and temperature to maximize the signal for your specific analyte and solvent system.
- **Sample Preparation:** Peptides may be lost during sample cleanup.[3] Ensure that the pH of your sample is appropriate for binding to desalting columns (e.g., pH < 3 for C18 columns).

Q3: I see the precursor ion, but there is poor or no fragmentation. What should I do?

This is a common issue, often related to the energy applied for fragmentation.

- **Collision Energy (CE):** The most frequent reason for a lack of fragmentation is insufficient collision energy.[2] The optimal CE depends on the peptide's mass, charge state, and sequence. It is advisable to perform a collision energy optimization experiment for **Phe-Tyr** or use a stepped/ramped collision energy approach.[2]
- **Collision Gas:** Confirm that the collision gas (e.g., nitrogen or argon) is flowing at the recommended pressure. An absence of collision gas will prevent fragmentation.
- **Precursor Ion Selection:** Ensure the mass spectrometer is correctly isolating the precursor ion (m/z 329.15) for fragmentation. An issue with the quadrupole or ion trap could prevent the target m/z from entering the collision cell.

Q4: I am seeing unexpected fragment ions or a very complex spectrum. What could be the cause?

- **Contamination:** The complexity might arise from co-eluting contaminants in your sample. Ensure proper sample cleanup and high-purity, LC-MS grade solvents.
- **In-source Fragmentation:** The **Phe-Tyr** dipeptide might be fragmenting within the ionization source before it reaches the collision cell. This can be mitigated by optimizing the ion source conditions to be "softer" (e.g., reducing temperatures or voltages).

- **Multiple Precursors:** The instrument might be isolating and fragmenting multiple precursor ions simultaneously if the isolation window is too wide. This can happen in complex samples. Ensure your isolation window is set appropriately for your instrument and sample complexity.

Q5: I only observe the y_1 ion but not the b_1 ion. What does this indicate?

Observing the y_1 ion (Tyrosine) but not the b_1 ion (Phenylalanine) is a relatively common scenario in peptide fragmentation. This can be due to the intrinsic properties of the amino acids and the fragmentation process. The stability of the resulting fragment ions plays a significant role. In some cases, the y -ion series is more stable and therefore more predominantly observed. While this pattern can still confirm the sequence, optimizing collision energy may help to promote the formation of the b_1 ion.

Phe-Tyr Fragmentation Data

The primary fragmentation of peptides in Collision-Induced Dissociation (CID) occurs at the peptide bond, leading to the formation of b - and y -ions.[4] For the dipeptide **Phe-Tyr**, the following fragment ions are expected:

Ion Type	Sequence	Theoretical m/z ($[M+H]^+$)
Precursor	Phe-Tyr	329.15
b_1	Phe	148.08
y_1	Tyr	182.08
Immonium Ion	Phe	120.08
Immonium Ion	Tyr	136.08

Note: The m/z values are for singly charged ions. Immonium ions are also characteristic fragments that can aid in identification.[5]

Experimental Protocols

Protocol 1: Sample Preparation for LC-MS/MS Analysis of **Phe-Tyr**

This protocol outlines a general procedure for preparing a synthetic **Phe-Tyr** sample for analysis.

- Reconstitution: Dissolve the synthetic **Phe-Tyr** peptide in a solution of 0.1% formic acid in LC-MS grade water to a concentration of 1 mg/mL. Vortex briefly to ensure complete dissolution.
- Dilution: Further dilute the stock solution with 0.1% formic acid in water to a final concentration suitable for your instrument (e.g., 1-10 µg/mL).
- Cleanup (if necessary): If the sample is suspected to contain salts or other non-volatile contaminants, perform a solid-phase extraction (SPE) cleanup using a C18 cartridge.
 - Activate the C18 cartridge with acetonitrile.
 - Equilibrate the cartridge with 0.1% formic acid in water.
 - Load the acidified peptide sample.
 - Wash the cartridge with 0.1% formic acid in water to remove salts.
 - Elute the peptide with a solution of 50-70% acetonitrile and 0.1% formic acid.
 - Dry the eluted sample using a vacuum centrifuge and reconstitute in 0.1% formic acid for injection.[\[6\]](#)

Protocol 2: LC-MS/MS Method for **Phe-Tyr** Fragmentation

This provides a starting point for developing an LC-MS/MS method.

- Liquid Chromatography (LC):
 - Column: C18 reversed-phase column (e.g., 2.1 mm x 50 mm, 1.8 µm particle size).
 - Mobile Phase A: 0.1% formic acid in water.
 - Mobile Phase B: 0.1% formic acid in acetonitrile.

- Gradient: A linear gradient from 5% to 50% Mobile Phase B over 5-10 minutes.
- Flow Rate: 0.3-0.5 mL/min.
- Injection Volume: 1-5 μ L.
- Mass Spectrometry (MS):
 - Ionization Mode: Positive Electrospray Ionization (ESI+).
 - MS1 Scan: Scan for the precursor ion at m/z 329.15.
 - MS/MS Fragmentation:
 - Activation Method: Collision-Induced Dissociation (CID).
 - Isolation Window: 1-2 m/z.
 - Collision Energy: Start with a normalized collision energy of 25-35% and optimize as needed. A stepped or ramped collision energy can also be effective.
 - Detector: Scan the product ions from m/z 50 to 350.

Visual Diagrams

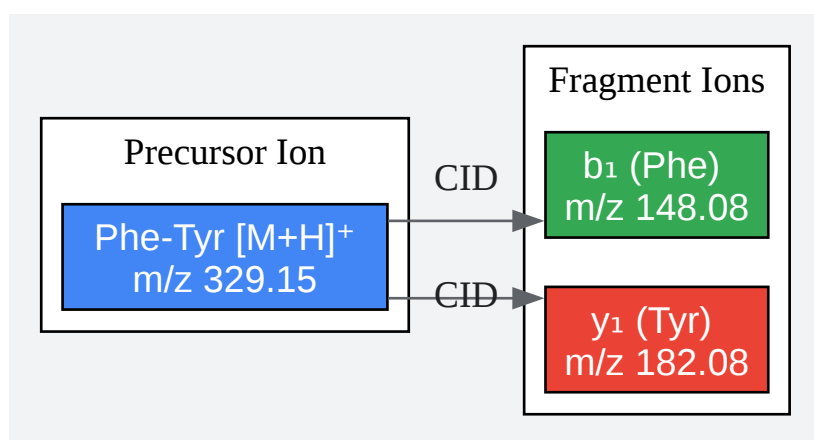

[Click to download full resolution via product page](#)

Caption: CID fragmentation pathway of the **Phe-Tyr** dipeptide.

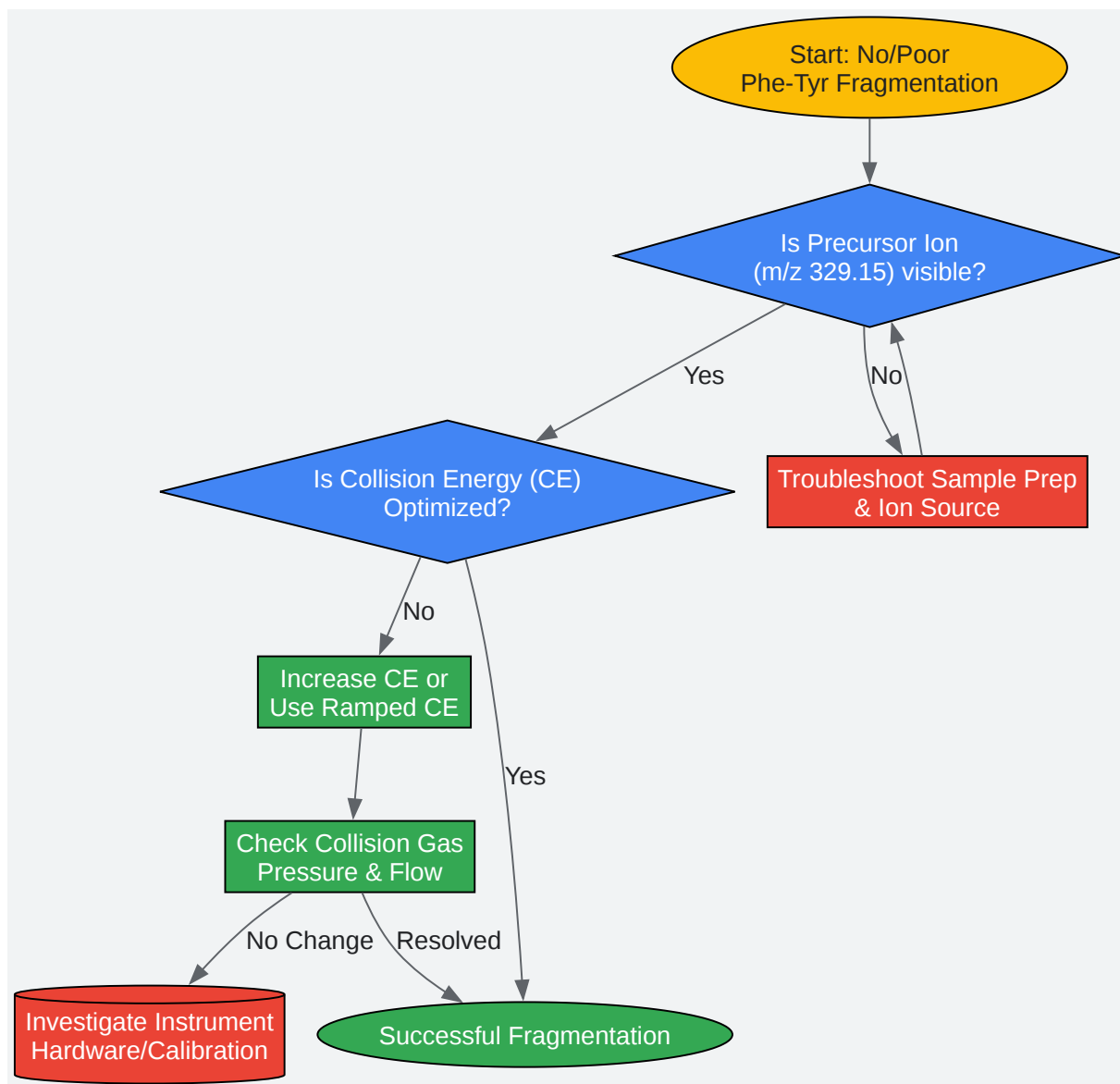

[Click to download full resolution via product page](#)

Caption: Troubleshooting workflow for **Phe-Tyr** fragmentation issues.

Need Custom Synthesis?

BenchChem offers custom synthesis for rare earth carbides and specific isotopic labeling.

Email: info@benchchem.com or [Request Quote Online](#).

References

- [1. Phe-Tyr | C18H20N2O4 | CID 515709 - PubChem \[pubchem.ncbi.nlm.nih.gov\]](#)
- [2. benchchem.com \[benchchem.com\]](#)
- [3. Tips and tricks for successful Mass spec experiments | Proteintech Group \[ptglab.com\]](#)
- [4. researchgate.net \[researchgate.net\]](#)
- [5. alchemistmatt.com \[alchemistmatt.com\]](#)
- [6. benchchem.com \[benchchem.com\]](#)
- To cite this document: BenchChem. [Technical Support Center: Phe-Tyr Mass Spectrometry Fragmentation]. BenchChem, [2026]. [Online PDF]. Available at: [\[https://www.benchchem.com/product/b13640099/docs#technical-support-center-phe-tyr-mass-spectrometry-fragmentation\]](https://www.benchchem.com/product/b13640099/docs#technical-support-center-phe-tyr-mass-spectrometry-fragmentation)

Disclaimer & Data Validity:

The information provided in this document is for Research Use Only (RUO) and is strictly not intended for diagnostic or therapeutic procedures. While BenchChem strives to provide accurate protocols, we make no warranties, express or implied, regarding the fitness of this product for every specific experimental setup.

Technical Support: The protocols provided are for reference purposes. Unsure if this reagent suits your experiment?

Need Industrial/Bulk Grade? [Request Custom Synthesis Quote](#)

BenchChem

Our mission is to be the trusted global source of essential and advanced chemicals, empowering scientists and researchers to drive progress in science and industry.

Contact

Address: 3281 E Guasti Rd

Ontario, CA 91761, United States

Phone: (601) 213-4426

Email: info@benchchem.com

[Contact our Ph.D. Support Team for a compatibility check](#)