

# Comparative Guide: Neuroleptic Potency of Phenothiazine Sulfoxides

**Author:** BenchChem Technical Support Team. **Date:** May 2026

## Compound of Interest

Compound Name: *Trimeprazine sulfoxide*

CAS No.: *10071-07-5*

Cat. No.: *B1364182*

[Get Quote](#)

## Executive Summary

The "Inactivation Rule" and the "Mesoridazine Exception"

In the pharmacodynamics of phenothiazine antipsychotics, sulfoxidation is generally synonymous with inactivation. For the vast majority of agents (e.g., Chlorpromazine), oxidation of the phenothiazine ring sulfur yields a metabolite with negligible affinity for dopamine D2 receptors. This metabolic pathway serves as a primary detoxification route.

However, this guide highlights a critical deviation: Thioridazine. Unlike its congeners, Thioridazine possesses two sulfur atoms. While oxidation of the ring sulfur inactivates the drug, oxidation of the side-chain sulfur produces Mesoridazine, a metabolite that retains full neuroleptic potency and contributes significantly to the parent drug's clinical profile and cardiotoxicity risks.

## Structural & Mechanistic Basis of Potency Loss

To understand why sulfoxides lose potency, one must look beyond simple chemical composition to the 3D conformational changes induced by oxidation.

## The "Butterfly Angle" Hypothesis

The phenothiazine nucleus is not planar; it is folded along the N-S axis, resembling a butterfly. The angle of this fold is the determinant of receptor fit.

- Active State (Sulfide): The angle between the two aryl rings is typically  $139^{\circ}$ – $145^{\circ}$ . This allows the side-chain amine to align precisely with the aspartate residue in the D2 receptor binding pocket.
- Inactive State (Sulfoxide): Oxidation of the ring sulfur creates a sulfoxide (S=O) group. This introduces steric bulk and electronic repulsion, forcing the ring system to flatten or invert to an angle of  $155^{\circ}$ – $160^{\circ}$ .
- Consequence: The side chain folds back over the ring system (the "scorpion tail" conformation), preventing the terminal amine from engaging the receptor.

## Visualization: The Metabolic Divergence

The following diagram illustrates the divergent pathways of Chlorpromazine (inactivation) versus Thioridazine (bioactivation).

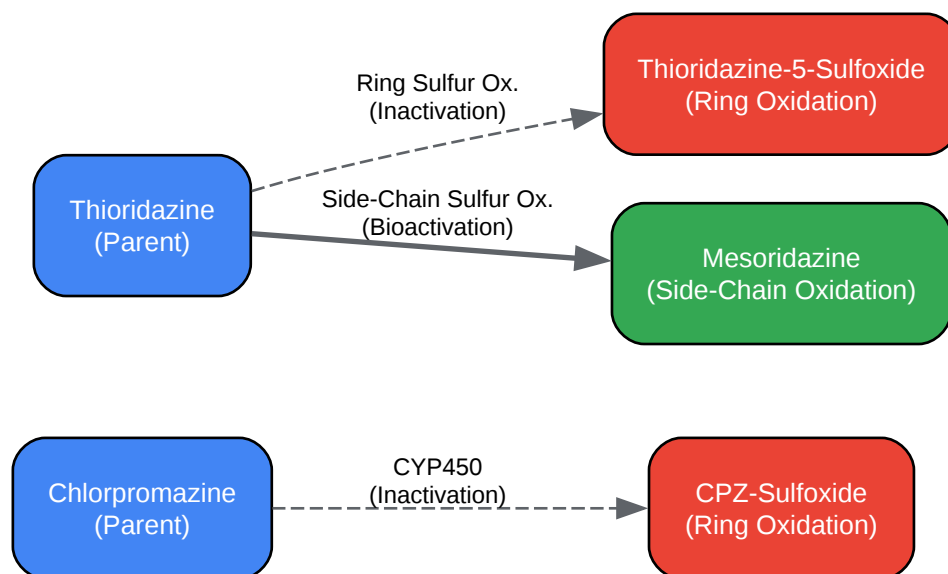

[Click to download full resolution via product page](#)

Figure 1: Metabolic fate of phenothiazines. Note the green node (Mesoridazine) indicating retained potency, contrasting with the red nodes (inactive ring sulfoxides).

## Comparative Pharmacodynamics (Data Analysis)

The following data aggregates receptor binding affinities (K<sub>i</sub>) from radioligand displacement assays ([<sup>3</sup>H]-Spiperone or [<sup>3</sup>H]-Haloperidol).

**Table 1: Receptor Affinity Comparison (Dopamine D2)**

Compound	Metabolic Status	D2 Receptor Affinity (K <sub>i</sub> )	Neuroleptic Potency Ratio (vs Parent)	Clinical Status
Chlorpromazine (CPZ)	Parent	~1.5 – 5.0 nM	1.0 (Reference)	Active Antipsychotic
CPZ-Sulfoxide	Metabolite (Ring)	> 1,000 nM	< 0.01	Inactive
Thioridazine	Parent	~3.0 – 10.0 nM	1.0 (Reference)	Active (Withdrawn*)
Thioridazine-5-Sulfoxide	Metabolite (Ring)	> 1,000 nM	< 0.01	Inactive
Mesoridazine	Metabolite (Side-Chain)	~3.0 – 10.0 nM	1.0 – 1.2	Active (Was marketed separately)
Sulforidazine	Metabolite (Side-Chain Sulfone)	~5.0 – 15.0 nM	0.6 – 0.8	Active

\*Thioridazine was withdrawn from widespread use due to QTc prolongation, partially driven by the accumulation of its active metabolites.

## Key Insight for Drug Development

When developing phenothiazine derivatives or analyzing toxicological data:

- Ring Sulfoxides are markers of clearance, not activity. High levels indicate rapid metabolism but low therapeutic efficacy.
- Side-Chain Sulfoxides (in the Thioridazine class) must be treated as active pharmaceutical ingredients (APIs). They contribute to the therapeutic window and the toxicity profile.

## Experimental Protocols

To verify these potency differences, researchers must employ self-validating binding assays. The following protocol is optimized for differentiating low-affinity sulfoxides from high-affinity parents.

### Protocol A: [3H]-Spiperone Radioligand Binding Assay

Objective: Determine the  $K_i$  (inhibition constant) of the sulfoxide metabolite at D2 receptors.

Reagents:

- Tissue: Rat striatum (rich in D2 receptors) or CHO cells expressing human D2R.
- Radioligand: [3H]-Spiperone (0.2–0.5 nM).
- Buffer: 50 mM Tris-HCl (pH 7.4) containing 120 mM NaCl, 5 mM KCl.
- Displacer: The phenothiazine sulfoxide (test) vs. (+)-Butaclamol (nonspecific binding definition).

Workflow:

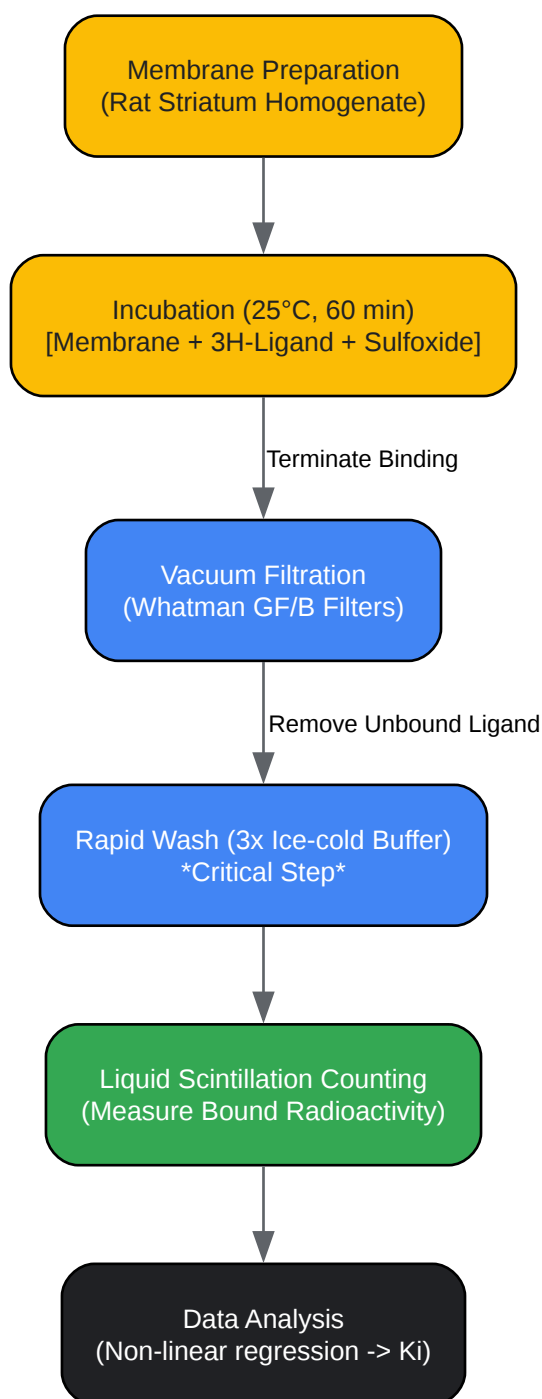

[Click to download full resolution via product page](#)

Figure 2: Workflow for D2 receptor binding assay. The "Wash" step is critical; sulfoxides have rapid dissociation rates (fast off-rates) compared to parents, so washes must be rapid (<10s) to prevent false negatives.

## Protocol B: Electrochemical Synthesis of Sulfoxides

Objective: Generate pure sulfoxide standards for testing, as commercial availability is often limited.

- Method: Controlled potential electrolysis.
- Conditions: Platinum working electrode, acetonitrile solvent, 0.1 M LiClO<sub>4</sub> electrolyte.
- Validation: Monitor the oxidation peak. Phenothiazines exhibit two reversible oxidation waves. The first wave corresponds to the radical cation; addition of water generates the sulfoxide.
- Purification: HPLC is required to separate the sulfoxide from the N-oxide (a minor impurity often formed in chemical oxidation).

## Clinical & Toxicological Implications

### The "Cardiotoxicity Trap"

The persistence of activity in Thioridazine metabolites creates a clinical hazard.

- CYP2D6 Interaction: Thioridazine is metabolized by CYP2D6.<sup>[1]</sup> Poor metabolizers (or patients taking CYP2D6 inhibitors like fluoxetine) accumulate the parent drug.
- Metabolite Accumulation: Extensive metabolizers convert Thioridazine to Mesoridazine. Since Mesoridazine is also cardiotoxic (potassium channel blocker), the total toxic burden remains high regardless of metabolic phenotype.
- Contrast with Chlorpromazine: CPZ metabolism to CPZ-sulfoxide is a true detoxification. The sulfoxide does not block HERG potassium channels to the same extent, nor does it bind D<sub>2</sub> receptors.

## Reference List

- National Center for Biotechnology Information (2025). PubChem Compound Summary for CID 5452, Thioridazine. Retrieved from [\[Link\]](#)
- Snyder, S. H., et al. (1974). Antischizophrenic drugs and brain cholinergic receptors. Archives of General Psychiatry. (Foundational text on receptor binding profiles).

- Noyori, R., et al. (2003). Green oxidation with aqueous hydrogen peroxide.[2] Chemical Communications. (Reference for chemical synthesis of sulfoxides).
- Wojcikowski, J., & Daniel, W. A. (2002). The role of cytochrome P450 isoenzymes in the metabolism of thioridazine. Xenobiotica.[2]
- Seeman, P. (2002). Atypical antipsychotics: Mechanism of action. Canadian Journal of Psychiatry. (Data source for dissociation constants).[3][4]

### Need Custom Synthesis?

BenchChem offers custom synthesis for rare earth carbides and specific isotopic labeling.

Email: [info@benchchem.com](mailto:info@benchchem.com) or [Request Quote Online](#).

## Sources

- [1. Thioridazine | C<sub>21</sub>H<sub>26</sub>N<sub>2</sub>S<sub>2</sub> | CID 5452 - PubChem \[pubchem.ncbi.nlm.nih.gov\]](#)
- [2. chemrxiv.org \[chemrxiv.org\]](#)
- [3. Structure-activity relationships of phenothiazines and related drugs for inhibition of protein kinase C - PubMed \[pubmed.ncbi.nlm.nih.gov\]](#)
- [4. Thioridazine and the neuroleptic radioreceptor assay - PubMed \[pubmed.ncbi.nlm.nih.gov\]](#)
- To cite this document: BenchChem. [Comparative Guide: Neuroleptic Potency of Phenothiazine Sulfoxides]. BenchChem, [2026]. [Online PDF]. Available at: [\[https://www.benchchem.com/product/b1364182/docs#comparative-guide-neuroleptic-potency-of-phenothiazine-sulfoxides\]](https://www.benchchem.com/product/b1364182/docs#comparative-guide-neuroleptic-potency-of-phenothiazine-sulfoxides)

### Disclaimer & Data Validity:

The information provided in this document is for Research Use Only (RUO) and is strictly not intended for diagnostic or therapeutic procedures. While BenchChem strives to provide accurate protocols, we make no warranties, express or implied, regarding the fitness of this product for every specific experimental setup.

**Technical Support:** The protocols provided are for reference purposes. Unsure if this reagent suits your experiment?

**Need Industrial/Bulk Grade?** [Request Custom Synthesis Quote](#)

## BenchChem

Our mission is to be the trusted global source of essential and advanced chemicals, empowering scientists and researchers to drive progress in science and industry.

### Contact

Address: 3281 E Guasti Rd  
Ontario, CA 91761, United States  
Phone: (601) 213-4426  
Email: [info@benchchem.com](mailto:info@benchchem.com)

[Contact our Ph.D. Support Team for a compatibility check](#)