

Comparative Potency Guide: Substituted N-Benzylindole Analogs

Author: BenchChem Technical Support Team. **Date:** May 2026

Compound of Interest

Compound Name: 1-Benzyl-2,3-dimethyl-1H-indole-5-carboxylic acid

CAS No.: 313498-12-3

Cat. No.: B1363186

[Get Quote](#)

Executive Summary

The structural evolution of synthetic cannabinoid receptor agonists (SCRAs) has shifted significantly from the initial aminoalkylindoles (e.g., JWH-018) to N-benzylindole derivatives. This transition is driven by the need to evade legislative controls on alkyl chains and to exploit the hydrophobic pockets of the Cannabinoid Type 1 (CB1) receptor for enhanced binding affinity.

This guide provides a technical comparison of substituted N-benzylindole analogs, specifically focusing on the indole-3-carboxylate and indole-3-carboxamide scaffolds. We analyze the critical role of the N1-benzyl tail modifications (fluorination, steric bulk) on potency (

) and affinity (

).

Key Insight: The substitution of a standard pentyl chain with a 4-fluorobenzyl group (as seen in FUB-PB-22) often results in retained or increased potency while altering metabolic stability,

creating compounds with sub-nanomolar affinity.

Structural Basis & SAR Analysis[1]

The N-benzylindole scaffold consists of three pharmacophoric regions critical for CB1 receptor activation.

The N-Benzyl Tail (N1 Position)

The N1 position of the indole ring is the primary driver of affinity.

- Unsubstituted Benzyl (e.g., BB-22): Provides aromatic π -stacking interactions within the transmembrane helices (TM3/TM6) of the CB1 receptor.
- 4-Fluorobenzyl (e.g., FUB-PB-22): The addition of fluorine at the para position increases lipophilicity and metabolic resistance to oxidation without significantly disrupting the steric fit. This often yields values < 1 nM.
- Steric Constraints: Bulky substitutions (e.g., 2-iodo) can reduce efficacy if they clash with the receptor's hydrophobic channel, whereas para substitutions are generally well-tolerated.

The Linker (C3 Position)

The linker connects the core to the "head" group.

- Ester Linker (e.g., PB-22 class): High potency but susceptible to rapid hydrolysis by plasma esterases (short half-life).
- Amide Linker (e.g., AB-FUBINACA analogs): Greater hydrolytic stability, leading to prolonged in vivo duration.

SAR Visualization

The following diagram illustrates the Structure-Activity Relationship (SAR) logic for this class.

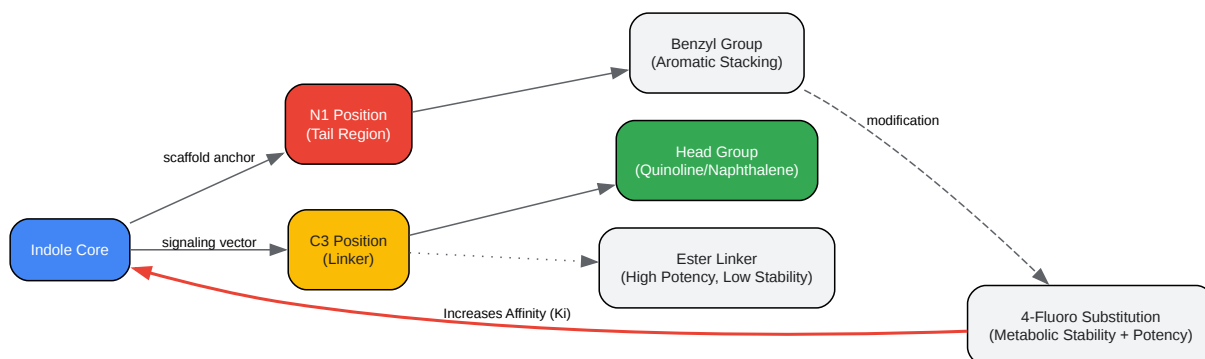

[Click to download full resolution via product page](#)

Figure 1: SAR map highlighting the critical role of the 4-fluorobenzyl tail in enhancing affinity.

Comparative Potency Data

The table below aggregates experimental data comparing N-pentyl baselines with N-benzyl analogs. Note the shift in affinity (

) when the alkyl chain is replaced by a benzyl ring.

Compound	Common Name	N1 Substituent	Linker	CB1 Affinity (nM)	Functional Potency (nM)	Efficacy (%)
PB-22	QUPIC	Pentyl	Ester	0.34 nM	2.9 nM	~217%
5F-PB-22	5F-QUPIC	5-Fluoropentyl	Ester	0.13 nM	3.7 nM	~203%
BB-22	QUCHIC	Benzyl	Ester	0.22 nM	2.9 nM	~215%
FUB-PB-22	-	4-Fluorobenzyl	Ester	0.11 nM	~3.0 nM	High

Data Interpretation:

- **BB-22 vs. PB-22:** Replacing the pentyl chain with a benzyl group (BB-22) improves affinity (drops from 0.34 to 0.22 nM), suggesting favorable interactions in the receptor pocket.
- **Fluorination Effect:** The addition of fluorine (FUB-PB-22) further tightens binding to ~0.11 nM, making it one of the most potent ligands in this class.
- **Efficacy:** All listed compounds act as full agonists (> 100% relative to GTP S basal turnover), posing significant risk of toxicity compared to partial agonists like THC.

Experimental Protocols

To replicate these findings or evaluate new analogs, the following protocols are standardized for high-lipophilicity ligands.

Membrane Preparation (Critical Step)

Why this matters: N-benzylindoles are highly lipophilic. Poor membrane prep results in receptor degradation or "sticky" non-specific binding.

- Harvest: Transfected CHO-hCB1 cells are harvested in ice-cold PBS + 1 mM EDTA.
- Lysis: Homogenize in Buffer A (50 mM Tris-HCl, 5 mM MgCl₂, 2.5 mM EDTA, pH 7.4) using a Polytron homogenizer (3 bursts, 5 sec).
- Centrifugation: Spin at 1,000 x g (10 min, 4°C) to remove debris. Supernatant is saved.
- Pelleting: Spin supernatant at 30,000 x g (40 min, 4°C).
- Resuspension: Resuspend pellet in Buffer A. Repeat centrifugation.
- Storage: Final resuspension in Buffer A + 10% Sucrose (cryoprotectant). Store at -80°C.

Functional Binding Assay

Why this matters: This assay measures the actual activation of the G-protein, distinguishing agonists from antagonists.

Reagents:

- Assay Buffer: 50 mM Tris-HCl (pH 7.4), 3 mM MgCl₂, 0.2 mM EGTA, 100 mM NaCl.
- GDP: 30

M (Essential to suppress basal G-protein activity).

- BSA: 0.1% fatty-acid free (Prevents ligand absorption to plastic).

Workflow:

- Incubation: Mix 5-10

g membrane protein with GDP (30

M) and test compound in 96-well plates.

- Activation: Add 0.05 nM
- . Incubate for 60 min at 30°C.
- Termination: Rapid filtration through GF/B filters pre-soaked in ice-cold water (avoid PEI if background is high, though PEI is standard for radioligand binding).
- Wash: Wash 3x with ice-cold Tris buffer.
- Count: Liquid scintillation counting.

Assay Workflow Diagram

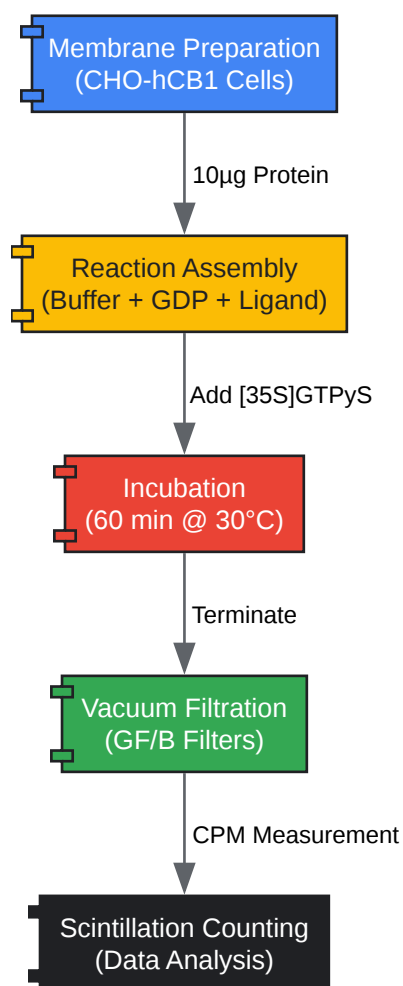

[Click to download full resolution via product page](#)

Figure 2: Step-by-step workflow for the GTP γ S functional assay.

References

- De Luca, M. A., et al. (2015).[1] "Native CB1 receptor affinity, intrinsic activity and accumbens shell dopamine stimulant properties of third generation SPICE/K2 cannabinoids: BB-22, 5F-PB-22, 5F-AKB-48 and STS-135." [1] *Neuropharmacology*. [Link](#)
- Banister, S. D., et al. (2015).[2][3] "Pharmacology of Indole and Indazole Synthetic Cannabinoid Designer Drugs AB-FUBINACA, ADB-FUBINACA, AB-PINACA, ADB-PINACA, 5F-AB-PINACA, 5F-ADB-PINACA, ADBICA, and 5F-ADBICA." *ACS Chemical Neuroscience*. [3] [Link](#)
- Uchiyama, N., et al. (2013). "Two new-type cannabimimetic quinolinyl carboxylates, QUPIC and QUCHIC... identified in illegal products." [3] *Forensic Toxicology*. [Link](#)
- Wohlfarth, A., et al. (2014). "Metabolism of synthetic cannabinoids PB-22 and its 5-fluoro analog, 5F-PB-22, by human hepatocyte incubation and high-resolution mass spectrometry." *Analytical and Bioanalytical Chemistry*. [Link](#)

Need Custom Synthesis?

BenchChem offers custom synthesis for rare earth carbides and specific isotopic labeling.

Email: info@benchchem.com or [Request Quote Online](#).

Sources

- 1. Native CB1 receptor affinity, intrinsic activity and accumbens shell dopamine stimulant properties of third generation SPICE/K2 cannabinoids: BB-22, 5F-PB-22, 5F-AKB-48 and STS-135 - PubMed [pubmed.ncbi.nlm.nih.gov]
- 2. [researchgate.net](https://www.researchgate.net) [[researchgate.net](https://www.researchgate.net)]
- 3. [semanticscholar.org](https://www.semanticscholar.org) [[semanticscholar.org](https://www.semanticscholar.org)]
- To cite this document: BenchChem. [Comparative Potency Guide: Substituted N-Benzyindole Analogs]. BenchChem, [2026]. [Online PDF]. Available at: [<https://www.benchchem.com/product/b1363186/docs#comparative-potency-guide-substituted-n-benzyindole-analogs>]

Disclaimer & Data Validity:

The information provided in this document is for Research Use Only (RUO) and is strictly not intended for diagnostic or therapeutic procedures. While BenchChem strives to provide accurate protocols, we make no warranties, express or implied, regarding the fitness of this product for every specific experimental setup.

Technical Support: The protocols provided are for reference purposes. Unsure if this reagent suits your experiment?

Need Industrial/Bulk Grade? [Request Custom Synthesis Quote](#)

BenchChem

Our mission is to be the trusted global source of essential and advanced chemicals, empowering scientists and researchers to drive progress in science and industry.

Contact

Address: 3281 E Guasti Rd
Ontario, CA 91761, United States
Phone: (601) 213-4426
Email: info@benchchem.com

[Contact our Ph.D. Support Team for a compatibility check](#)