

# Comparative Guide: IR Spectroscopy

## Characterization of 1-(2,2-Dimethoxyethyl)-1H-pyrrole

**Author:** BenchChem Technical Support Team. **Date:** April 2026

### Compound of Interest

Compound Name: 1-(2,2-Dimethoxyethyl)-1H-pyrrole

CAS No.: 93217-61-9

Cat. No.: B1363663

[Get Quote](#)

## Executive Summary & Technical Rationale

This guide provides a definitive spectroscopic framework for validating **1-(2,2-Dimethoxyethyl)-1H-pyrrole** (CAS: 1523-06-4). Unlike standard spectral lists, this document focuses on differential diagnosis—using Infrared (IR) Spectroscopy not just to confirm identity, but to actively rule out critical synthesis failures: incomplete alkylation (presence of pyrrole) and acetal hydrolysis (presence of aldehyde).

**The Core Challenge:** The target molecule combines an electron-rich aromatic heterocycle (pyrrole) with an acid-labile protecting group (dimethyl acetal). A "correct" spectrum must simultaneously prove the integrity of the acetal (C-O-C bands) and the substitution of the pyrrole nitrogen (absence of N-H), while ensuring no carbonyl (C=O) artifacts are present.

## Structural & Vibrational Logic

To interpret the spectrum accurately, we must deconstruct the molecule into its independent vibrational domains.

## Molecular Vibrational Domains

The molecule consists of two distinct spectroscopic zones:

- The Aromatic Head (Pyrrole Ring): Dominated by C=C stretches and ring breathing modes.
- The Aliphatic Tail (Dimethoxyethyl chain): Dominated by C-H stretches (methoxy/methylene) and strong ether C-O linkages.

## Visualization of Vibrational Modes

The following diagram maps the critical functional groups to their expected IR signals.

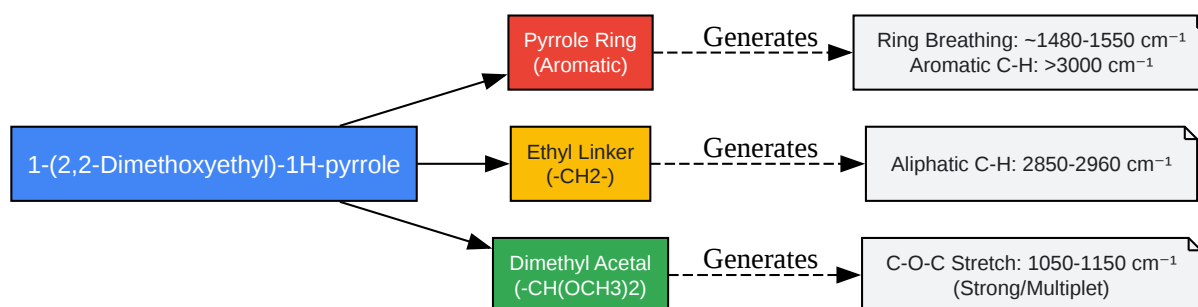

[Click to download full resolution via product page](#)

Figure 1: Vibrational mapping of the target molecule. Note the distinct separation between the aromatic "Head" and aliphatic "Tail" signals.

## Comparative Spectral Analysis

This section serves as the primary validation tool. You must compare your sample's spectrum against these three specific benchmarks.

## The "Golden" Bands (Target Molecule)

These bands must be present for a positive identification.

Functional Group	Mode of Vibration	Wavenumber (cm <sup>-1</sup> )	Intensity	Diagnostic Note
Pyrrole C-H	Stretching (Ar-H)	3100 – 3130	Weak	Distinctive "shoulder" above 3000. Confirms aromaticity.
Alkyl C-H	Stretching (C-H)	2830 – 2960	Medium	Multiple peaks from -CH <sub>2</sub> - and -OCH <sub>3</sub> . The 2830 band is often specific to methoxy groups.
Pyrrole Ring	C=C / C=N Stretch	1480 – 1550	Med-Strong	Often appears as a doublet. Confirms the heterocyclic core.
Acetal C-O	C-O-C Asym. Stretch	1100 – 1150	Very Strong	The "fingerprint" of the acetal. Usually the strongest peak in the spectrum.
Acetal C-O	C-O-C Sym. Stretch	1050 – 1090	Strong	Appears alongside the asymmetric stretch.

## The "Red Flag" Bands (Impurity Markers)

These bands must be absent. Their presence indicates specific failure modes.

Impurity Source	Marker Band	Wavenumber (cm <sup>-1</sup> )	Diagnosis	Corrective Action
Pyrrole (SM)	N-H Stretch	3200 – 3400	Broad, Strong	Incomplete Alkylation. The reaction did not go to completion.
Aldehyde	C=O Stretch	1710 – 1740	Sharp, Strong	Hydrolysis. The acetal has degraded (likely due to acidic workup or wet solvents).
Water	O-H Stretch	3200 – 3600	Broad	Wet Sample. Acetal is at risk of hydrolysis. Dry immediately.

## Experimental Protocol: The "Self-Validating" Workflow

To ensure data integrity (E-E-A-T), follow this decision-tree protocol. This method forces you to validate the sample quality before accepting the structural data.

### Sample Preparation (Liquid Film)

- Technique: ATR (Attenuated Total Reflectance) is preferred over transmission cells (NaCl/KBr) to avoid moisture absorption which degrades the acetal.
- Prism: Diamond or ZnSe.
- Pre-Check: Ensure the ATR crystal is neutral pH. Acidic cleaning residues will hydrolyze the acetal during measurement, creating a false C=O peak.

### The Decision Logic Pathway

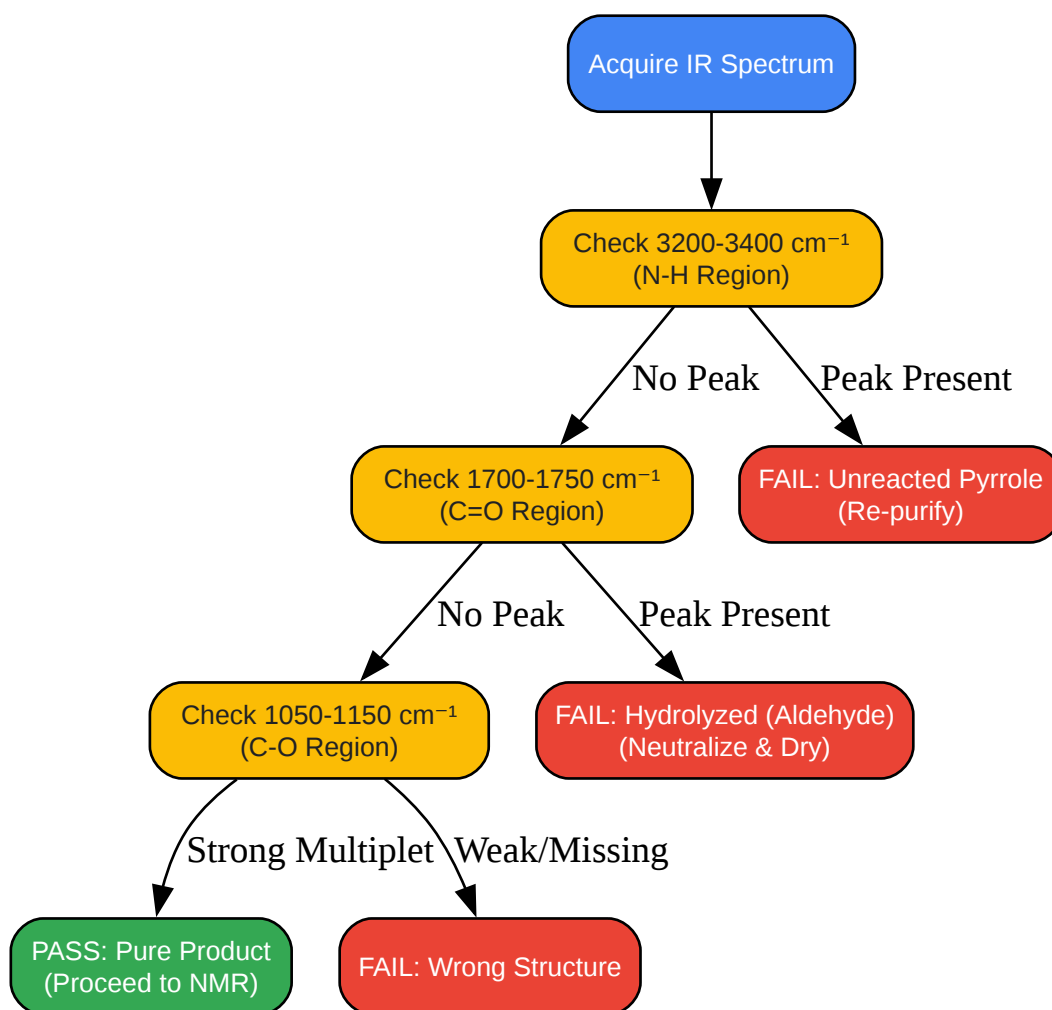

[Click to download full resolution via product page](#)

Figure 2: Quality Control Decision Matrix. This logic gate ensures no compromised material moves to the next stage of development.

## Mechanistic Insight: Why These Bands Matter

### The N-H Disappearance (The Substitution Proof)

In the starting material (1H-pyrrole), the N-H bond is highly polar and exhibits a strong, broad absorption at  $\sim 3400\text{ cm}^{-1}$ . The alkylation at the nitrogen position removes this bond entirely.

- Scientific Insight: If you see a weak band here, it may be water. Check the  $1640\text{ cm}^{-1}$  region (H-O-H bending). If 1640 is absent but 3400 is present, it is residual pyrrole.

## The Acetal C-O "Masking"

The dimethyl acetal group introduces strong C-O stretching vibrations. In many N-alkyl pyrroles, the fingerprint region is relatively clean. However, for **1-(2,2-Dimethoxyethyl)-1H-pyrrole**, the 1000-1200  $\text{cm}^{-1}$  region becomes complex and intense.

- Caution: Do not confuse these strong C-O bands with C-N stretches (which are typically weaker and appear around 1200-1300  $\text{cm}^{-1}$ ).

## Stability Monitoring

The conversion of the acetal (C-O-C) to the aldehyde (C=O) is thermodynamically favorable in the presence of water and acid.

- Reaction:
- Spectral Consequence: The "Very Strong" band at 1100  $\text{cm}^{-1}$  diminishes, and a new "Sharp" band at 1720  $\text{cm}^{-1}$  appears. This is the most sensitive method for monitoring shelf-life stability.

## References

- NIST Chemistry WebBook. Pyrrole IR Spectrum. National Institute of Standards and Technology.[1] [\[Link\]](#)
- NIST Chemistry WebBook. Benzaldehyde dimethyl acetal IR Spectrum (Analog for Acetal Group). National Institute of Standards and Technology.[1] [\[Link\]](#)
- Silverstein, R. M., Webster, F. X., & Kiemle, D. J. Spectrometric Identification of Organic Compounds. (Standard text for general group frequency assignments).

### *Need Custom Synthesis?*

*BenchChem offers custom synthesis for rare earth carbides and specific isotopic labeling.*

*Email: [info@benchchem.com](mailto:info@benchchem.com) or [Request Quote Online](#).*

## Sources

- 1. 1H-Pyrrole, 2,5-dimethyl- [[webbook.nist.gov](http://webbook.nist.gov)]
- To cite this document: BenchChem. [Comparative Guide: IR Spectroscopy Characterization of 1-(2,2-Dimethoxyethyl)-1H-pyrrole]. BenchChem, [2026]. [Online PDF]. Available at: [<https://www.benchchem.com/product/b1363663/docs#comparative-guide-ir-spectroscopy-characterization-of-1-2-2-dimethoxyethyl-1h-pyrrole>]

---

### Disclaimer & Data Validity:

The information provided in this document is for Research Use Only (RUO) and is strictly not intended for diagnostic or therapeutic procedures. While BenchChem strives to provide accurate protocols, we make no warranties, express or implied, regarding the fitness of this product for every specific experimental setup.

**Technical Support:** The protocols provided are for reference purposes. Unsure if this reagent suits your experiment?

**Need Industrial/Bulk Grade?** [Request Custom Synthesis Quote](#)

## BenchChem

Our mission is to be the trusted global source of essential and advanced chemicals, empowering scientists and researchers to drive progress in science and industry.

### Contact

Address: 3281 E Guasti Rd  
Ontario, CA 91761, United States  
Phone: (601) 213-4426  
Email: [info@benchchem.com](mailto:info@benchchem.com)

[Contact our Ph.D. Support Team for a compatibility check](#)