

comparative study of synthesis methods for tertiary cyclopropyl alcohols

Author: BenchChem Technical Support Team. **Date:** May 2026

Compound of Interest

Compound Name: *2-(1-Methylcyclopropyl)propan-2-ol*

Cat. No.: B13614758

[Get Quote](#)

Comparative Study: Synthesis Methods for Tertiary Cyclopropyl Alcohols

Executive Summary

The tertiary cyclopropyl alcohol motif—a hydroxyl group bonded to a quaternary carbon bearing a cyclopropyl ring—is a privileged pharmacophore in modern drug design (e.g., in kinase inhibitors and antiviral agents). It offers unique conformational restriction and metabolic stability compared to isopropyl or tert-butyl bioisosteres.

This guide objectively compares the three dominant synthetic methodologies for accessing this scaffold:

- The Kulinkovich Reaction: Titanium-catalyzed reductive coupling of esters.
- Asymmetric Simmons-Smith Cyclopropanation: Zinc-mediated methylene transfer to tertiary allylic alcohols.
- Nucleophilic Addition: Grignard/Lithium addition to cyclopropyl ketones.

Verdict: While Nucleophilic Addition remains the standard for simple, achiral substrates, the Kulinkovich Reaction offers superior atom economy and step-efficiency for generating 1-substituted cyclopropanols directly from esters. The Simmons-Smith protocol is the method of choice when high enantioselectivity is required, utilizing the hydroxyl group as a stereodirecting anchor.

Methodology Analysis

Method A: The Kulinkovich Reaction (Titanium-Catalyzed)

Best for: Rapid access to 1-substituted cyclopropanols from esters.

This reaction revolutionized cyclopropanol synthesis by allowing the transformation of carboxylic esters into cyclopropanols in a single step using a Grignard reagent (typically EtMgBr) and a catalytic amount of Titanium(IV) isopropoxide.

Mechanism & Causality

The reaction does not proceed via simple nucleophilic attack. Instead, it involves a "ligand exchange" mechanism where the low-valent titanium species forms a titanacyclopropane intermediate. This acts as a 1,2-dicarbonyl equivalent, attacking the ester carbonyl twice.^[1]



[Click to download full resolution via product page](#)

Figure 1: Catalytic cycle of the Kulinkovich reaction showing the critical titanacyclopropane intermediate.^[1]

Protocol Highlights

- Catalyst Loading: 5–10 mol% Ti(OiPr)₄ is standard. Higher loading (up to 1 equiv) may be needed for hindered esters.

- Reagent Addition: Slow addition of EtMgBr is critical to maintain the catalytic cycle and prevent "swamping" the active Ti species.
- Self-Validating Step: The evolution of ethane gas is a visual indicator of the active catalyst formation. Cessation of gas evolution often signals catalyst deactivation.

Method B: Asymmetric Simmons-Smith Cyclopropanation

Best for: Enantioselective synthesis starting from tertiary allylic alcohols.

When a tertiary allylic alcohol is available (e.g., from vinyl Grignard addition to a ketone), the Simmons-Smith reaction ($\text{Zn}/\text{CH}_2\text{I}_2$) utilizes the hydroxyl group to coordinate the zinc carbenoid, directing the cyclopropanation to the same face of the alkene.

Mechanism & Stereocontrol

The Charette modification uses a chiral dioxaborolane ligand to achieve high enantiomeric excess (ee). The zinc reagent coordinates to the alcohol oxygen, forming a "butterfly" transition state that delivers the methylene group stereospecifically.

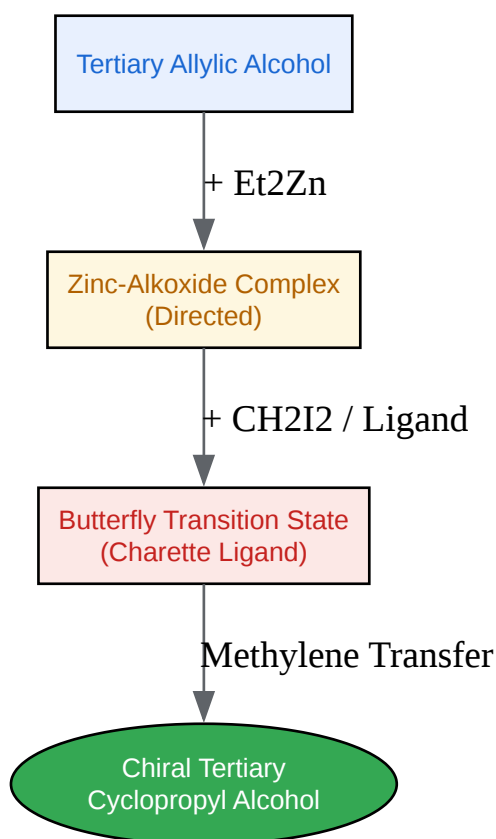

[Click to download full resolution via product page](#)

Figure 2: Directed stereoselective cyclopropanation via Zinc carbenoid.

Protocol Highlights

- Reagent Quality: Diiodomethane (CH_2I_2) must be copper-stabilized or freshly distilled; iodine impurities inhibit the reaction.
- Stoichiometry: Requires excess reagents (2–3 equiv of $\text{Et}_2\text{Zn}/\text{CH}_2\text{I}_2$) due to the steric bulk of tertiary alcohols.
- Safety: Organozincs are pyrophoric. CH_2I_2 is toxic.^{[2][3][4]} All transfers must occur under inert atmosphere (Ar/N_2).

Method C: Nucleophilic Addition to Cyclopropyl Ketones

Best for: Simple, achiral substrates and large-scale manufacturing.

This is the classical route: a cyclopropyl ketone reacts with an organolithium or Grignard reagent. While conceptually simple, it faces challenges with "abnormal" ring opening (Walsh-type) under acidic quench conditions or if the cyclopropyl ring stabilizes a carbocation intermediate.

- Constraint: The starting material (cyclopropyl ketone) must be available.
- Risk: Steric hindrance at the carbonyl can lead to enolization (proton transfer) rather than addition, reducing yield.

Comparative Performance Metrics

The following data summarizes the performance of these methods on a benchmark substrate (e.g., synthesis of 1-phenylcyclopropanol or similar derivatives).

Metric	Kulinkovich Reaction	Simmons-Smith (Directed)	Nucleophilic Addition
Starting Material	Benzoate Ester	-Methylstyrene (via Allylic Alc)	Cyclopropyl Phenyl Ketone
Step Count	1 (Direct)	2 (Ketone Vinyl cPr)	1 (Direct)
Yield (Typical)	75–90%	60–85% (2 steps)	80–95%
Atom Economy	Moderate (Ethane waste)	Poor (ZnI ₂ stoichiometric waste)	High
Stereocontrol	Low (unless chiral ligands used)	High (>90% ee)	N/A (Achiral) or Substrate-controlled
Scalability	High (Flow chem compatible)	Low (Exotherms, Zinc waste)	High
Cost Driver	Ti(OiPr) ₄ (Low)	CH ₂ I ₂ (High)	Cyclopropyl Ketone availability

Decision Matrix for Process Selection

Use this logic flow to select the optimal synthesis route for your specific drug candidate.

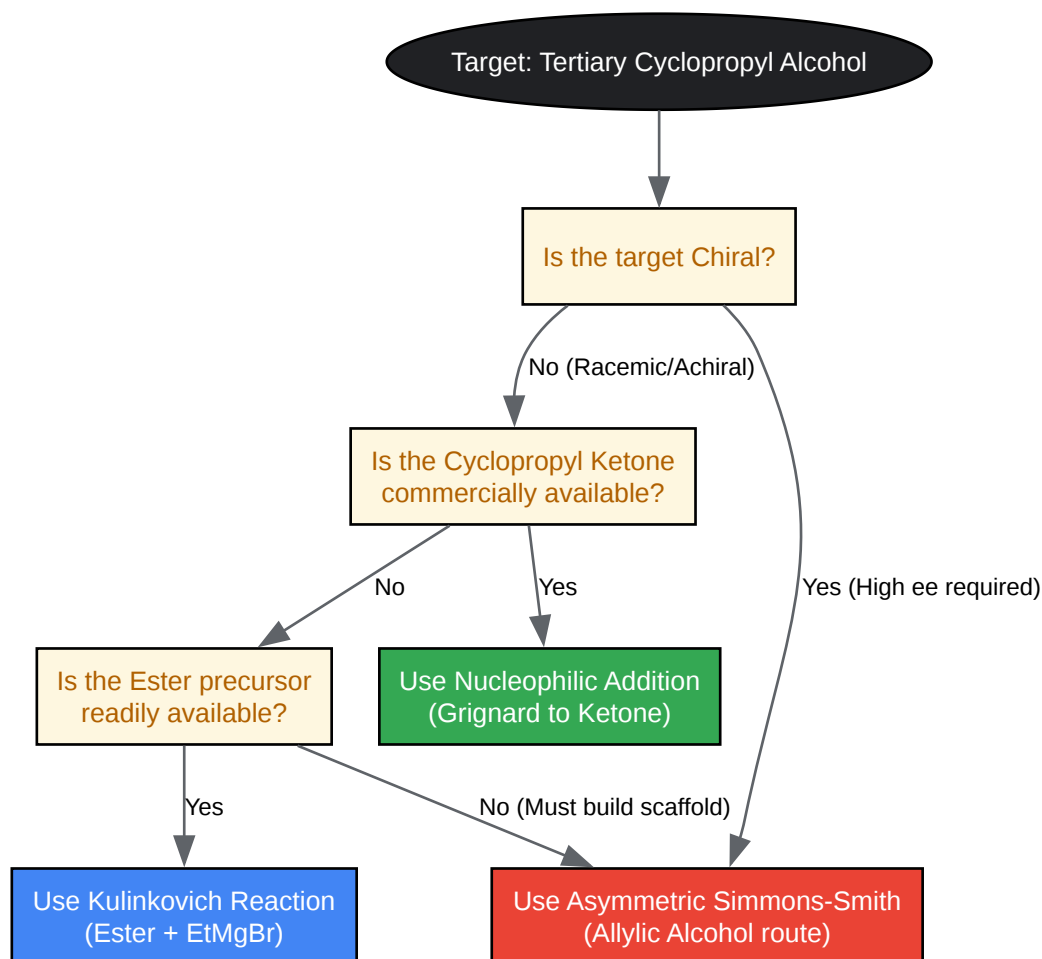

[Click to download full resolution via product page](#)

Figure 3: Strategic workflow for selecting the synthesis method.

Experimental Protocols

Protocol A: Kulinkovich Synthesis of 1-Phenylcyclopropanol

Reference: Adapted from Kulinkovich et al. (1989) and Org. Synth. 2012.

- Setup: Flame-dry a 500 mL 3-neck flask equipped with a pressure-equalizing addition funnel and reflux condenser. Flush with Argon.

- Charge: Add Methyl Benzoate (50 mmol) and $\text{Ti}(\text{OiPr})_4$ (2.5 mmol, 5 mol%) to anhydrous Et_2O (100 mL). Cool to 0°C .
- Addition: Add EtMgBr (3.0 M in Et_2O , 110 mmol, 2.2 equiv) dropwise over 1 hour.
 - Observation: The solution will turn from colorless to yellow, then dark brown/black. Gas evolution (ethane) will be vigorous—ensure proper venting.
- Reaction: Remove ice bath and stir at room temperature for 1 hour.
- Quench: Cool to 0°C . Carefully add H_2O (10 mL), then 10% aqueous H_2SO_4 (50 mL) until the precipitate dissolves and two clear phases appear.
- Workup: Extract with Et_2O (3x). Wash combined organics with NaHCO_3 and Brine. Dry over MgSO_4 .
- Purification: Silica gel chromatography (Hexanes/ EtOAc).

Protocol B: Charette Asymmetric Cyclopropanation

Reference: Charette, A. B. et al. *J. Am. Chem. Soc.* 1998.

- Pre-complexation: To a solution of the Tertiary Allylic Alcohol (1.0 equiv) in CH_2Cl_2 at -20°C , add Et_2Zn (2.0 equiv). Stir for 10 min.
- Ligand Addition: Add the Charette Dioxaborolane Ligand (1.1 equiv). Stir for 1 hour to form the chiral zinc alkoxide.
- Cyclopropanation: Add CH_2I_2 (2.0 equiv) dropwise. Maintain temperature at -10°C to 0°C .
- Completion: Monitor by TLC. Upon completion, quench with saturated NH_4Cl .
- Note: The high stereoselectivity (>90% ee) relies on the strict exclusion of moisture which can hydrolyze the zinc-ligand complex.

References

- Kulinkovich, O. G., et al. (1989). "Reaction of Ethyl Magnesium Bromide with Carboxylic Esters in the Presence of Titanium Alkoxides." Zhurnal Organicheskoi Khimii.
- Charette, A. B., & Marcoux, J. F. (1998). "The Simmons-Smith Reaction: Stereoselective Synthesis of Cyclopropanes." Journal of the American Chemical Society.
- Simmons, H. E., & Smith, R. D. (1958). "A New Synthesis of Cyclopropanes." Journal of the American Chemical Society.
- Cha, J. K., & Kulinkovich, O. G. (2012). "The Kulinkovich Cyclopropanation of Carboxylic Acid Derivatives." Organic Reactions.[5][6][7]
- Wurts, J., et al. (2014). "Nucleophilic Addition to Cyclopropyl Ketones: Controlling Factors." Journal of Organic Chemistry.

Need Custom Synthesis?

BenchChem offers custom synthesis for rare earth carbides and specific isotopic labeling.

Email: info@benchchem.com or [Request Quote Online](#).

Sources

- [1. Kulinkovich Reaction \[organic-chemistry.org\]](#)
- [2. chemos.de \[chemos.de\]](#)
- [3. chemos.de \[chemos.de\]](#)
- [4. tcichemicals.com \[tcichemicals.com\]](#)
- [5. bilder.buecher.de \[bilder.buecher.de\]](#)
- [6. Simmons–Smith reaction - Wikipedia \[en.wikipedia.org\]](#)
- [7. Thieme E-Journals - Synthesis / Abstract \[thieme-connect.com\]](#)
- To cite this document: BenchChem. [comparative study of synthesis methods for tertiary cyclopropyl alcohols]. BenchChem, [2026]. [Online PDF]. Available at: [\[https://www.benchchem.com/product/b13614758/docs#comparative-study-of-synthesis-methods-for-tertiary-cyclopropyl-alcohols\]](https://www.benchchem.com/product/b13614758/docs#comparative-study-of-synthesis-methods-for-tertiary-cyclopropyl-alcohols)

Disclaimer & Data Validity:

The information provided in this document is for Research Use Only (RUO) and is strictly not intended for diagnostic or therapeutic procedures. While BenchChem strives to provide accurate protocols, we make no warranties, express or implied, regarding the fitness of this product for every specific experimental setup.

Technical Support: The protocols provided are for reference purposes. Unsure if this reagent suits your experiment?

Need Industrial/Bulk Grade? [Request Custom Synthesis Quote](#)

BenchChem

Our mission is to be the trusted global source of essential and advanced chemicals, empowering scientists and researchers to drive progress in science and industry.

Contact

Address: 3281 E Guasti Rd
Ontario, CA 91761, United States
Phone: (601) 213-4426
Email: info@benchchem.com

[Contact our Ph.D. Support Team for a compatibility check](#)