

# Cross-validation of synthesis pathways for fluorinated hydroxyacetic acids

**Author:** BenchChem Technical Support Team. **Date:** May 2026

## Compound of Interest

Compound Name: *2-(3-Fluoro-4-methoxyphenyl)-2-hydroxyacetic acid*

Cat. No.: *B13606254*

[Get Quote](#)

## Comparative Synthesis Guide: Fluorinated Hydroxyacetic Acid Derivatives

### Executive Summary: The Strategic Scaffold

Fluorinated hydroxyacetic acid derivatives—specifically 3,3,3-trifluoro-2-hydroxypropanoic acid (Trifluorolactic acid) and

-difluoro-

-hydroxy esters—represent a critical class of bioisosteres in medicinal chemistry. The introduction of fluorine at the

-position to a hydroxyl group significantly lowers the pKa of the alcohol (increasing hydrogen bond donor capability) and blocks metabolic oxidation, enhancing the pharmacokinetics of drug candidates.

This guide cross-validates the three primary synthetic pathways for generating these scaffolds, focusing on enantiopurity, scalability, and industrial viability.[1]

## Comparative Analysis of Synthetic Routes

### Route A: Enantioselective Reduction of Fluorinated Keto-Esters

Status: The Industrial Gold Standard for Chiral

-Hydroxy Acids

This route relies on the asymmetric reduction of ethyl trifluoropyruvate.<sup>[1]</sup> It is the preferred method for generating chiral 3,3,3-trifluoro-2-hydroxypropanoic acid derivatives due to the availability of highly efficient chiral catalysts.

- Mechanism: Hydride transfer to the electron-deficient ketone, controlled by a chiral ligand (e.g., BINAP, Box) or enzyme (KREDs).<sup>[1]</sup>
- Key Advantage: extremely high enantiomeric excess (ee > 99%) and atom economy.<sup>[1]</sup>
- Limitation: Cost of chiral catalysts and the high cost of the trifluoropyruvate starting material.

### Route B: The Reformatsky Reaction (Gem-Difluoro Species)

Status: The Versatile "Building Block" Approach

For synthesizing

-difluoro-

-hydroxy esters, the Reformatsky reaction using ethyl bromodifluoroacetate is the dominant methodology. Unlike standard Grignard reagents, the organozinc intermediate is tolerant of ester groups, allowing for direct coupling with aldehydes or ketones.<sup>[1]</sup>

- Mechanism: Oxidative insertion of activated Zinc into the C-Br bond, followed by nucleophilic attack on the carbonyl.
- Key Advantage: Modular synthesis; allows rapid library generation by varying the electrophile (aldehyde/ketone).<sup>[1]</sup>

- Limitation: Stoichiometric metal waste (Zn) and sensitivity to moisture; initiation can be capricious on large scales.[1]

## Route C: Nucleophilic Trifluoromethylation (Ruppert-Prakash)

Status: The Tertiary Alcohol Specialist

When the target is a tertiary alcohol (e.g., from a ketone precursor), direct nucleophilic trifluoromethylation using TMS-CF

(Ruppert-Prakash reagent) is often superior to reduction methods.

- Mechanism: Fluoride-initiated release of the "CF" equivalent, which attacks the carbonyl.
- Key Advantage: Access to sterically congested quaternary centers that are difficult to form via reduction.[1]
- Limitation: TMS-CF is expensive; requires strict anhydrous conditions.[1]

## Cross-Validation Metrics

The following table synthesizes experimental data to guide route selection.

Metric	Route A: Enantioselective Reduction	Route B: Reformatsky (Zn- mediated)	Route C: Nucleophilic CF
Target Scaffold	-CF - -hydroxy acids	-difluoro- -hydroxy esters	Tertiary -CF alcohols
Typical Yield	85–98%	60–85%	70–95%
Enantioselectivity	>98% ee (Catalyst dependent)	Low (Racemic) unless chiral aux. used	N/A (Racemic) or requires chiral catalyst
Scalability	High (Kg scale proven)	Moderate (Exotherm control required)	Moderate (Reagent cost limits scale)
Atom Economy	High	Low (Stoichiometric Zn waste)	Moderate (Silyl group waste)
Cost Driver	Chiral Catalyst / Ligand	Ethyl bromodifluoroacetate	TMS-CF Reagent

## Detailed Experimental Protocols

### Protocol 1: Enantioselective Synthesis of (R)-3,3,3-Trifluoro-2-hydroxypropionate

Based on Ruthenium-catalyzed transfer hydrogenation.

Reagents:

- Ethyl 3,3,3-trifluoropyruvate (10 mmol)[1]
- RuCl(p-cymene)[(R,R)-TsDPEN] (0.5 mol%)[1]
- Formic acid / Triethylamine (5:2 azeotrope)[1]
- Dichloromethane (DCM)

## Step-by-Step Workflow:

- Catalyst Prep: In a flame-dried Schlenk flask, dissolve the Ru-catalyst (32 mg) in dry DCM (10 mL).
- Addition: Add the Formic acid/TEA mixture (2.0 eq of hydride source) via syringe. Stir for 10 min at ambient temperature.
- Reaction: Cool the mixture to 0°C. Add Ethyl 3,3,3-trifluoropyruvate (1.70 g, 10 mmol) dropwise over 15 minutes. Critical: Control exotherm to maintain enantioselectivity.
- Monitoring: Stir at 0°C for 4–6 hours. Monitor consumption by TLC (20% EtOAc/Hexane) or <sup>1</sup>F NMR (shift from -72 ppm ketone to -75 ppm alcohol).<sup>[1]</sup>
- Workup: Quench with water (20 mL). Extract aqueous layer with DCM (3 x 15 mL). Wash combined organics with saturated NaHCO<sub>3</sub> and brine.<sup>[1]</sup>
- Purification: Dry over Na<sub>2</sub>SO<sub>4</sub>, concentrate, and purify via flash chromatography or vacuum distillation.
- Validation: Check ee% via Chiral HPLC (Chiralcel OD-H column).

## Protocol 2: Reformatsky Synthesis of Ethyl 2,2-difluoro-3-hydroxy-3-phenylpropanoate

## Reagents:

- Benzaldehyde (10 mmol)<sup>[1]</sup>
- Ethyl bromodifluoroacetate (12 mmol)<sup>[1]</sup>
- Zinc dust (activated, 15 mmol)<sup>[1]</sup>

- THF (anhydrous)[1]

#### Step-by-Step Workflow:

- Activation: Activate Zinc dust by washing with dilute HCl, water, ethanol, and ether, then drying under vacuum at 100°C.[1]
- Initiation: Suspend activated Zn (0.98 g) in THF (20 mL). Add TMSCl (0.1 mL) as an activator.[1] Heat to reflux briefly.[1]
- Addition: Add a solution of Ethyl bromodifluoroacetate (2.44 g) and Benzaldehyde (1.06 g) in THF dropwise to the refluxing suspension. Note: The reaction should self-sustain reflux once initiated.
- Completion: After addition, reflux for an additional 2 hours.
- Quench: Cool to 0°C and quench with 1M HCl (careful: gas evolution).
- Isolation: Extract with diethyl ether. Wash with NaHCO<sub>3</sub> solution. Dry and concentrate.
- Purification: Silica gel chromatography (Hexane/EtOAc gradient).

## Visualizations of Pathways

### Diagram 1: Strategic Decision Tree for Synthesis

This diagram illustrates the logical flow for selecting the correct synthetic route based on the target substrate structure.

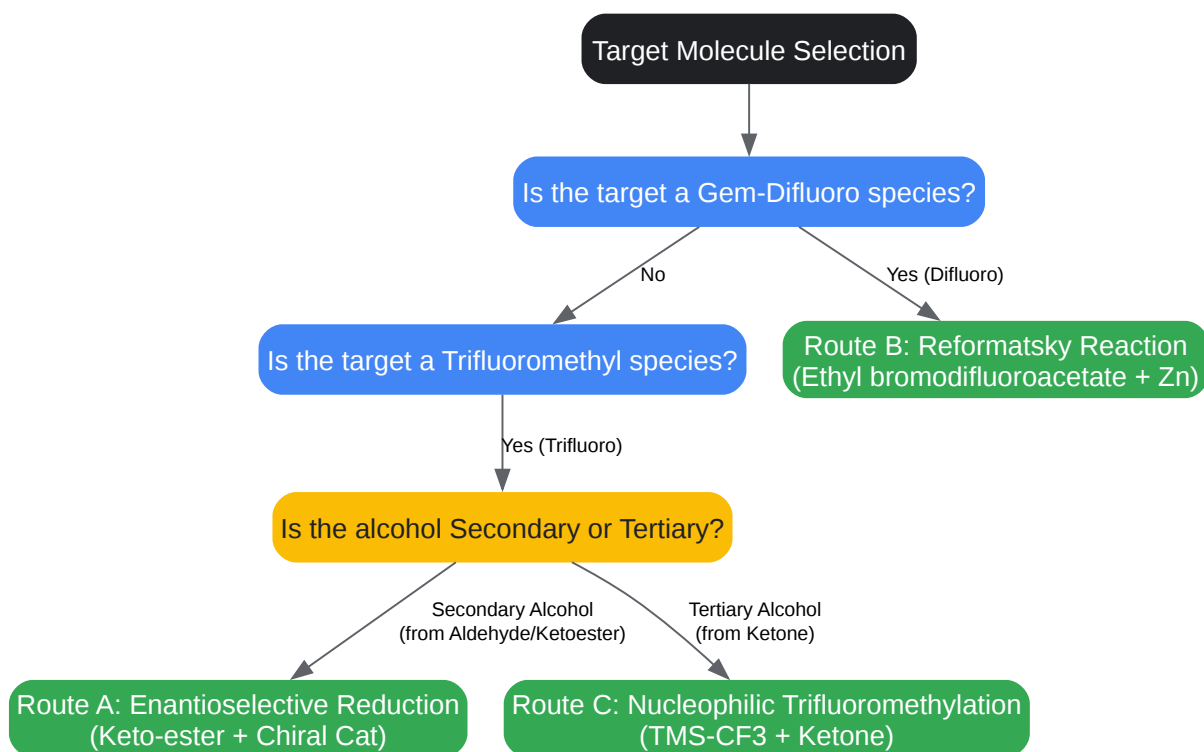

[Click to download full resolution via product page](#)

Caption: Decision matrix for selecting the optimal synthetic pathway based on fluorine substitution pattern and alcohol class.

## Diagram 2: Mechanistic Comparison (Reduction vs. Reformatsky)

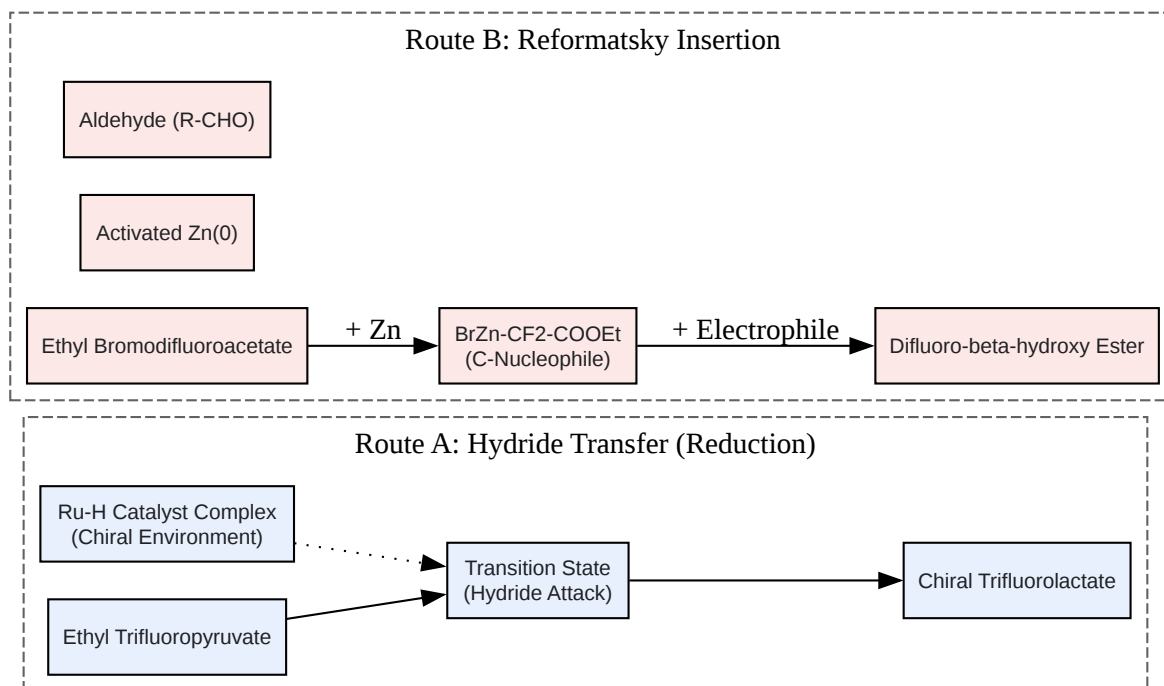

[Click to download full resolution via product page](#)

Caption: Mechanistic contrast showing chiral hydride transfer (Route A) versus organometallic insertion (Route B).

## References

- Sato, K., et al. (2006).[1] "Trifluoromethylation at the  
-Position of  
-Unsaturated Ketones." Organic Syntheses, 83, 177.[1][2] [Link](#)
- Ando, A., et al. (2012).[1] "Synthesis of  
-fluoro-  
-hydroxy esters by an enantioselective Reformatsky-type reaction." Chemical Communications.[1] [Link](#)

- BenchChem Technical Support. (2025). "One-Pot Synthesis of -Hydroxy Esters via the Reformatsky Reaction." BenchChem Application Notes. [Link](#)
- Virmani, A., et al. (2024).[1][3][4] "Deoxyfluorination with superacids – synthesis and characterization of protonated -fluorohydroxyacetic acid." RSC Advances, 14, 31517-31523.[1][3] [Link](#)
- Shaw, N.M., et al. (2003).[1] "Enantioselective preparation of 3,3,3-trifluoro-2-hydroxy-2-methylpropionic acid." Biocatalysis and Biotransformation. [Link](#)[1]

### Need Custom Synthesis?

BenchChem offers custom synthesis for rare earth carbides and specific isotopic labeling.

Email: [info@benchchem.com](mailto:info@benchchem.com) or [Request Quote Online](#).

## Sources

- 1. Trifluoroacetic acid - Wikipedia [[en.wikipedia.org](https://en.wikipedia.org)]
- 2. Organic Syntheses Procedure [[orgsyn.org](https://orgsyn.org)]
- 3. Deoxyfluorination with superacids – synthesis and characterization of protonated  $\alpha$ -fluorohydroxyacetic acid - RSC Advances (RSC Publishing) [[pubs.rsc.org](https://pubs.rsc.org)]
- 4. Deoxyfluorination with superacids – synthesis and characterization of protonated  $\alpha$ -fluorohydroxyacetic acid - PMC [[pmc.ncbi.nlm.nih.gov](https://pubmed.ncbi.nlm.nih.gov)]
- To cite this document: BenchChem. [Cross-validation of synthesis pathways for fluorinated hydroxyacetic acids]. BenchChem, [2026]. [Online PDF]. Available at: [<https://www.benchchem.com/product/b13606254/docs#cross-validation-of-synthesis-pathways-for-fluorinated-hydroxyacetic-acids>]

---

### Disclaimer & Data Validity:

The information provided in this document is for Research Use Only (RUO) and is strictly not intended for diagnostic or therapeutic procedures. While BenchChem strives to provide

accurate protocols, we make no warranties, express or implied, regarding the fitness of this product for every specific experimental setup.

**Technical Support:** The protocols provided are for reference purposes. Unsure if this reagent suits your experiment?

**Need Industrial/Bulk Grade?** [Request Custom Synthesis Quote](#)

## BenchChem

Our mission is to be the trusted global source of essential and advanced chemicals, empowering scientists and researchers to drive progress in science and industry.

### Contact

Address: 3281 E Guasti Rd

Ontario, CA 91761, United States

Phone: (601) 213-4426

Email: [info@benchchem.com](mailto:info@benchchem.com)

[Contact our Ph.D. Support Team for a compatibility check](#)