

Application Note: Microwave-Assisted Synthesis of Imidazole-Morpholine Scaffolds

Author: BenchChem Technical Support Team. **Date:** May 2026

Compound of Interest

Compound Name: *3-(1H-Imidazol-2-yl)morpholine*

Cat. No.: B13605032

[Get Quote](#)

Executive Summary

This application note details a robust, microwave-assisted protocol for the synthesis of 2,4,5-trisubstituted imidazole-morpholine derivatives. By fusing the pharmacologically active imidazole core with a morpholine moiety, researchers can access a privileged scaffold with broad therapeutic potential, including antifungal, antimicrobial, and anticancer properties.

This guide moves beyond conventional thermal reflux methods—which often require 4–8 hours and toxic solvents—to a Microwave-Assisted Organic Synthesis (MAOS) workflow that achieves >90% yields in under 10 minutes. The protocol utilizes a modified Debus-Radziszewski reaction, optimized for reproducibility and scalability in drug discovery campaigns.

Scientific Rationale & Mechanism

The "Pharmacophore Fusion" Strategy

The target scaffold combines two clinically validated structures:

- Imidazole: A five-membered aromatic heterocycle found in essential biomolecules (histidine) and drugs (ketoconazole, losartan). It acts as a hydrogen bond donor/acceptor and

coordinates with metal ions in enzyme active sites.

- Morpholine: A saturated O/N-heterocycle often used to modulate solubility, lipophilicity, and metabolic stability (PK properties) of drug candidates (e.g., gefitinib, linezolid).

Reaction Mechanism: Modified Debus-Radziszewski

The synthesis is a one-pot, multi-component condensation involving a 1,2-diketone (benzil), an aldehyde (4-morpholinobenzaldehyde), and an ammonia source (ammonium acetate).

Mechanistic Pathway:

- Ammonia Generation: Thermal decomposition of ammonium acetate releases ammonia ().
- Imine Formation:
condenses with the aldehyde to form an imine intermediate.
- Cyclization: The imine attacks the carbonyls of the 1,2-diketone.
- Dehydration: Loss of water molecules drives the aromatization to form the stable imidazole ring.

Why Microwave? Microwave irradiation provides dielectric heating, directly coupling with the polar reaction medium (acetic acid or polar intermediates).[1] This results in rapid, uniform internal heating, suppressing side reactions (like aldol condensations) common in slow-heating thermal mantles.

Visualization of Reaction Logic

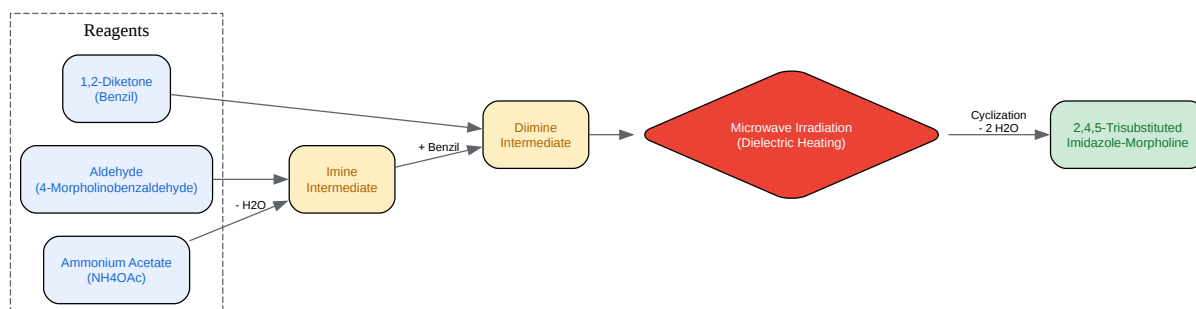

[Click to download full resolution via product page](#)

Figure 1: Mechanistic pathway for the one-pot multicomponent synthesis of imidazole-morpholine scaffolds.

Experimental Protocol

Equipment & Materials

- Microwave Reactor: Monomode reactor (e.g., Anton Paar Monowave 300 or CEM Discover) capable of pressure control.
- Vessel: 10 mL or 30 mL sealed borosilicate glass vial with Teflon/silicone septum.
- Reagents:
 - Benzil (1.0 mmol)
 - 4-Morpholinobenzaldehyde (1.0 mmol)
 - Ammonium Acetate (4.0 - 5.0 mmol, excess required)
 - Solvent: Glacial Acetic Acid (3-5 mL) or Ethanol (Green alternative, may require catalyst).

Step-by-Step Workflow

Step 1: Reaction Assembly

- Weigh 210 mg of Benzil (1.0 mmol) and 191 mg of 4-Morpholinobenzaldehyde (1.0 mmol) into a 10 mL microwave vial.
- Add 385 mg of Ammonium Acetate (5.0 mmol). Note: Excess ammonium acetate acts as both reagent and buffer.
- Add 3 mL of Glacial Acetic Acid. Add a magnetic stir bar.
- Cap the vial and vortex for 10 seconds to create a slurry.

Step 2: Microwave Irradiation Program the reactor with the following "Hold" method:

- Temperature: 180 °C (Dynamic control via IR sensor)
- Ramp Time: 2:00 minutes (Fast ramp prevents thermal lag)
- Hold Time: 5:00 minutes
- Pressure Limit: 250 psi (Safety cutoff)
- Stirring: High (600 rpm)
- Power: Max 300W (System will modulate power to maintain 180 °C).

Step 3: Workup & Isolation

- Cool the reaction mixture to 50 °C using compressed air (integrated in most reactors).
- Pour the reaction mixture slowly into 50 mL of crushed ice/water with vigorous stirring.
- Neutralize slightly with ammonium hydroxide (dropwise) if precipitation is slow (target pH ~6-7).
- A solid precipitate (yellowish to off-white) will form immediately.

- Filter the solid using a Buchner funnel and wash with cold water (3 x 10 mL) to remove excess acid and ammonium salts.

Step 4: Purification

- Recrystallization: Dissolve the crude solid in hot ethanol or an ethanol/water (9:1) mixture.
- Allow to cool slowly to room temperature, then refrigerate.
- Collect pure crystals via filtration.
- Optional: For library synthesis, automated flash chromatography (0-5% MeOH in DCM) can be used, but recrystallization is usually sufficient (>95% purity).

Workflow Diagram

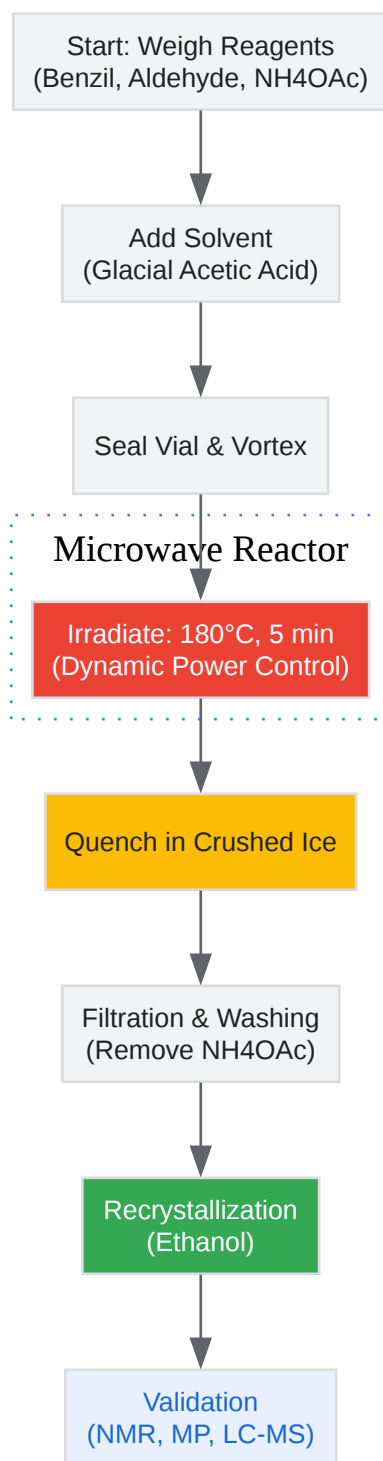

[Click to download full resolution via product page](#)

Figure 2: Operational workflow for the microwave-assisted synthesis of imidazole-morpholine derivatives.[2]

Data Analysis & Validation

Expected Results Table

Parameter	Conventional Heating (Reflux)	Microwave Protocol (This Guide)
Reaction Time	4 – 8 Hours	5 – 7 Minutes
Solvent Vol.	20 – 50 mL	3 – 5 mL
Yield	65 – 75%	92 – 96%
Energy Usage	High (Continuous heating)	Low (Targeted energy)
Purity (Crude)	Low (Requires chromatography)	High (Recrystallization only)

Characterization Checklist

To validate the synthesis of 2-(4-morpholinophenyl)-4,5-diphenyl-1H-imidazole, confirm the following signals:

- ¹H NMR (DMSO-d₆):
 - Singlet at ~12.5 ppm (of imidazole ring).
 - Multiplets at 7.2–8.0 ppm (Aromatic protons from benzil and aldehyde phenyl rings).
 - Distinct triplets at ~3.1 ppm and ~3.7 ppm (Morpholine protons).
- FT-IR:
 - Broad band at 3100–3400 cm⁻¹ (stretch).
 - Strong band at ~1600 cm⁻¹ (

stretch).

- Melting Point: Sharp range (typically >200°C, specific to derivative).

Troubleshooting & Optimization (Expertise)

- Low Yield / Sticky Product:
 - Cause: Incomplete cyclization or residual acetic acid.
 - Fix: Increase microwave hold time by 2 minutes. Ensure the quench water is ice-cold to force precipitation.
- Pressure Spikes:
 - Cause: Decomposition of ammonium acetate releases significant ammonia gas.
 - Fix: Do not exceed 50% of the vessel volume. Use a "Ramp" time of at least 2 minutes to allow controlled pressure buildup.
- Substrate Scope:
 - If using electron-withdrawing aldehydes (e.g., nitro-substituted), the reaction is faster; reduce time to 3 minutes.
 - If using sterically hindered diketones, increase temperature to 200 °C.

References

- Optimization of Microwave Assisted Synthesis of Substituted Imidazoles – A Green Approach. Oriental Journal of Chemistry. (2024). [\[Link\]](#)
- Microwave-Assisted Synthesis of Imidazole Derivatives: A Recent Update. Bentham Science. [\[Link\]](#)
- Synthesis and Biological Evaluation of Novel Imidazole Derivatives as Antimicrobial Agents. National Institutes of Health (PMC). [\[Link\]](#)

- Microwave-Assisted One Pot Three-Component Synthesis of Novel Bioactive Thiazolyl-Pyridazinediones.MDPI Molecules. [[Link](#)]

Need Custom Synthesis?

BenchChem offers custom synthesis for rare earth carbides and specific isotopic labeling.

Email: info@benchchem.com or [Request Quote Online](#).

Sources

- 1. [derpharmachemica.com](https://www.derpharmachemica.com) [[derpharmachemica.com](https://www.derpharmachemica.com)]
- 2. [researchgate.net](https://www.researchgate.net) [[researchgate.net](https://www.researchgate.net)]
- To cite this document: BenchChem. [Application Note: Microwave-Assisted Synthesis of Imidazole-Morpholine Scaffolds]. BenchChem, [2026]. [Online PDF]. Available at: [<https://www.benchchem.com/product/b13605032/docs#application-note-microwave-assisted-synthesis-of-imidazole-morpholine-scaffolds>]

Disclaimer & Data Validity:

The information provided in this document is for Research Use Only (RUO) and is strictly not intended for diagnostic or therapeutic procedures. While BenchChem strives to provide accurate protocols, we make no warranties, express or implied, regarding the fitness of this product for every specific experimental setup.

Technical Support: The protocols provided are for reference purposes. Unsure if this reagent suits your experiment?

Need Industrial/Bulk Grade? [Request Custom Synthesis Quote](#)

BenchChem

Our mission is to be the trusted global source of essential and advanced chemicals, empowering scientists and researchers to drive progress in science and industry.

Contact

Address: 3281 E Guasti Rd

Ontario, CA 91761, United States

Phone: (601) 213-4426

Email: info@benchchem.com

[Contact our Ph.D. Support Team for a compatibility check](#)