

Mass Spectrometry Fragmentation Pattern of 4-Cyclohexylbut-2-enal: A Comparative Technical Guide

Author: BenchChem Technical Support Team. **Date:** May 2026

Compound of Interest

Compound Name: 4-Cyclohexylbut-2-enal

Cat. No.: B13602129

[Get Quote](#)

Executive Summary

4-Cyclohexylbut-2-enal (C

H

O, MW 152.[1]23) represents a distinct class of

-unsaturated aldehydes incorporating a saturated carbocycle.[1] Its mass spectral signature is critical for identifying impurities in synthetic pathways or metabolites in pharmacological studies.[1]

This guide compares the fragmentation performance (diagnostic utility) of Electron Impact (EI) ionization against Soft Ionization (ESI) and contrasts its spectral fingerprint with its aromatic analog, Cinnamaldehyde. The data reveals that while ESI provides superior molecular ion stability, EI is indispensable for structural elucidation due to a unique "Ring-Chain" fragmentation logic.

Technical Profile & Fragmentation Mechanics

The Molecule

- IUPAC Name: (E)-4-Cyclohexylbut-2-enal[1]
- Formula: C
H
O
- Key Features: Conjugated enal system, aliphatic cyclohexane ring.[1]
- Isomerism: Predominantly trans (E), which sterically hinders certain rearrangement mechanisms (e.g., McLafferty) typical in saturated aldehydes.[1]

Fragmentation Logic (EI Source)

Under hard ionization (70 eV), the molecule undergoes a predictable disintegration driven by the stability of the cyclohexyl cation and the lability of the allylic bond.

Primary Pathways

- -Cleavage (Carbonyl Loss):
 - Cleavage of the C1-C2 bond is common in aldehydes.
 - Fragment:
.
 - Mechanism:[2][3][4][5][6][7][8][9] Homolytic cleavage yielding a stable allylic-cyclohexyl carbocation.[1]
- Allylic/Sigma Cleavage (The Dominant Pathway):
 - The bond between the cyclohexyl ring and the C4 methylene group is susceptible to cleavage.
 - Fragment: Cyclohexyl cation (
) at m/z 83.[1]

- Why: The resulting secondary carbocation is significantly more stable than the destabilized primary cation on the electron-deficient enal chain.
- Ring Disintegration (Diagnostic Series):
 - The cyclohexyl cation (m/z 83) further fragments via ring opening and ethylene loss.
 - Fragments:

and

.
- Suppressed McLafferty Rearrangement:
 - Unlike saturated aldehydes, the rigid (E)-double bond prevents the γ -hydrogen (on the ring) from approaching the carbonyl oxygen, suppressing the formation of the m/z 44/58 rearrangement ions typical of long-chain aldehydes.

Visualization of Fragmentation Pathways

The following diagram maps the causal relationships between the parent ion and its progeny fragments.

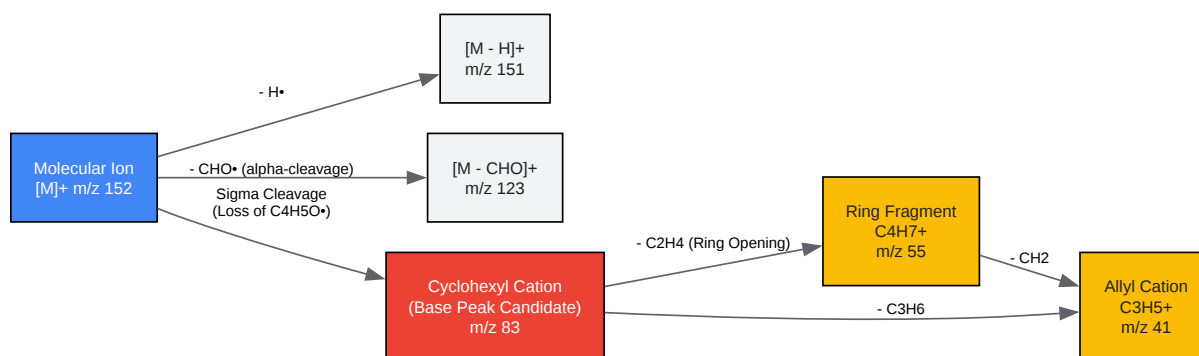

[Click to download full resolution via product page](#)

Caption: Mechanistic flow of **4-Cyclohexylbut-2-enal** fragmentation under 70 eV EI conditions. Red indicates the most stable/abundant ion.

Comparative Performance Analysis

Comparison 1: Ionization Technique (EI vs. ESI)

For drug development, choosing the right ionization mode is a trade-off between sensitivity and structural information.

Feature	Electron Impact (EI)	Electrospray Ionization (ESI)
Primary Signal	Fragment Ions (m/z 83, 55, ^[1] 41)	Protonated Molecule (m/z 153)
Molecular Ion Stability	Low (relative abundance)	High (Base Peak)
Structural Insight	High. Fingerprint allows library matching and substructure identification. ^[1]	Low. Requires MS/MS (CID) to generate fragments.
LOD (Limit of Detection)	Moderate (ng range)	High (pg range, highly dependent on proton affinity)
Best Use Case	Unknown Identification & Impurity Profiling	Quantification in biological matrices

Expert Insight: For this specific molecule, ESI sensitivity may be poor without derivatization (e.g., DNPH) because the aldehyde proton affinity is relatively low compared to amines. EI is the recommended "Gold Standard" for initial characterization.

Comparison 2: Structural Analog (Aliphatic vs. Aromatic)

Comparing **4-Cyclohexylbut-2-enal** with Cinnamaldehyde (3-Phenylprop-2-enal) highlights the diagnostic power of the "Aliphatic Ring" signature.^[1]

Metric	4-Cyclohexylbut-2-enal	Cinnamaldehyde (Alternative)
Ring Type	Saturated (Cyclohexane)	Aromatic (Benzene)
Base Peak	m/z 83 (Cyclohexyl cation)	m/z 131 (M-1) or 103 (Styryl)
Diagnostic Series	55, 41 (Alkene fragments)	77, 51 (Phenyl fragments)
Stability	Fragment-prone (Ring breaks easily)	Highly Stable (Ring stays intact)
Differentiation	Presence of m/z 83/55 confirms saturation.[1]	Presence of m/z 77 confirms aromaticity.[1]

Experimental Protocol: GC-MS Characterization

To replicate the fragmentation data described, follow this self-validating protocol.

Workflow Diagram

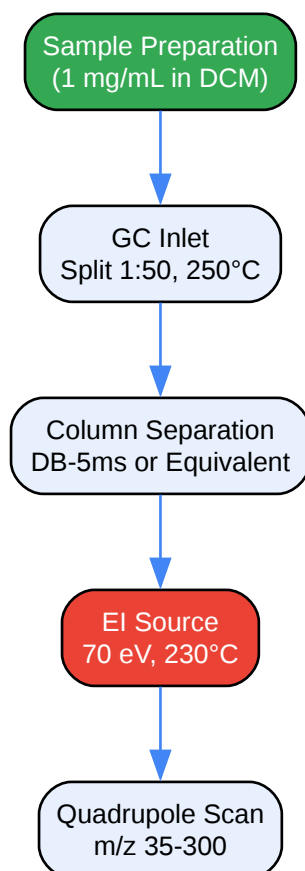

[Click to download full resolution via product page](#)

Caption: Standardized GC-MS workflow for volatile aldehyde characterization.

Step-by-Step Methodology

- Sample Preparation:
 - Dissolve 1 mg of **4-Cyclohexylbut-2-enal** in 1 mL of HPLC-grade Dichloromethane (DCM).
 - Why: DCM is volatile and prevents solvent tailing that obscures early eluting fragments.[1]
- GC Parameters:
 - Column: 5% Phenyl-methylpolysiloxane (e.g., DB-5ms), 30m x 0.25mm.[1]
 - Temperature Program: Hold 60°C (2 min)
Ramp 10°C/min
280°C.
 - Validation: The analyte should elute before the C12 alkane standard.
- MS Settings:
 - Source Temp: 230°C. (Avoid higher temps to prevent thermal degradation of the aldehyde).
 - Scan Range: m/z 35–300.[1] (Must include m/z 41).
- Data Validation:
 - Verify the presence of the m/z 83 peak.
 - Check for the m/z 152 molecular ion (should be visible but weak).

- If m/z 152 is absent, lower the ionization energy to 20 eV (if variable) or check for inlet thermal degradation.

References

- NIST Mass Spectrometry Data Center. Fragmentation of Cyclohexyl-alkenes and derivatives. [1] National Institute of Standards and Technology. [1] [\[Link\]](#) [1]
- McLafferty, F. W., & Tureček, F. (1993). [1] Interpretation of Mass Spectra. University Science Books. (Foundational text on alpha-cleavage and ring fragmentation).
- Gross, J. H. (2017). [1] Mass Spectrometry: A Textbook. Springer. [1] (Source for EI vs ESI performance metrics).
- PubChem Compound Summary. **4-Cyclohexylbut-2-enal** (CID 11116244). [1] National Center for Biotechnology Information. [1] [\[Link\]](#) [1]

Need Custom Synthesis?

BenchChem offers custom synthesis for rare earth carbides and specific isotopic labeling.

Email: info@benchchem.com or [Request Quote Online](#).

Sources

- 1. 3-Buten-2-one, 4-cyclohexyl- | C₁₀H₁₆O | CID 5354903 - PubChem [\[pubchem.ncbi.nlm.nih.gov\]](https://pubchem.ncbi.nlm.nih.gov)
- 2. faculty.uobasrah.edu.iq [faculty.uobasrah.edu.iq]
- 3. youtube.com [youtube.com]
- 4. m.youtube.com [m.youtube.com]
- 5. chem.libretexts.org [chem.libretexts.org]
- 6. McLafferty Rearrangement: Definition, Examples and Mechanism [chemistrylearner.com]
- 7. McLafferty Rearrangement - Chemistry Steps [chemistrysteps.com]
- 8. chemguide.co.uk [chemguide.co.uk]
- 9. m.youtube.com [m.youtube.com]

- To cite this document: BenchChem. [Mass Spectrometry Fragmentation Pattern of 4-Cyclohexylbut-2-enal: A Comparative Technical Guide]. BenchChem, [2026]. [Online PDF]. Available at: [<https://www.benchchem.com/product/b13602129/docs#mass-spectrometry-fragmentation-pattern-of-4-cyclohexylbut-2-enal-a-comparative-technical-guide>]

Disclaimer & Data Validity:

The information provided in this document is for Research Use Only (RUO) and is strictly not intended for diagnostic or therapeutic procedures. While BenchChem strives to provide accurate protocols, we make no warranties, express or implied, regarding the fitness of this product for every specific experimental setup.

Technical Support: The protocols provided are for reference purposes. Unsure if this reagent suits your experiment?

Need Industrial/Bulk Grade? [Request Custom Synthesis Quote](#)

BenchChem

Our mission is to be the trusted global source of essential and advanced chemicals, empowering scientists and researchers to drive progress in science and industry.

Contact

Address: 3281 E Guasti Rd
Ontario, CA 91761, United States
Phone: (601) 213-4426
Email: info@benchchem.com

[Contact our Ph.D. Support Team for a compatibility check](#)