

Technical Guide: Novel O-Substituted Hydroxylamine Building Blocks in Drug Discovery

Author: BenchChem Technical Support Team. **Date:** April 2026

Compound of Interest

Compound Name:	3-(Aminoxy)-2,2-dimethyl-1-propanol
CAS No.:	391212-31-0
Cat. No.:	B13600340

[Get Quote](#)

Executive Summary

The Renaissance of the N–O Bond Historically viewed merely as precursors to oximes or as potentially mutagenic liabilities, O-substituted hydroxylamines (

) have undergone a radical transformation in modern medicinal chemistry. They have evolved from simple nucleophiles into versatile electrophilic amination reagents and bioisosteres (hydroxalogs) that defy traditional metabolic instability paradigms.

This guide analyzes the dual utility of these building blocks:

- As Electrophiles: Reagents like O-benzoyl and O-pivaloyl hydroxylamines enable transition-metal-free C–H amination and alkene difunctionalization.
- As Pharmacophores: The N,N,O-trisubstituted hydroxylamine moiety is emerging as a stable, non-basic bioisostere for tertiary amines, offering novel IP space and altered physicochemical profiles (logD, pKa).

Part 1: Structural Classes & Pharmacological Relevance

The "Hydroxalog" Concept (Bioisosteres)

Recent work, notably by the Crich and Buchwald groups, has validated N,N,O-trisubstituted hydroxylamines as "hydroxalogs"—bioisosteres of tertiary amines.

- **Mechanism of Utility:** Unlike tertiary amines, hydroxalogs are often non-basic ($pK_a < 6$), reducing lysosomal trapping and hERG channel inhibition while maintaining H-bond accepting capability.
- **Stability:** Contrary to the "mutagenicity" dogma associated with unsubstituted hydroxylamines, sterically hindered trisubstituted variants exhibit remarkable metabolic stability against oxidative N-dealkylation.

Electrophilic Amination Reagents

These are "transfer" building blocks used to install amino groups onto arenes, heterocycles, and olefins.^[1]

- **Class I: Acyloxy Amines:**

(e.g., O-benzoyl hydroxylamines). Stable solids used in Cu/Pd-catalyzed aminations.

- **Class II: Sulfonyloxy Amines:**

(e.g., MSH, hydroxylamine-O-sulfonic acid). Highly reactive, often generated in situ for metal-free aminations.

Part 2: Strategic Synthesis of the Building Blocks

The synthesis of these blocks requires navigating the "ambident" nucleophilicity of the nitrogen and oxygen atoms.

Method A: The Modern Mitsunobu Route (Nucleophilic Oxygen)

For creating O-alkyl hydroxylamines (e.g., PROTAC linkers, ADC handles), the Mitsunobu reaction remains the gold standard for installing the

bond with inversion of configuration at the alcohol center.

- The Trap: Direct reaction with

 fails due to N-alkylation and over-alkylation.
- The Solution: Use of N-hydroxyphthalimide (NHPI) or N-hydroxycarbamates (e.g., N-Boc-OH) as masked nucleophiles.

Critical Insight: The choice of phosphine/azodicarboxylate is non-trivial for hindered alcohols.

- Standard:

 / DEAD (often fails for secondary alcohols).
- Optimized:

 / ADDP (1,1'-(azodicarbonyl)dipiperidine) provides higher driving force for sterically demanding substrates.

Method B: Electrophilic N–O Bond Formation (The "Crich" Approach)

Synthesizing N,N,O-trisubstituted blocks is difficult via alkylation due to steric crowding. A novel approach involves the direct formation of the N–O bond.^{[2][3][4]}

- Protocol: Reaction of a secondary amine with a peroxide (e.g., benzoyl peroxide) followed by hydrolysis/reduction.
- Advantage: This "umpolung" strategy avoids

 limitations and allows access to sterically congested "hydroxalogs" (e.g., piperidine derivatives).

Part 3: Visualization of Reaction Pathways

Diagram 1: The Dual Nature of Hydroxylamine Reactivity

This diagram illustrates the divergent workflows: using the building block as a Nucleophile (Oxime Ligation) vs. an Electrophile (C-H Amination).

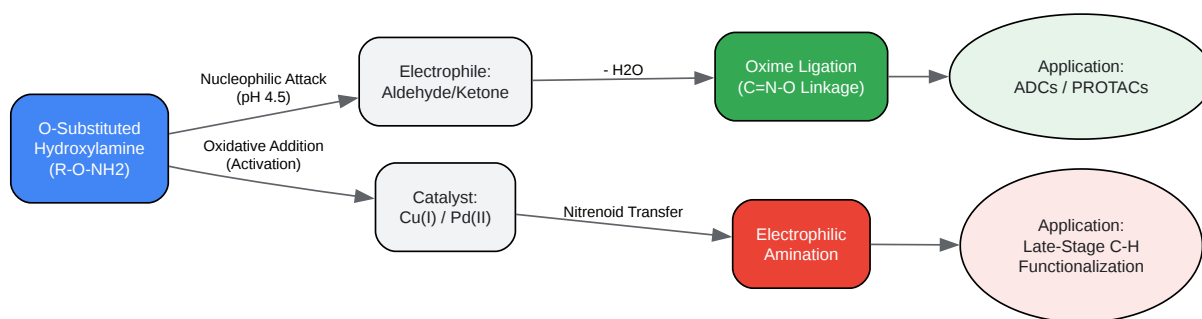

[Click to download full resolution via product page](#)

Caption: Divergent reaction pathways for O-substituted hydroxylamines: Nucleophilic condensation vs. Electrophilic nitrene transfer.

Part 4: Experimental Protocols

Protocol 1: Synthesis of a Novel O-Alkynyl Hydroxylamine Linker

Objective: Create a "Click-ready" hydroxylamine building block for bioconjugation using a modified Mitsunobu-Hydrazinolysis sequence.

Reagents:

- Substrate: 3-butyn-1-ol (1.0 equiv)
- Nucleophile: N-Hydroxyphthalimide (NHPI) (1.1 equiv)
- Reagents: (1.2 equiv), DIAD (1.2 equiv)

- Solvent: Anhydrous THF
- Deprotection: Hydrazine monohydrate ()

Step-by-Step Methodology:

- Mitsunobu Coupling:
 - Charge a flame-dried flask with NHPI (1.1 equiv), (1.2 equiv), and 3-butyn-1-ol (1.0 equiv) in anhydrous THF (0.2 M).
 - Cool to 0°C under .
 - Add DIAD (1.2 equiv) dropwise over 30 mins. Note: Exothermic. Maintain T < 5°C to prevent hydrazine dicarboxylate byproduct precipitation.
 - Warm to RT and stir for 12h. Monitor by TLC (disappearance of alcohol).
 - Workup: Concentrate and triturate with cold MeOH. Filter off the solid triphenylphosphine oxide (TPPO).[5] The filtrate contains the phthalimide intermediate. Purify via silica flash chromatography (Hex/EtOAc).
- Hydrazinolysis (The Critical Step):
 - Dissolve the purified phthalimide intermediate in DCM/MeOH (1:1).
 - Add Hydrazine monohydrate (2.0 equiv) at 0°C.
 - Observation: A white precipitate (phthalhydrazide) will form within 15 mins.
 - Stir at RT for 2h.
 - Filtration: Filter the slurry through a Celite pad to remove phthalhydrazide.

- Acid Extraction (Self-Validating Step): The filtrate contains the amine. Extract with 1N HCl. The product moves to the aqueous phase (protonated), leaving non-basic impurities in the organic phase. Wash aqueous layer with .
- Basify aqueous layer (pH > 10) with 2N NaOH and extract into DCM. Dry () and concentrate.

Yield Expectation: 75-85% (2 steps). Storage: Store as the HCl salt at -20°C. Free bases of small O-alkyl hydroxylamines are volatile and prone to oxidation.

Protocol 2: Electrophilic Amination using O-Benzoyl Hydroxylamines

Objective: Direct C-H amination of an indole derivative.

- Reagent Prep: React N-Boc-hydroxylamine with Benzoyl chloride (, DCM), then deprotect (TFA/DCM) to yield (TFA salt).
- Amination:
 - Mix Indole substrate (1.0 equiv) and (1.2 equiv) in DCE.
 - Add Catalyst: (2 mol%).
 - Heat to 60°C.
 - Mechanism: The Rh-catalyst generates a metal-nitrene species from the hydroxylamine, which inserts into the C3-H bond of the indole.

Part 5: Data Summary & Stability

Table 1: Comparison of Electrophilic Aminating Reagents

Reagent	Structure	Reactivity	Stability	Primary Application
MSH		High	Low (Explosive if dry)	Metal-free amination of pyridines
DPH		High	Moderate	Amination of Grignard reagents
O-Bz-NH ₂		Moderate	High (Bench stable)	Cu/Rh-catalyzed C-H amination
PivONH ₃ OTf		High	High	Transfer to alkenes/arenes

Safety & Handling (The "Trustworthiness" Pillar)

- **Explosion Hazard:** Low molecular weight O-sulfonyl hydroxylamines (like MSH) are shock-sensitive. Never store them dry. Always generate in situ or store as wet cakes/solutions.
- **Toxicity:** Hydroxylamines are potent mutagens (Ames positive). All handling must occur in a fume hood with double-gloving.
- **Validation:** Verify the integrity of O-substituted hydroxylamines via ¹H NMR. The protons typically shift downfield (3.5 - 4.2 ppm) compared to the parent alcohol.

References

- Recent Advances in the Synthesis of Di- and Trisubstituted Hydroxylamines. Source: National Institutes of Health (NIH) / PMC. URL:[[Link](#)]

- Electrophilic Amination: A Renaissance of the N-O Bond. Source: Royal Society of Chemistry (Organic & Biomolecular Chemistry).^[6] URL:[[Link](#)]
- A New Supported Reagent for the Parallel Synthesis of O-Alkyl Hydroxylamines. Source: ACS Publications (Journal of Organic Chemistry). URL:[[Link](#)]
- Expanding the Versatility of Oxime Ligation: Rapid Bioconjugation. Source: Chemical Science (via NIH). URL:[[Link](#)]
- Mitsunobu Reaction: Mechanism and Modifications. Source: Organic Chemistry Portal. URL:[[Link](#)]

Need Custom Synthesis?

BenchChem offers custom synthesis for rare earth carbides and specific isotopic labeling.

Email: info@benchchem.com or [Request Quote Online](#).

Sources

- [1. researchgate.net \[researchgate.net\]](https://www.researchgate.net)
- [2. Trisubstituted hydroxylamines: From reaction discovery to drug design - American Chemical Society \[acs.digitellinc.com\]](https://pubs.acs.org)
- [3. Recent Advances in the Synthesis of Di- and Trisubstituted Hydroxylamines - PMC \[pmc.ncbi.nlm.nih.gov\]](https://pubmed.ncbi.nlm.nih.gov)
- [4. Synthesis of N,N,O-Trisubstituted Hydroxylamines \(Hydroxalogs\) and Other Projects | Department of Chemistry \[chem.uga.edu\]](https://chem.uga.edu)
- [5. organic-synthesis.com \[organic-synthesis.com\]](https://www.organic-synthesis.com)
- [6. O-Substituted hydroxyl amine reagents: an overview of recent synthetic advances - Organic & Biomolecular Chemistry \(RSC Publishing\) \[pubs.rsc.org\]](https://pubs.rsc.org)
- To cite this document: BenchChem. [Technical Guide: Novel O-Substituted Hydroxylamine Building Blocks in Drug Discovery]. BenchChem, [2026]. [Online PDF]. Available at: [<https://www.benchchem.com/product/b13600340/docs#technical-guide-novel-o-substituted-hydroxylamine-building-blocks-in-drug-discovery>]

Disclaimer & Data Validity:

The information provided in this document is for Research Use Only (RUO) and is strictly not intended for diagnostic or therapeutic procedures. While BenchChem strives to provide accurate protocols, we make no warranties, express or implied, regarding the fitness of this product for every specific experimental setup.

Technical Support: The protocols provided are for reference purposes. Unsure if this reagent suits your experiment?

Need Industrial/Bulk Grade? [Request Custom Synthesis Quote](#)

BenchChem

Our mission is to be the trusted global source of essential and advanced chemicals, empowering scientists and researchers to drive progress in science and industry.

Contact

Address: 3281 E Guasti Rd
Ontario, CA 91761, United States
Phone: (601) 213-4426
Email: info@benchchem.com

[Contact our Ph.D. Support Team for a compatibility check](#)