

# Precision Mapping of the Sulfonyl Fluoride Reactome: A Comparative MS Guide

**Author:** BenchChem Technical Support Team. **Date:** April 2026

## Compound of Interest

Compound Name: 6-Aminopyridine-3-sulfonylfluoridehydrochloride  
Cat. No.: B13600269

[Get Quote](#)

## Executive Summary

The resurgence of Sulfur-Fluoride Exchange (SuFEx) chemistry has revolutionized chemical proteomics, moving covalent targeting "beyond cysteine" to residues previously considered difficult to drug: Tyrosine (Tyr), Lysine (Lys), Histidine (His), and Serine (Ser).[1] Unlike traditional Fluorophosphonate (FP) probes that strictly target active-site serines in hydrolases, Sulfonyl Fluoride (SF) probes exhibit context-dependent reactivity, driven by the local protein microenvironment rather than a specific catalytic mechanism.

This guide provides a technical comparison of mass spectrometry (MS) workflows for mapping SF modification sites. It synthesizes experimental protocols with data interpretation strategies, offering researchers a blueprint for identifying "ligandable" hotspots in the proteome.[2]

## Mechanism & Reactivity: The SuFEx Advantage

To accurately interpret MS data, one must understand the underlying chemistry. SF probes function via nucleophilic substitution at the sulfur center.

- Reaction Logic: The fluoride ion is a good leaving group only when the sulfur center is activated by the local protein environment (e.g., hydrogen bonding or proximity to basic residues like Arg/His).
- Residue Specificity:
  - Tyrosine (Tyr): The phenol group attacks the sulfur, forming a stable sulfonate ester.
  - Lysine (Lys): The -amino group forms a sulfonamide. Note: This blocks Trypsin cleavage at the modified Lys site.
  - Serine (Ser) / Histidine (His): Less common but observed in specific catalytic triads or zinc-binding sites.

### Diagram 1: SuFEx Reaction Mechanism & Residue Scope[3]

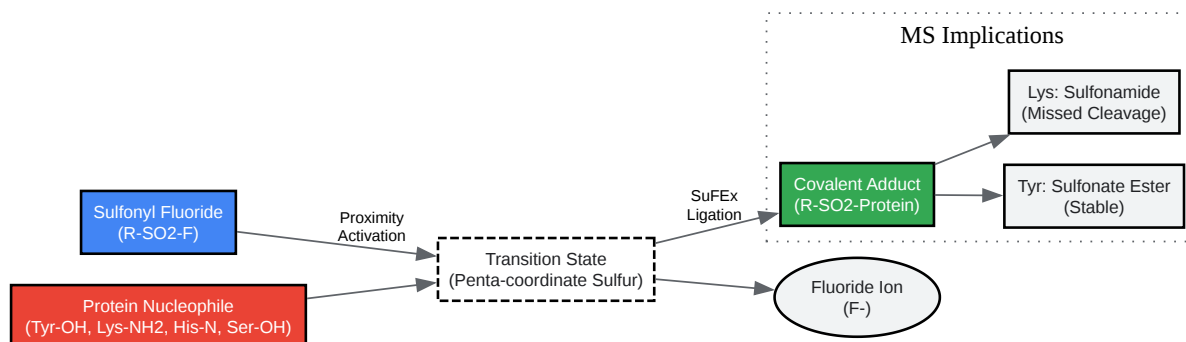

[Click to download full resolution via product page](#)

Caption: The SuFEx reaction replaces the fluoride leaving group with a protein nucleophile. Note that Lysine modification neutralizes the positive charge, preventing Trypsin cleavage at that site.

## Comparative Analysis: SF Probes vs. Alternatives

Selecting the right probe determines the depth of proteome coverage. The table below contrasts SF probes with Fluorophosphonates (FP) and Acrylamides.

Feature	Sulfonyl Fluoride (SF)	Fluorophosphonate (FP)	Acrylamide / Vinyl Sulfone
Primary Target	Tyr, Lys (Context-driven)	Ser (Active site only)	Cys (Nucleophilic)
Enzyme Class	Kinases, GSTs, Non-enzymes	Serine Hydrolases	Kinases (Cys-rich), E3 Ligases
Reactivity	Tunable (depends on R-group)	High (Active site directed)	Moderate to High
MS Challenge	Variable sites (requires open search or multiple variable mods)	Predictable (Active site Ser)	Predictable (Cys alkylation)
Stability	High (Hydrolysis resistant)	High	High
Key Advantage	Targets "undruggable" sites lacking Cys	Gold standard for hydrolase profiling	Standard for TCI drug discovery

## Experimental Protocol: The "Click-Map-Digest"

### Workflow

This protocol outlines the Activity-Based Protein Profiling (ABPP) strategy for SF probes, optimized for high-confidence site identification.

#### Phase A: Labeling & Enrichment<sup>[4]</sup>

- Lysate Prep: Prepare fresh cell lysate in PBS (pH 7.4). Avoid Tris buffers if using high concentrations of highly reactive probes, though SF is generally compatible.
- Probe Incubation: Add Alkyne-SF probe (1-50  $\mu$ M). Incubate 1 hr at 37°C.
  - Control: Pre-incubate with excess competitor or use DMSO vehicle.

- Click Chemistry (CuAAC):
  - Add reagents: Azide-Biotin (100  $\mu$ M), TCEP (1 mM), TBTA (100  $\mu$ M), CuSO<sub>4</sub> (1 mM).
  - Incubate 1 hr at RT.
- Precipitation: MeOH/CHCl<sub>3</sub> precipitate to remove excess probe.
- Enrichment: Redissolve in 1% SDS, dilute to 0.2% SDS, and incubate with Streptavidin-Agarose beads.

## Phase B: On-Bead Digestion (Critical Step)

- Reduction/Alkylation: DTT (10 mM) followed by Iodoacetamide (50 mM) on beads.
- Enzyme Selection:
  - Trypsin: Standard, but remember Lys-modification blocks cleavage. This results in longer peptides carrying the modification.
  - Chymotrypsin/GluC: Use as a complementary digest if Tyr-modification sites are in Lys/Arg-poor regions.
- Digestion: Overnight at 37°C. Collect supernatant.

## Diagram 2: ABPP MS Workflow

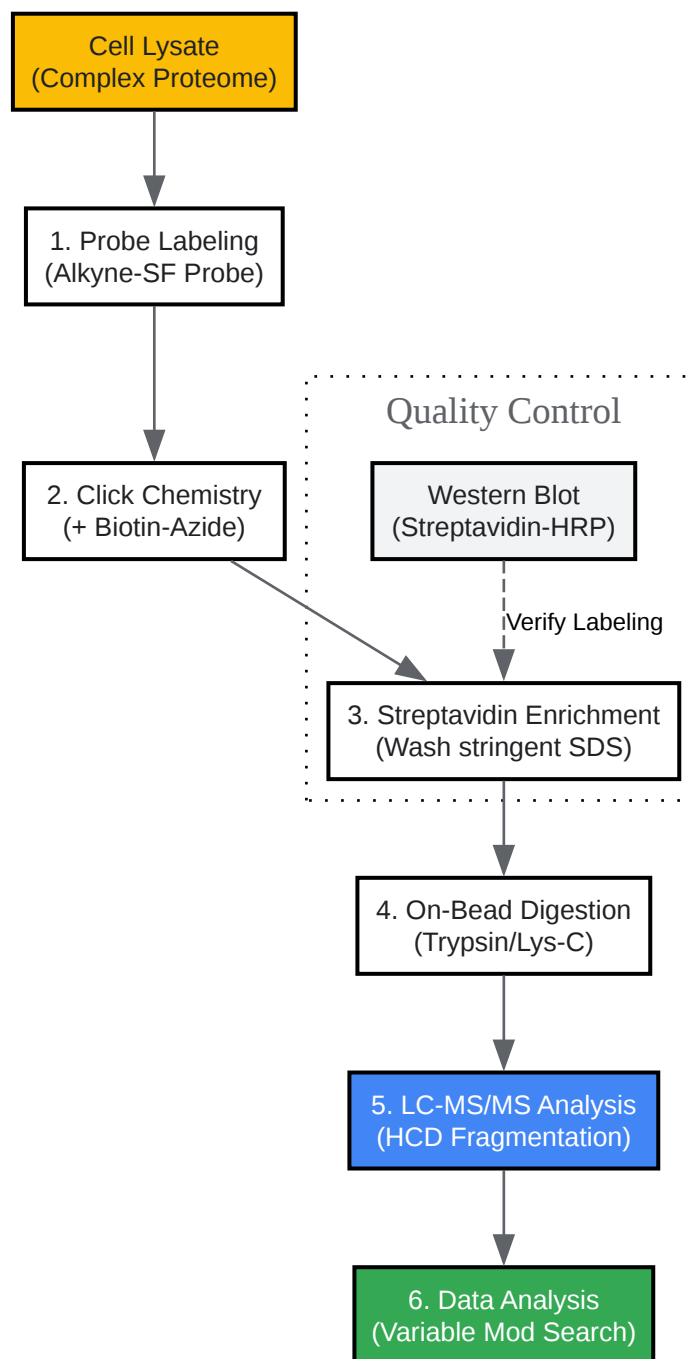

[Click to download full resolution via product page](#)

Caption: Step-by-step ABPP workflow for SF probes. Stringent washing (Step 3) is crucial to remove non-covalent binders.

## Mass Spectrometry & Data Analysis

### Instrument Parameters

- Ionization: ESI (Electrospray Ionization).[\[1\]](#)[\[3\]](#)
- Fragmentation: HCD (Higher-energy Collisional Dissociation) is preferred. SF adducts are stable and do not typically require ETD.
- Collision Energy: NCE 28-32%.

## Search Engine Configuration (MaxQuant / Proteome Discoverer)

To identify the site, you must define the specific mass shift.

- Calculate Mass Shift:
  - Example: If Probe MW = 300.0 Da,  
.
- Variable Modifications:
  - Allow modification on: Y, K, H, S, T.
  - Expert Tip: Do NOT set it as a fixed modification. The labeling is rarely 100%.
- Enzyme Specificity:
  - Select Trypsin/P.[\[5\]](#)
  - Max. Missed Cleavages: Increase to 3 or 4.
  - Reasoning: If a Lysine is modified by the SF probe, Trypsin cannot cut there. The peptide will be longer, containing an internal modified Lysine.

## Diagnostic Validation

- Site Localization Probability: Filter for Class I sites (localization probability > 0.75 or > 0.9 depending on software).
- Manual Inspection: Check MS/MS spectra for b- and y-ion series continuity around the modified residue.

- Neutral Loss: Unlike phosphopeptides, SF adducts rarely show dominant neutral losses, making site localization more straightforward.

## Case Study Data: Tyrosine vs. Lysine Selectivity

Comparing a standard aryl-SF probe against a fluorosulfate (OSF) probe highlights the "tunability" of SuFEx chemistry.

Metric	Aryl-SF Probe (High Reactivity)	Fluorosulfate (OSF) Probe (Latent)
Total Sites ID'd	> 1,500	~ 200
Residue Bias	~60% Tyr, ~30% Lys, ~10% His/Ser	~50% Tyr, ~40% His, <5% Lys
Kinase Coverage	Broad (targets conserved Lys)	Restricted (requires specific geometry)
Off-Target Rate	Moderate	Low

Data synthesized from comparative chemoproteomic studies (see References).

## References

- Jones, L. H. (2020). Structure-based design and analysis of SuFEx chemical probes. NIH National Library of Medicine. [\[Link\]](#)
- Hymel, D., et al. (2023). Direct mapping of ligandable tyrosines and lysines in cells with chiral sulfonyl fluoride probes. [\[6\]](#) eScholarship. [\[Link\]](#)
- Narayanan, A., & Jones, L. H. (2015). Sulfonyl fluorides as privileged warheads in chemical biology. Chemical Science. [\[7\]](#) [\[Link\]](#)
- Cravatt, B. F., et al. (2008). Activity-based protein profiling: from enzyme chemistry to proteomic chemistry. Annual Review of Biochemistry. [\[Link\]](#)
- Mortenson, D. E., et al. (2018). Sulfonyl Fluorides as Probes for Chemical Proteomics. [\[8\]](#) Journal of the American Chemical Society. [\[Link\]](#)

### Need Custom Synthesis?

BenchChem offers custom synthesis for rare earth carbides and specific isotopic labeling.

Email: [info@benchchem.com](mailto:info@benchchem.com) or [Request Quote Online](#).

## Sources

- [1. pdf.benchchem.com \[pdf.benchchem.com\]](https://pdf.benchchem.com)
- [2. Efficient Ligand Discovery Using Sulfur\(VI\) Fluoride Reactive Fragments - PMC \[pmc.ncbi.nlm.nih.gov\]](#)
- [3. The proximity-enabled sulfur fluoride exchange reaction in the protein context - PMC \[pmc.ncbi.nlm.nih.gov\]](#)
- [4. pdf.benchchem.com \[pdf.benchchem.com\]](https://pdf.benchchem.com)
- [5. Unbiased Mass Spectrometry Elucidation of the Targets and Mechanisms of Activity-Based Probes: A Case Study Involving Sulfonyl Fluorides - PubMed \[pubmed.ncbi.nlm.nih.gov\]](#)
- [6. escholarship.org \[escholarship.org\]](https://escholarship.org)
- [7. pubs.acs.org \[pubs.acs.org\]](https://pubs.acs.org)
- [8. pnas.org \[pnas.org\]](https://pnas.org)
- To cite this document: BenchChem. [Precision Mapping of the Sulfonyl Fluoride Reactome: A Comparative MS Guide]. BenchChem, [2026]. [Online PDF]. Available at: [\[https://www.benchchem.com/product/b13600269/docs#precision-mapping-of-the-sulfonyl-fluoride-reactome-a-comparative-ms-guide\]](https://www.benchchem.com/product/b13600269/docs#precision-mapping-of-the-sulfonyl-fluoride-reactome-a-comparative-ms-guide)

---

### Disclaimer & Data Validity:

The information provided in this document is for Research Use Only (RUO) and is strictly not intended for diagnostic or therapeutic procedures. While BenchChem strives to provide accurate protocols, we make no warranties, express or implied, regarding the fitness of this product for every specific experimental setup.

**Technical Support:** The protocols provided are for reference purposes. Unsure if this reagent suits your experiment?

**Need Industrial/Bulk Grade?** [Request Custom Synthesis Quote](#)

## BenchChem

Our mission is to be the trusted global source of essential and advanced chemicals, empowering scientists and researchers to drive progress in science and industry.

### Contact

Address: 3281 E Guasti Rd  
Ontario, CA 91761, United States  
Phone: (601) 213-4426  
Email: [info@benchchem.com](mailto:info@benchchem.com)

[Contact our Ph.D. Support Team for a compatibility check](#)