

Spectroscopic Profiling of Phenoxy-Substituted Acetophenones: A Comparative Technical Guide

Author: BenchChem Technical Support Team. **Date:** April 2026

Compound of Interest

Compound Name:	1-(4-(3,5-Dimethylphenoxy)phenyl)ethanone
CAS No.:	834885-04-0
Cat. No.:	B1360940

[Get Quote](#)

Executive Summary & Application Context

Phenoxy-substituted acetophenones represent a critical scaffold in medicinal chemistry, serving as precursors for heterocycles (indoles, benzofurans) and as core pharmacophores in non-steroidal anti-inflammatory drugs (NSAIDs) and analgesic agents.

For the structural chemist, distinguishing between

-phenoxyacetophenone (phenacyl phenyl ether) and ring-substituted phenoxyacetophenones (e.g., 4-phenoxyacetophenone) is a frequent analytical challenge. While they share the same molecular formula (

) and functional groups, their electronic environments differ radically, leading to distinct spectroscopic signatures.

This guide provides a definitive comparison of these isomers against the acetophenone baseline, synthesizing IR, NMR, and UV-Vis data to establish a self-validating identification

protocol.

Structural Classes & Electronic Theory

To interpret the spectra accurately, one must understand the electronic influence of the phenoxy group (

) depending on its position relative to the carbonyl.

Class A: -Phenoxyacetophenone (2-Phenoxy-1-phenylethanone)

- Structure: The phenoxy group is attached to the -carbon ().
- Electronic Effect: The oxygen atom exerts a strong Inductive Withdrawal () effect on the carbonyl group through the -bond framework. There is no direct resonance conjugation between the phenoxy lone pairs and the carbonyl -system.
- Predicted Outcome: Increased carbonyl bond order (higher IR frequency) and significant deshielding of methylene protons.

Class B: 4-Phenoxyacetophenone (p-Phenoxyacetophenone)

- Structure: The phenoxy group is attached to the para-position of the benzene ring.
- Electronic Effect: The oxygen atom acts primarily as a Resonance Donor (). The lone pair delocalizes into the benzene ring and the carbonyl group.

- Predicted Outcome: Decreased carbonyl bond order (lower IR frequency) and shielding of aromatic protons ortho to the ether linkage.

Synthesis & Workflow Visualization

The synthetic origin of the sample often dictates the impurity profile and spectral expectations.

Diagram 1: Comparative Synthetic Pathways

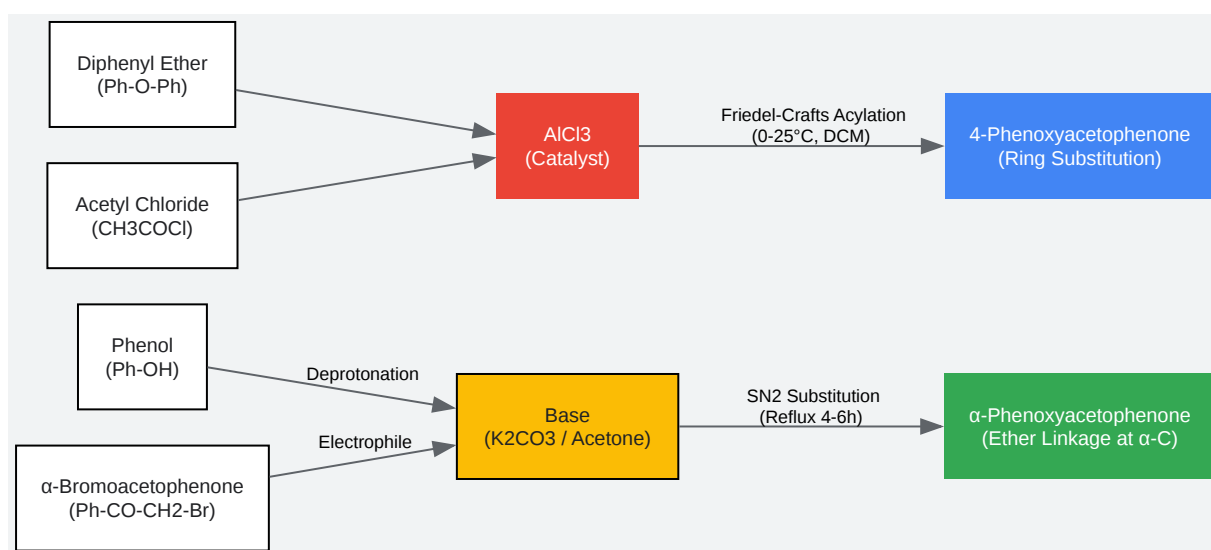

[Click to download full resolution via product page](#)

Caption: Divergent synthetic pathways for isomeric phenoxy-acetophenones. Path A (Williamson) yields the

-isomer; Path B (Friedel-Crafts) yields the ring-substituted isomer.

Spectroscopic Comparison Data

Infrared Spectroscopy (FT-IR)

The carbonyl stretching frequency (

) is the most reliable diagnostic marker for distinguishing electronic effects.

Compound	()	Electronic Rationale
Acetophenone (Baseline)	1686	Conjugation with phenyl ring lowers from aliphatic ketone (~1715).
-Phenoxyacetophenone	1695 - 1705	Inductive Effect (): The electronegative -oxygen withdraws electron density, shortening the bond and raising the frequency.
4-Phenoxyacetophenone	1675 - 1680	Resonance Effect (): Phenoxy lone pair donation increases single-bond character of the carbonyl, lowering the frequency.

Proton NMR (-NMR)

NMR provides the definitive structural proof. The presence of a

singlet vs. a

singlet is the primary differentiator.

Feature	Acetophenone	- Phenoxyacetophen one	4- Phenoxyacetophen one
Aliphatic Protons	2.60 (s, 3H) ()	5.30 (s, 2H) ()	2.55 (s, 3H) ()
Ortho Protons (to C=O)	7.96 (d)	8.00 (d)	7.93 (d)
Ortho Protons (to O-Ph)	N/A	6.9 - 7.0 (m) (on phenoxy ring)	6.98 (d) (on central ring)
Multiplicity Pattern	Multiplet	Complex Multiplet (2 rings)	AA'BB' System (Central Ring)

Key Diagnostic:

- Look for the downfield singlet at ~5.3 ppm. If present, it is the -isomer.
- Look for the AA'BB' pattern (two doublets with "roofing" effect) in the aromatic region. This strongly suggests para-substitution.

UV-Vis Spectroscopy

Solvent: Methanol (MeOH)

Compound	(nm)	Transition Type	Interpretation
Acetophenone	244, 280 (weak)	,	Baseline benzene conjugation.
- Phenoxyacetophenone	~245, 275		Minimal extension of conjugation. Spectrum appears as a summation of acetophenone + phenol.
4- Phenoxyacetophenone	265 - 285		Bathochromic Shift: Extended conjugation through the ether linkage allows delocalization across the entire biphenyl-like system.

Detailed Experimental Protocols

Protocol A: Synthesis of -Phenoxyacetophenone (Williamson Ether)

This protocol is optimized for high yield and minimal side products.

- Reagent Prep: Dissolve Phenol (10 mmol, 0.94 g) and Potassium Carbonate (, 15 mmol, 2.07 g) in anhydrous Acetone (30 mL).
- Activation: Stir at room temperature for 15 minutes to generate the phenoxide anion in situ.
- Addition: Add -Bromoacetophenone (Phenacyl bromide, 10 mmol, 1.99 g) dropwise over 10 minutes. Note: Phenacyl bromide is a lachrymator; work in a fume hood.

- Reflux: Heat the mixture to reflux () for 4 hours. Monitor by TLC (Eluent: 8:2 Hexane/Ethyl Acetate).
- Workup:
 - Filter off the inorganic salts (, excess).
 - Evaporate the acetone solvent under reduced pressure.[2]
 - Dissolve residue in Ethyl Acetate (20 mL) and wash with 10% NaOH (to remove unreacted phenol) followed by Brine.
- Purification: Recrystallize from Ethanol/Water (1:1).
 - Target Yield: 85-90%
 - Appearance: White crystalline solid (MP: 70-72°C).

Protocol B: Spectroscopic Acquisition Parameters

To ensure data comparable to the tables above, use these standard settings:

- NMR ():
 - Solvent: (Deuterated Chloroform) with 0.03% TMS.
 - Frequency: 400 MHz or higher recommended for resolving aromatic multiplets.
 - Relaxation Delay (): 1.0 s (Standard) or 5.0 s (Quantitative).

- FT-IR:
 - Method: KBr Pellet (1-2 mg sample in 100 mg KBr) or ATR (Attenuated Total Reflectance).
 - Resolution: 4
 - [. \[3\]](#)
 - Scans: 16 minimum.

Logic Diagram: Identification Workflow

Use this decision tree to identify an unknown phenoxy-acetophenone derivative.

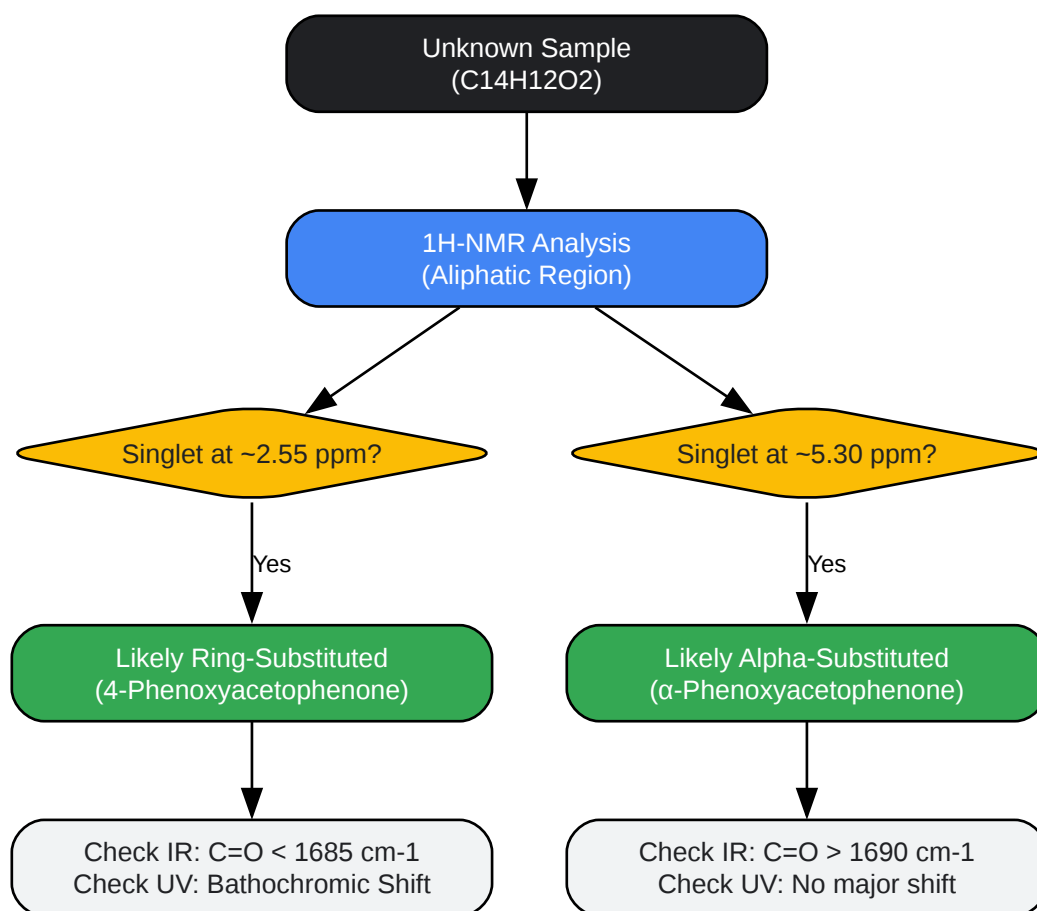

[Click to download full resolution via product page](#)

Caption: Step-by-step logic for distinguishing isomers using primary NMR signals and secondary IR/UV confirmation.

References

- BenchChem.Spectroscopic Profile of 2'-Hydroxyacetophenone: A Technical Guide. Retrieved from
- National Institute of Standards and Technology (NIST).Acetophenone - Gas Phase IR and Mass Spectra. NIST Chemistry WebBook, SRD 69.[4] Retrieved from
- PubChem.2-Phenoxy-1-phenylethanone (Compound CID 222171). National Center for Biotechnology Information. Retrieved from
- SpectraBase.Acetophenone, 4'-phenoxy- IR and NMR Data.[5] John Wiley & Sons.[6][5][7] Retrieved from
- Gordon College.The Williamson Ether Synthesis: Synthesis of Phenoxyacetic Acid Derivatives. Organic Chemistry Laboratory Manual. Retrieved from
- Royal Society of Chemistry (RSC).Proton chemical shifts in acetylenes and aromatic derivatives. Retrieved from

Need Custom Synthesis?

BenchChem offers custom synthesis for rare earth carbides and specific isotopic labeling.

Email: info@benchchem.com or [Request Quote Online](#).

Sources

- [1. pdf.benchchem.com](https://pdf.benchchem.com) [pdf.benchchem.com]
- [2. organic-synthesis.com](https://organic-synthesis.com) [organic-synthesis.com]
- [3. scholarship.richmond.edu](https://scholarship.richmond.edu) [scholarship.richmond.edu]
- [4. Acetophenone](https://webbook.nist.gov) [webbook.nist.gov]
- [5. spectrabase.com](https://spectrabase.com) [spectrabase.com]
- [6. p-Ethoxyacetophenone | C₁₀H₁₂O₂ | CID 72872 - PubChem](https://pubchem.ncbi.nlm.nih.gov) [pubchem.ncbi.nlm.nih.gov]
- [7. 2-Phenoxy-1-phenylethanone | C₁₄H₁₂O₂ | CID 222171 - PubChem](https://pubchem.ncbi.nlm.nih.gov) [pubchem.ncbi.nlm.nih.gov]

- To cite this document: BenchChem. [Spectroscopic Profiling of Phenoxy-Substituted Acetophenones: A Comparative Technical Guide]. BenchChem, [2026]. [Online PDF]. Available at: [<https://www.benchchem.com/product/b1360940/docs#spectroscopic-profiling-of-phenoxy-substituted-acetophenones-a-comparative-technical-guide>]

Disclaimer & Data Validity:

The information provided in this document is for Research Use Only (RUO) and is strictly not intended for diagnostic or therapeutic procedures. While BenchChem strives to provide accurate protocols, we make no warranties, express or implied, regarding the fitness of this product for every specific experimental setup.

Technical Support: The protocols provided are for reference purposes. Unsure if this reagent suits your experiment?

Need Industrial/Bulk Grade? [Request Custom Synthesis Quote](#)

BenchChem

Our mission is to be the trusted global source of essential and advanced chemicals, empowering scientists and researchers to drive progress in science and industry.

Contact

Address: 3281 E Guasti Rd
Ontario, CA 91761, United States
Phone: (601) 213-4426
Email: info@benchchem.com

[Contact our Ph.D. Support Team for a compatibility check](#)