

# Spectroscopic Analysis of Novel Thiomethylphenyl Compounds: An In-depth Technical Guide

**Author:** BenchChem Technical Support Team. **Date:** May 2026

## Compound of Interest

Compound Name:	3',4'-Dichloro-3-(2-thiomethylphenyl)propiophenone
CAS No.:	898780-52-4
Cat. No.:	B1360546

[Get Quote](#)

For Researchers, Scientists, and Drug Development Professionals

## Introduction

The incorporation of the thiomethylphenyl moiety into molecular scaffolds is a rapidly expanding strategy in medicinal chemistry and materials science. This functional group can significantly influence a compound's pharmacokinetic profile, metabolic stability, and target engagement. As novel chemical entities featuring this motif are synthesized, their comprehensive structural elucidation and characterization become paramount. Spectroscopic techniques are the cornerstone of this analytical workflow, providing detailed insights into molecular structure, purity, and conformation.<sup>[1][2]</sup>

This technical guide provides an in-depth exploration of the key spectroscopic methodologies employed in the analysis of novel thiomethylphenyl compounds. It is designed to equip researchers, scientists, and drug development professionals with the foundational knowledge and practical insights necessary to navigate the complexities of characterizing these important

molecules. We will delve into the theoretical underpinnings and practical applications of Nuclear Magnetic Resonance (NMR) spectroscopy, Mass Spectrometry (MS), Infrared (IR) spectroscopy, and Ultraviolet-Visible (UV-Vis) spectroscopy, offering a holistic approach to the structural verification of these compounds.[3][4]

## I. Nuclear Magnetic Resonance (NMR) Spectroscopy: The Gold Standard for Structural Elucidation

NMR spectroscopy is arguably the most powerful technique for the unambiguous structure determination of small organic molecules in solution.[5] It provides detailed information about the chemical environment, connectivity, and spatial arrangement of atoms within a molecule.

### A. Key Nuclei and Their Significance in Thiomethylphenyl Compounds

- $^1\text{H}$  NMR: Proton NMR is the initial and often most informative experiment. The chemical shifts, coupling constants, and integration of proton signals provide a wealth of structural information.
  - Aromatic Protons: The substitution pattern on the phenyl ring can be deduced from the chemical shifts and coupling patterns of the aromatic protons.
  - Thiomethyl Protons ( $-\text{SCH}_3$ ): A characteristic singlet peak is typically observed for the methyl protons of the thiomethyl group. Its chemical shift can be influenced by the electronic nature of the substituents on the phenyl ring.
- $^{13}\text{C}$  NMR: Carbon-13 NMR provides information on the carbon skeleton of the molecule.
  - Aromatic Carbons: The chemical shifts of the aromatic carbons are sensitive to the nature and position of substituents.
  - Thiomethyl Carbon ( $-\text{SCH}_3$ ): The resonance of the thiomethyl carbon provides a key diagnostic signal.

- $^{19}\text{F}$  and  $^{31}\text{P}$  NMR: If fluorine or phosphorus atoms are present in the molecule, their respective NMR spectra offer clean and sensitive probes for structural analysis due to their 100% natural abundance and high gyromagnetic ratios.[5]
- $^{33}\text{S}$  NMR: While less common due to the low natural abundance and quadrupolar nature of the  $^{33}\text{S}$  nucleus, advanced techniques can provide direct information about the sulfur atom's chemical environment.[6] However, for most routine analyses, its application is limited.[6]

## B. Advanced 2D NMR Techniques for Unambiguous Assignments

For complex thiomethylphenyl derivatives, one-dimensional NMR spectra can be crowded and difficult to interpret. Two-dimensional (2D) NMR experiments are indispensable for resolving overlapping signals and establishing definitive structural connectivity.

- COSY (Correlation Spectroscopy): Identifies proton-proton ( $^1\text{H}$ - $^1\text{H}$ ) spin-spin coupling networks, allowing for the tracing of proton connectivity through bonds.
- HSQC (Heteronuclear Single Quantum Coherence): Correlates directly bonded proton and carbon atoms ( $^1\text{H}$ - $^{13}\text{C}$ ), providing a powerful tool for assigning carbon resonances.
- HMBC (Heteronuclear Multiple Bond Correlation): Reveals long-range correlations between protons and carbons (typically 2-3 bonds), crucial for connecting different spin systems and establishing the overall molecular framework.
- NOESY (Nuclear Overhauser Effect Spectroscopy): Provides information about the spatial proximity of protons, which is invaluable for determining stereochemistry and conformation.

## C. Experimental Protocol: Acquiring High-Quality NMR Data

A robust and reproducible protocol is essential for obtaining high-quality NMR data.

Step-by-Step Methodology:

- Sample Preparation:

- Accurately weigh 5-10 mg of the purified thiomethylphenyl compound.[7]
- Dissolve the sample in 0.5-0.7 mL of a deuterated solvent (e.g., CDCl<sub>3</sub>, DMSO-d<sub>6</sub>, MeOD) in a clean NMR tube. The choice of solvent is critical and should be based on the compound's solubility and the desired chemical shift dispersion.[8]
- Ensure the sample is fully dissolved and the solution is homogeneous.
- Instrument Setup and Calibration:
  - Insert the sample into the NMR spectrometer.
  - Lock onto the deuterium signal of the solvent and shim the magnetic field to achieve optimal homogeneity.
  - Calibrate the spectrometer's temperature and pulse widths.[9]
- Data Acquisition:
  - Acquire a standard <sup>1</sup>H NMR spectrum to assess sample concentration and purity.
  - Acquire <sup>13</sup>C and relevant 2D NMR spectra (COSY, HSQC, HMBC) using optimized acquisition parameters.[10]
- Data Processing and Analysis:
  - Apply appropriate window functions, Fourier transform, and phase correction to the raw data.
  - Integrate the signals in the <sup>1</sup>H spectrum and determine chemical shifts relative to a reference standard (e.g., tetramethylsilane, TMS).
  - Analyze the 2D spectra to establish connectivities and assign all proton and carbon signals.

## D. Data Interpretation: A Case Study Approach

Consider a hypothetical novel thiomethylphenyl compound. The interpretation of its NMR data would follow a logical progression, starting with the identification of key functional groups from the  $^1\text{H}$  and  $^{13}\text{C}$  spectra, followed by the use of 2D NMR to piece together the molecular puzzle.

Spectroscopic Data	Interpretation
$^1\text{H}$ NMR	
$\delta$ 7.2-7.5 (m, 4H)	Aromatic protons, suggesting a disubstituted phenyl ring.
$\delta$ 2.5 (s, 3H)	Thiomethyl (-SCH <sub>3</sub> ) protons.
$^{13}\text{C}$ NMR	
$\delta$ 125-140 (4 signals)	Aromatic carbons.
$\delta$ 15.0	Thiomethyl (-SCH <sub>3</sub> ) carbon.
HSQC	Confirms the direct attachment of protons to their respective carbons.
HMBC	Shows correlations from the thiomethyl protons to the aromatic carbon attached to the sulfur atom, confirming the thiomethylphenyl moiety.

Diagram: Logical Workflow for NMR-Based Structure Elucidation

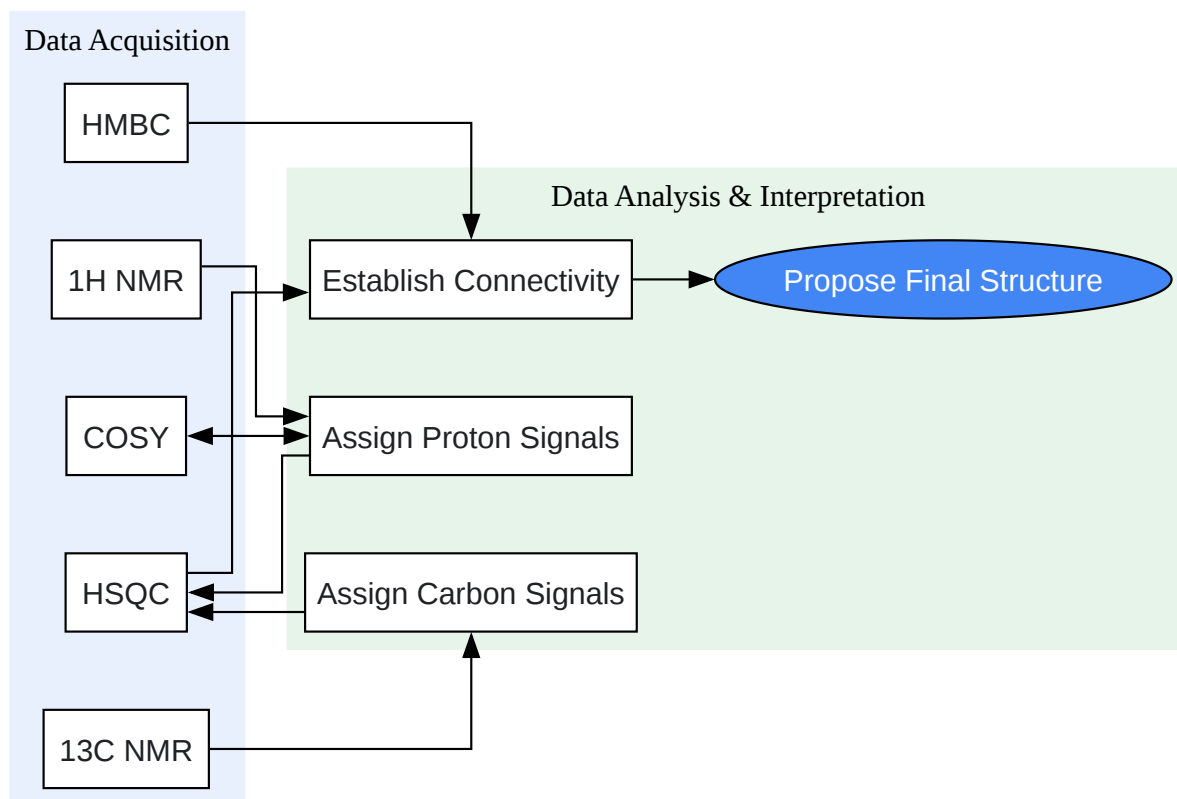

[Click to download full resolution via product page](#)

Caption: A logical workflow for the structural elucidation of novel compounds using NMR spectroscopy.

## II. Mass Spectrometry: Unveiling Molecular Weight and Fragmentation

Mass spectrometry (MS) is a powerful analytical technique that measures the mass-to-charge ratio ( $m/z$ ) of ions. It is indispensable for determining the molecular weight of a compound and providing valuable structural information through the analysis of its fragmentation patterns.

## A. Ionization Techniques for Thiomethylphenyl Compounds

The choice of ionization technique is critical and depends on the polarity and thermal stability of the analyte.

- Electron Ionization (EI): A "hard" ionization technique that often leads to extensive fragmentation. While this can make interpretation complex, the resulting fragmentation pattern is highly reproducible and can serve as a molecular fingerprint.
- Electrospray Ionization (ESI): A "soft" ionization technique ideal for polar and thermally labile molecules. It typically produces protonated molecules  $[M+H]^+$  or sodiated adducts  $[M+Na]^+$ , providing clear molecular weight information with minimal fragmentation.
- Matrix-Assisted Laser Desorption/Ionization (MALDI): Another soft ionization technique, particularly useful for high molecular weight compounds and for analyzing samples from complex matrices.

## B. High-Resolution Mass Spectrometry (HRMS) for Elemental Composition

HRMS provides highly accurate mass measurements, which can be used to determine the elemental composition of a molecule. This is a crucial step in confirming the identity of a novel compound and distinguishing it from isobaric species.

## C. Fragmentation Analysis: Gaining Structural Insights

The fragmentation patterns observed in mass spectra can provide valuable clues about the structure of a molecule. For thiomethylphenyl compounds, characteristic fragmentation pathways may involve cleavage of the C-S bond or fragmentation of the phenyl ring.

## D. Experimental Protocol: Sample Preparation and Analysis

Proper sample preparation is crucial for obtaining high-quality mass spectra.[\[11\]](#)

Step-by-Step Methodology:

- Sample Preparation:
  - Dissolve the sample in a suitable volatile solvent (e.g., methanol, acetonitrile) to a concentration of approximately 1 mg/mL.[\[12\]](#)[\[13\]](#)
  - For ESI, further dilute the sample to the low  $\mu\text{g/mL}$  or  $\text{ng/mL}$  range.
  - Filter the sample if any particulate matter is present to prevent clogging of the instrument. [\[12\]](#)
- Instrument Calibration:
  - Calibrate the mass spectrometer using a known standard to ensure accurate mass measurements.
- Data Acquisition:
  - Introduce the sample into the mass spectrometer via direct infusion or coupled with a chromatographic separation technique like liquid chromatography (LC-MS) or gas chromatography (GC-MS).
  - Acquire the mass spectrum over an appropriate  $m/z$  range.
- Data Analysis:
  - Identify the molecular ion peak to determine the molecular weight.
  - For HRMS data, use software to calculate the elemental composition.
  - Analyze the fragmentation pattern to gain structural information.

Diagram: General Workflow for Mass Spectrometry Analysis

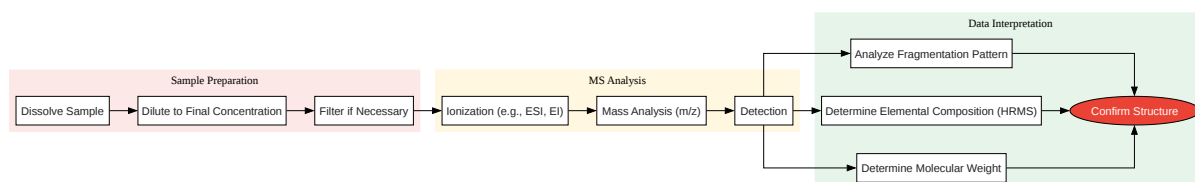

[Click to download full resolution via product page](#)

Caption: A generalized workflow for the analysis of novel compounds by mass spectrometry.

## III. Vibrational Spectroscopy: Probing Functional Groups

Infrared (IR) and Raman spectroscopy are complementary techniques that provide information about the vibrational modes of a molecule. They are particularly useful for identifying the presence of specific functional groups.

### A. Infrared (IR) Spectroscopy

IR spectroscopy measures the absorption of infrared radiation by a molecule, which causes its bonds to vibrate.<sup>[14]</sup> Different types of bonds absorb at characteristic frequencies, making IR spectroscopy a powerful tool for functional group identification.<sup>[15][16]</sup>

Key Vibrational Modes for Thiomethylphenyl Compounds:

Functional Group	Vibrational Mode	Typical Wavenumber (cm <sup>-1</sup> )
Aromatic C-H	Stretch	3100-3000
Aromatic C=C	Stretch	1600-1450
C-S	Stretch	700-600
C-H (in -SCH <sub>3</sub> )	Stretch	2950-2850

## B. Raman Spectroscopy

Raman spectroscopy is based on the inelastic scattering of monochromatic light. It provides information about vibrational modes that are Raman-active, which often complements the information obtained from IR spectroscopy. The C-S bond, for instance, often gives a strong signal in the Raman spectrum.

## C. Experimental Protocol: IR Spectroscopy (Attenuated Total Reflectance - ATR)

ATR-FTIR is a common and convenient method for obtaining IR spectra of solid and liquid samples.

Step-by-Step Methodology:

- Instrument Preparation:
  - Ensure the ATR crystal is clean.
  - Record a background spectrum.
- Sample Analysis:
  - Place a small amount of the solid sample directly onto the ATR crystal.
  - Apply pressure to ensure good contact between the sample and the crystal.
  - Collect the sample spectrum.

- Data Analysis:
  - The instrument software will automatically ratio the sample spectrum to the background spectrum to generate the final absorbance or transmittance spectrum.
  - Identify characteristic absorption bands and assign them to specific functional groups.

## IV. Ultraviolet-Visible (UV-Vis) Spectroscopy: Investigating Electronic Transitions

UV-Vis spectroscopy provides information about the electronic transitions within a molecule. [17] It is particularly useful for characterizing compounds with conjugated systems, such as the phenyl ring in thiomethylphenyl compounds.

### A. Chromophores and Electronic Transitions

The phenyl ring is the primary chromophore in thiomethylphenyl compounds, giving rise to characteristic absorption bands in the UV region. The position and intensity of these bands can be influenced by the nature and position of substituents on the ring, including the thiomethyl group.

### B. Applications in Drug Development

UV-Vis spectroscopy is widely used in drug development for quantitative analysis, such as determining the concentration of a drug substance in solution using the Beer-Lambert law. [18] It is also used in dissolution testing and for monitoring the stability of drug products.

### C. Experimental Protocol: UV-Vis Spectroscopy

Step-by-Step Methodology:

- Sample Preparation:
  - Prepare a dilute solution of the compound in a UV-transparent solvent (e.g., ethanol, methanol, acetonitrile).
  - The concentration should be chosen such that the absorbance falls within the linear range of the instrument (typically 0.1-1.0 AU).

- Instrument Setup:
  - Use a matched pair of cuvettes, one for the sample and one for the solvent blank.
  - Record a baseline spectrum with the solvent blank.
- Data Acquisition:
  - Record the UV-Vis spectrum of the sample solution over the desired wavelength range (e.g., 200-400 nm).
- Data Analysis:
  - Identify the wavelength of maximum absorbance ( $\lambda_{\text{max}}$ ).
  - Use the Beer-Lambert law ( $A = \epsilon bc$ ) to determine the molar absorptivity ( $\epsilon$ ) or to quantify the concentration of the analyte.

## V. Integrated Spectroscopic Analysis: A Holistic Approach

The true power of spectroscopic analysis lies in the integration of data from multiple techniques. Each method provides a unique piece of the structural puzzle, and together they allow for the confident and unambiguous characterization of novel thiomethylphenyl compounds.

Diagram: Integrated Spectroscopic Analysis Workflow

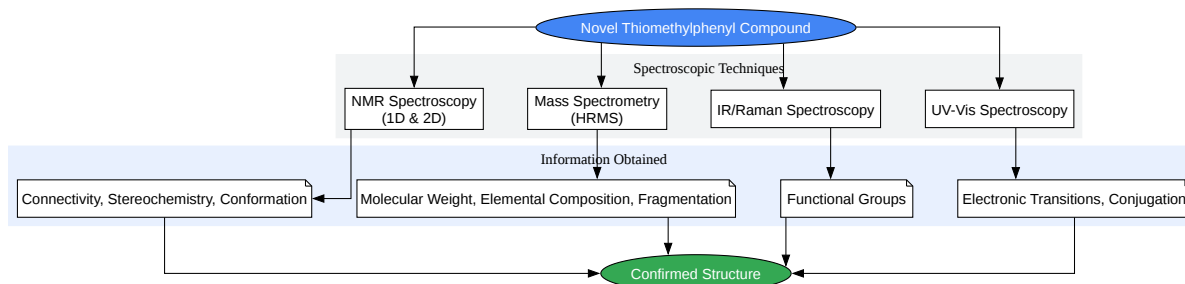

[Click to download full resolution via product page](#)

Caption: An integrated workflow demonstrating how multiple spectroscopic techniques contribute to the final structural confirmation.

## VI. Conclusion

The spectroscopic analysis of novel thiomethylphenyl compounds is a multifaceted process that requires a combination of techniques and a deep understanding of their theoretical principles and practical applications. This guide has provided a comprehensive overview of the key spectroscopic methodologies, from the unparalleled structural detail offered by NMR to the crucial molecular weight information from MS, and the functional group identification provided by IR and UV-Vis spectroscopy. By adopting an integrated approach and following robust experimental protocols, researchers can confidently elucidate the structures of these important molecules, paving the way for their further development in the fields of medicine and materials science.

## References

- Vertex AI Search. (n.d.). Spectroscopic technique: Significance and symbolism.

- AZoLifeSciences. (2023, November 7). NMR Spectroscopy in Structural Analysis of Organic Compounds.
- PubMed Central. (2021, March 7). Spectroscopic Study of the Molecular Structure of the New Hybrid with a Potential Two-Way Antibacterial Effect.
- MDPI. (n.d.). 33S NMR: Recent Advances and Applications.
- Longdom Publishing. (n.d.). Pharmaceutical Development and the Applications of Spectroscopy in Biopharmaceutical Identification.
- Compound Interest. (2015, February 5). Analytical Chemistry – Infrared (IR) Spectroscopy.
- ResearchGate. (2010, January 16). Analysis of organometallic compounds: Spectroscopic methods.
- MDPI. (n.d.). Metal Electrochemical Sensing over LASIS Gold Nanoparticle-Modified Screen-Printed Carbon Electrodes in Adsorption Studies with Waste Biomass-Derived Highly Porous Carbon Material.
- Books Gateway. (2025, December 3). NMR spectroscopy of small molecules in solution | Nuclear Magnetic Resonance Volume 51.
- ChemAxon. (2020, September 12). Following the oxidation state of organosulfur compounds with NMR: Experimental data versus DFT calculations and database-powered NMR prediction.
- (n.d.). NMR sample preparation guidelines.
- Hans Reich NMR Collection. (2020, February 14). NMR Spectroscopy :: Content - Organic Chemistry Data.
- PMC - NIH. (2025, August 29). Solvent-driven spectroscopic and quantum chemical evaluation of 2-[(trimethylsilyl) ethynyl]thiophene with molecular docking insights.
- ResearchGate. (2025, August 6). Synthesis of and characterization of some Heterocyclic Compounds derived from Thiophenol.
- ManTech Publications. (n.d.). Advanced Spectroscopic Techniques in Pharmaceutical Analysis: A Critical Evaluation.
- PMC - NIH. (n.d.). Efficient NMR Screening Approach to Discover Small Molecule Fragments Binding Structured RNA.
- Chemistry LibreTexts. (2025, January 1). 12.8: Infrared Spectra of Some Common Functional Groups.
- Organomation. (n.d.). Mass Spectrometry Sample Preparation Guide.
- ResearchGate. (n.d.). STUDIES IN THE HETEROCYCLIC COMPOUNDS: II. THE MASS SPECTRA OF SOME THIOPHENE-SULFONYL DERIVATIVES | Request PDF.
- Journal of the American Chemical Society. (n.d.). Useful approach for determination of the structure of organosulfur compounds: sulfur-33 high-resolution FT-NMR.
- IEEE Xplore. (n.d.). 13 Role of spectroscopy in drug discovery.
- Specac Ltd. (n.d.). Interpreting Infrared Spectra.

- (2025, August 7). Qualitatively Incorrect Features in the TDDFT Spectrum of Thiophene-Based Compounds.
- Mass Spectrometry Research Facility. (n.d.). Sample Preparation Protocol for Open Access MS.
- KU Leuven. (n.d.). Protonation and methylation of thiophenol, thioanisole and their halogenated derivatives: mass spectrometric and computational.
- (2024, October 5). Innovations in Drug Spectroscopy Methods for Pharmaceutical Compounds.
- SciSpace. (n.d.). Spectroscopic Techniques.
- Simson Pharma Limited. (2025, July 19). The Role of Spectroscopy in Modern Pharmaceutical Industry.
- ResearchGate. (n.d.). Analytical advances and challenges for the determination of heterocyclic aromatic compounds (NSO-HET) in sediment: A review | Request PDF.
- Wikipedia. (n.d.). Sample preparation in mass spectrometry.
- PubMed. (2020, March). MASS SPECTROMETRIC FRAGMENTATION OF TRIMETHYLSILYL AND RELATED ALKYL SILYL DERIVATIVES.
- (n.d.). INFRARED SPECTROSCOPY (IR).
- MDPI. (n.d.). Synthesis, Spectroscopic Characterization, and Biological Evaluation of a Novel Acyclic Heterocyclic Compound: Anticancer, Antioxidant, Antifungal, and Molecular Docking Studies.
- science-softCon. (n.d.). UV/Vis + Photochemistry Database.
- Books Gateway. (2024, November 15). NMR spectroscopy of small molecules in solution | Nuclear Magnetic Resonance Volume 50.
- SCION Instruments. (n.d.). Sample preparation GC-MS.
- ResearchGate. (2025, July 9). Initial Discovery and Characterization of Novel Spirotriazoloquinazolines as Potential Neuroprotectors: Synthesis, Computational Screening, and Preliminary In Vivo Evaluation.
- (2016, September 16). What is UV-Vis Spectroscopy? And How Does It Apply To Conjugation?.
- Springer Nature Experiments. (n.d.). NMR Protocols and Methods.
- Refubium - Freie Universität Berlin. (n.d.). Mass Spectrometry of Drug Derivatives: A Contribution to the Characterization of Fragmentation Reactions by Labelling with Stable.
- MDPI. (2023, July 26). Special Issue "Advanced Spectroscopy Techniques in Food Analysis: Qualitative and Quantitative Chemometric Approaches".
- (2023, October 20). How to Read and Interpret the IR Spectra | Step-by-Step Guide to IR Spectroscopy.
- ResearchGate. (2019, December 5). MASS SPECTROMETRIC FRAGMENTATION OF TRIMETHYLSILYL AND RELATED ALKYL SILYL DERIVATIVES | Request PDF.

- (n.d.). Advances in Analytical Techniques for Drug Discovery and Development.
- Harvard Center for Mass Spectrometry. (n.d.). Sample Preparation.
- University of Pretoria. (n.d.). CHAPTER 4 UV/VIS SPECTROSCOPY.
- Chemistry LibreTexts. (2022, October 4). 2.3: UV-Visible Spectroscopy of Organic Compounds.

### Need Custom Synthesis?

BenchChem offers custom synthesis for rare earth carbides and specific isotopic labeling.

Email: [info@benchchem.com](mailto:info@benchchem.com) or [Request Quote Online](#).

## Sources

1. [longdom.org](http://longdom.org) [[longdom.org](http://longdom.org)]
2. 13 Role of spectroscopy in drug discovery | part of Computational Drug Discovery: Molecular Simulation for Medicinal Chemistry | De Gruyter books | IEEE Xplore [[ieeexplore.ieee.org](http://ieeexplore.ieee.org)]
3. Spectroscopic technique: Significance and symbolism [[wisdomlib.org](http://wisdomlib.org)]
4. Spectroscopic Study of the Molecular Structure of the New Hybrid with a Potential Two-Way Antibacterial Effect - PMC [[pmc.ncbi.nlm.nih.gov](http://pmc.ncbi.nlm.nih.gov)]
5. [azolifesciences.com](http://azolifesciences.com) [[azolifesciences.com](http://azolifesciences.com)]
6. [mdpi.com](http://mdpi.com) [[mdpi.com](http://mdpi.com)]
7. [nmr-bio.com](http://nmr-bio.com) [[nmr-bio.com](http://nmr-bio.com)]
8. NMR Protocols and Methods | Springer Nature Experiments [[experiments.springernature.com](http://experiments.springernature.com)]
9. [books.rsc.org](http://books.rsc.org) [[books.rsc.org](http://books.rsc.org)]
10. [books.rsc.org](http://books.rsc.org) [[books.rsc.org](http://books.rsc.org)]
11. Sample Preparation | Harvard Center for Mass Spectrometry [[massspec.fas.harvard.edu](http://massspec.fas.harvard.edu)]
12. Sample Preparation Protocol for Open Access MS | Mass Spectrometry Research Facility [[massspec.chem.ox.ac.uk](http://massspec.chem.ox.ac.uk)]
13. Sample preparation GC-MS [[scioninstruments.com](http://scioninstruments.com)]
14. [compoundchem.com](http://compoundchem.com) [[compoundchem.com](http://compoundchem.com)]

- [15. chem.libretexts.org \[chem.libretexts.org\]](https://chem.libretexts.org)
- [16. Interpreting Infrared Spectra - Specac Ltd \[specac.com\]](https://www.specac.com)
- [17. repository.up.ac.za \[repository.up.ac.za\]](https://repository.up.ac.za)
- [18. mdpi.com \[mdpi.com\]](https://www.mdpi.com)
- To cite this document: BenchChem. [Spectroscopic Analysis of Novel Thiomethylphenyl Compounds: An In-depth Technical Guide]. BenchChem, [2026]. [Online PDF]. Available at: [<https://www.benchchem.com/product/b1360546/docs#spectroscopic-analysis-of-novel-thiomethylphenyl-compounds-an-in-depth-technical-guide>]

---

### Disclaimer & Data Validity:

The information provided in this document is for Research Use Only (RUO) and is strictly not intended for diagnostic or therapeutic procedures. While BenchChem strives to provide accurate protocols, we make no warranties, express or implied, regarding the fitness of this product for every specific experimental setup.

**Technical Support:** The protocols provided are for reference purposes. Unsure if this reagent suits your experiment?

**Need Industrial/Bulk Grade?** [Request Custom Synthesis Quote](#)

## BenchChem

Our mission is to be the trusted global source of essential and advanced chemicals, empowering scientists and researchers to drive progress in science and industry.

### Contact

Address: 3281 E Guasti Rd  
Ontario, CA 91761, United States  
Phone: (601) 213-4426  
Email: [info@benchchem.com](mailto:info@benchchem.com)

[Contact our Ph.D. Support Team for a compatibility check](#)

