

# Application Note: TLC Monitoring of 3-(4-Chlorophenoxy)propanenitrile Synthesis

**Author:** BenchChem Technical Support Team. **Date:** May 2026

## Compound of Interest

Compound Name: 3-(4-Chlorophenoxy)propanenitrile

CAS No.: 46125-42-2

Cat. No.: B1360037

[Get Quote](#)

## Abstract & Introduction

This application note details the protocol for monitoring the synthesis of **3-(4-Chlorophenoxy)propanenitrile** (CAS: 32450-46-3) using Thin Layer Chromatography (TLC). This compound is a critical intermediate in the synthesis of various pharmaceutical agents (e.g., chroman derivatives) and agrochemicals.

The synthesis typically proceeds via the cyanoethylation of 4-chlorophenol with acrylonitrile (Michael addition) or via nucleophilic substitution using 3-bromopropanenitrile.<sup>[1]</sup> Regardless of the route, the conversion involves the transformation of a polar phenolic hydroxyl group into a less acidic ether-nitrile moiety. This significant change in polarity makes TLC an ideal, rapid, and cost-effective method for monitoring reaction completeness.

## Chemical Reaction & Mechanism

To accurately interpret TLC data, one must understand the species present in the reaction matrix.

## Primary Synthesis Route: Cyanoethylation (Michael Addition)

- Reactants: 4-Chlorophenol (Limiting Reagent), Acrylonitrile (Excess/Solvent).
- Catalyst: Triton B (Benzyltrimethylammonium hydroxide) or Sodium Methoxide.
- Product: **3-(4-Chlorophenoxy)propanenitrile**.[\[1\]](#)

## Secondary Route: Nucleophilic Substitution (Williamson Ether Synthesis)

- Reactants: 4-Chlorophenol, 3-Bromopropanenitrile.[\[1\]](#)
- Base: Potassium Carbonate (  
  
).[\[2\]](#)

### Chromatographic Logic:

- 4-Chlorophenol (Starting Material - SM): Contains a free phenolic hydroxyl (-OH) group.[\[1\]](#) It acts as a hydrogen bond donor, interacting strongly with the silanol groups of the silica stationary phase. Expected Rf: Lower.
- **3-(4-Chlorophenoxy)propanenitrile** (Product - P): The hydroxyl group is capped (ether linkage).[\[1\]](#) While the nitrile group (-CN) is polar, it lacks the strong hydrogen bond donor capability of the phenol. Consequently, it interacts less retentionally with silica than the phenol. Expected Rf: Higher.

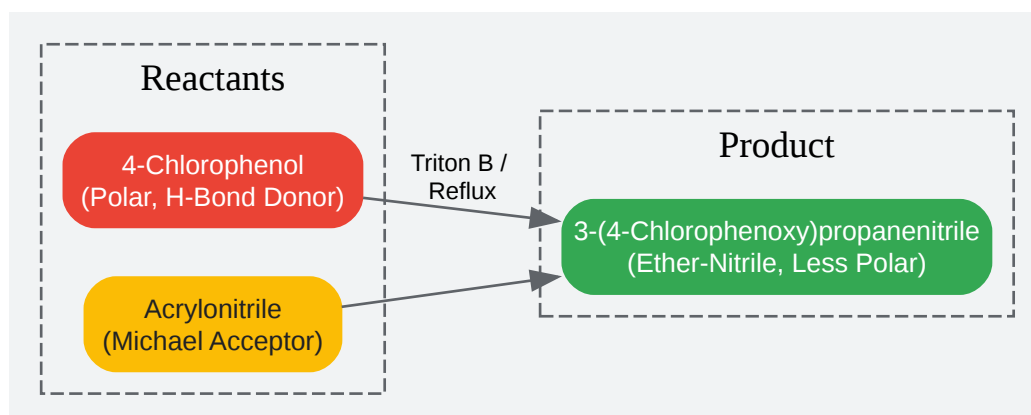

[Click to download full resolution via product page](#)

Figure 1: Reaction scheme highlighting the polarity shift monitored by TLC.[1]

## Materials & Equipment

### Stationary Phase

- Plates: Silica Gel 60

on aluminum or glass backing (20 x 20 cm or precut).

- Why

? Both the starting material and product contain an aromatic ring (4-chlorophenyl moiety), which strongly absorbs UV light at 254 nm. This allows for non-destructive visualization.

### Mobile Phase Optimization

- Standard System: Hexane : Ethyl Acetate (Hex:EtOAc).
- Recommended Ratio: Start with 70:30 (v/v).
  - If SM does not move: Increase polarity to 60:40.
  - If separation is poor:[1] Decrease polarity to 80:20.

### Reagents

- Solvent for Sampling: Ethyl Acetate or Dichloromethane (DCM).
- Stain (Optional): Iodine (  
  
) chamber (general organic stain) or  
  
(oxidizes phenols). Note: UV is usually sufficient.[1]

## Experimental Protocol

### Step 1: Reaction Sampling[3]

- Safety: Acrylonitrile is toxic and volatile.[3][4] Perform all sampling in a fume hood.
- Using a glass capillary or micropipette, withdraw ~10 L of the reaction mixture.
- Dilute the aliquot into 0.5 mL of Ethyl Acetate in a small vial.
  - Why? Direct spotting of concentrated reaction mixtures can overload the plate, causing "tailing" and poor separation.

## Step 2: Plate Preparation & Spotting

- Cut a TLC plate to approx. 2 cm x 6 cm.
- Draw a pencil line (origin) 1 cm from the bottom.[5]
- Spotting Strategy (3-Lane Method):
  - Lane 1 (SM): Pure 4-Chlorophenol reference (dissolved in EtOAc).[1]
  - Lane 2 (Co-Spot): Overlapping spot of SM + Reaction Mixture. Crucial for detecting co-elution.[1]
  - Lane 3 (Rxn): Diluted Reaction Mixture.

## Step 3: Development

- Place 5-10 mL of the Mobile Phase (Hex:EtOAc 70:30) in a developing chamber.
- Insert the plate. Ensure the solvent level is below the origin line.
- Allow the solvent front to migrate until it is ~1 cm from the top.
- Remove the plate and immediately mark the solvent front with a pencil.

## Step 4: Visualization & Analysis

- Dry: Air dry the plate in the fume hood to remove solvents.

- UV Lamp (254 nm): Observe dark spots against the bright green fluorescent background.
- Calculate Rf:

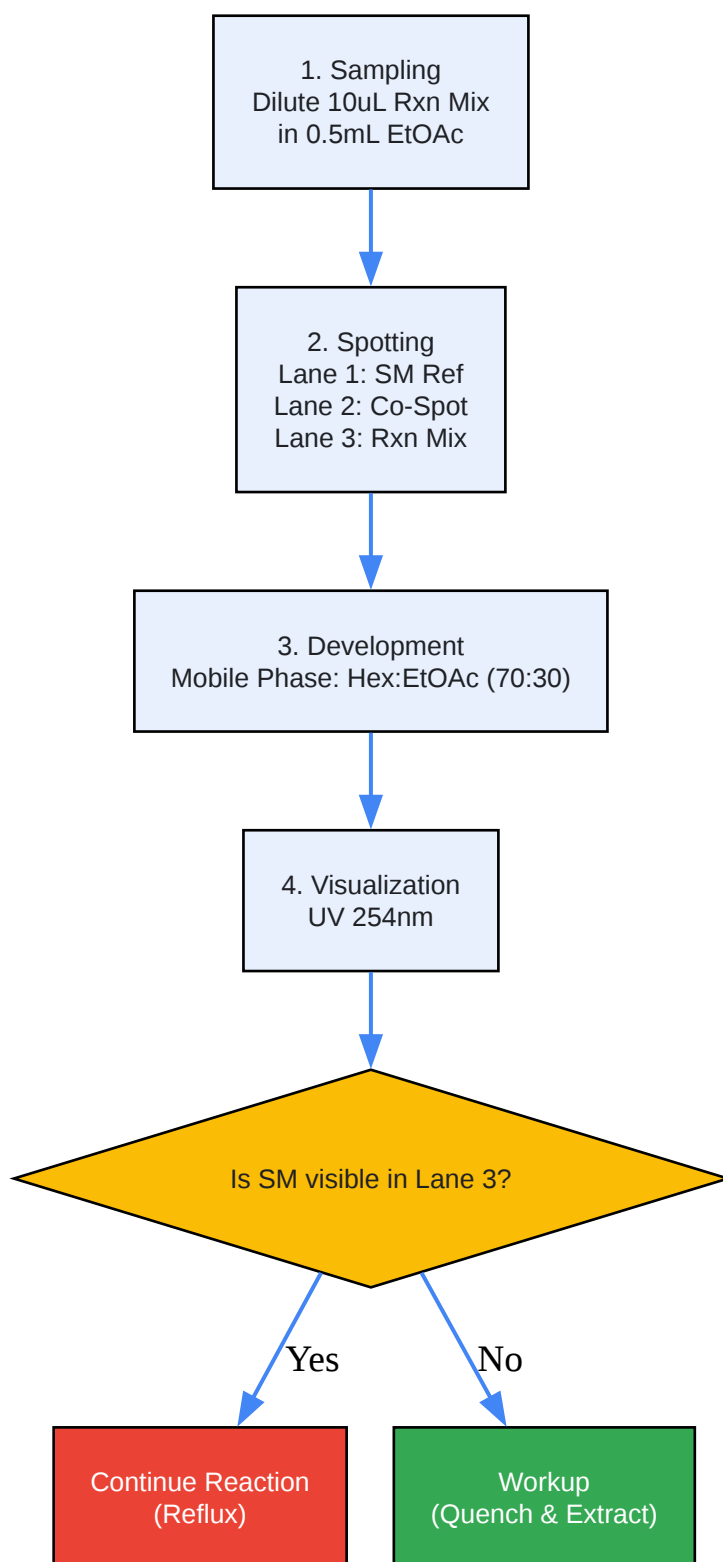

[Click to download full resolution via product page](#)

Figure 2: Step-by-step workflow for TLC monitoring and decision making.

## Data Interpretation & Troubleshooting

### Expected Results (Hexane:EtOAc 70:30)

Compound	Functional Group	Polarity	Expected Rf	Visualization
4-Chlorophenol (SM)	Phenol (-OH)	High	0.25 - 0.35	UV (Dark Spot)
Product	Ether / Nitrile	Medium	0.50 - 0.60	UV (Dark Spot)
Acrylonitrile	Nitrile / Alkene	Medium	Volatile	Not visible (Evaporates)

### Troubleshooting Guide

Observation	Diagnosis	Solution
Streaking / Tailing	Sample too concentrated or acidic SM interaction with silica.[1]	Dilute sample further. Add 1% Acetic Acid to mobile phase to sharpen phenol spots.
No Separation (Co-elution)	Mobile phase too polar.	Change solvent system to Hexane:EtOAc 85:15 or use Toluene:EtOAc.[1]
New Spot at Origin	Formation of salt (Phenoxide) or polymer.	Quench the TLC sample aliquot with dilute HCl before spotting to convert phenoxide back to phenol.
Product Spot Faint	Low conversion or low UV activity (unlikely for this aromatic).	Check reaction temperature/catalyst.[2] Ensure UV lamp is functioning.

## Safety Considerations (Critical)

- Acrylonitrile: A potent carcinogen, highly flammable, and volatile.[3] It can be absorbed through the skin. Double-gloving (Nitrile) and working in a high-efficiency fume hood are mandatory.[1]
- Waste Disposal: All TLC solvents and capillaries containing acrylonitrile residues must be disposed of in segregated hazardous waste containers (P-listed waste protocols often apply).[1]

## References

- Vogel, A. I. Vogel's Textbook of Practical Organic Chemistry, 5th Ed. Longman Scientific & Technical, 1989. (General reference for cyanoethylation and TLC techniques).
- BenchChem. Synthesis of 3-(4-Chlorophenoxy)phthalonitrile (Analogous chemistry demonstrating nucleophilic substitution and TLC monitoring). Retrieved from BenchChem Application Notes.
- National Center for Biotechnology Information. PubChem Compound Summary for CID 7843, Acrylonitrile. (Safety and Reactivity Data).
- Reich, H. J. Bordwell pKa Table (Acidity in DMSO). University of Wisconsin-Madison.[1] (Reference for relative acidity of phenols vs nitriles determining silica interaction).

### Need Custom Synthesis?

BenchChem offers custom synthesis for rare earth carbides and specific isotopic labeling.

Email: [info@benchchem.com](mailto:info@benchchem.com) or [Request Quote Online](#).

## Sources

- 1. [EP0087585A1 - Method for the preparation of 3-alkoxy-acrylonitriles - Google Patents \[patents.google.com\]](#)
- 2. [pdf.benchchem.com \[pdf.benchchem.com\]](#)
- 3. [petrochemistry.eu \[petrochemistry.eu\]](#)

- [4. 5169e6bcd4855faee180-7b63e7a7d0a4b0cdc26f4a866f0e35fa.ssl.cf3.rackcdn.com](https://5169e6bcd4855faee180-7b63e7a7d0a4b0cdc26f4a866f0e35fa.ssl.cf3.rackcdn.com) [[5169e6bcd4855faee180-7b63e7a7d0a4b0cdc26f4a866f0e35fa.ssl.cf3.rackcdn.com](https://5169e6bcd4855faee180-7b63e7a7d0a4b0cdc26f4a866f0e35fa.ssl.cf3.rackcdn.com)]
- [5. faculty.ksu.edu.sa](https://faculty.ksu.edu.sa) [[faculty.ksu.edu.sa](https://faculty.ksu.edu.sa)]
- To cite this document: BenchChem. [Application Note: TLC Monitoring of 3-(4-Chlorophenoxy)propanenitrile Synthesis]. BenchChem, [2026]. [Online PDF]. Available at: [<https://www.benchchem.com/product/b1360037/docs#application-note-tlc-monitoring-of-3-4-chlorophenoxy-propanenitrile-synthesis>]

### Disclaimer & Data Validity:

The information provided in this document is for Research Use Only (RUO) and is strictly not intended for diagnostic or therapeutic procedures. While BenchChem strives to provide accurate protocols, we make no warranties, express or implied, regarding the fitness of this product for every specific experimental setup.

**Technical Support:** The protocols provided are for reference purposes. Unsure if this reagent suits your experiment?

**Need Industrial/Bulk Grade?** [Request Custom Synthesis Quote](#)

## BenchChem

Our mission is to be the trusted global source of essential and advanced chemicals, empowering scientists and researchers to drive progress in science and industry.

### Contact

Address: 3281 E Guasti Rd  
Ontario, CA 91761, United States  
Phone: (601) 213-4426  
Email: [info@benchchem.com](mailto:info@benchchem.com)

[Contact our Ph.D. Support Team for a compatibility check](#)

