

Application Note: Catalytic Synthesis of N-Aryl Carbamates

Author: BenchChem Technical Support Team. **Date:** May 2026

Compound of Interest

Compound Name: Ethyl *m*-trifluoromethylcarbanilate

CAS No.: 2354-93-0

Cat. No.: B1360254

[Get Quote](#)

Executive Summary

N-aryl carbamates are critical structural motifs in agrochemicals, pharmaceuticals (e.g., retigabine), and polymer chemistry (polyurethane precursors). Historically, their synthesis relied on the phosgenation of amines—a process burdened by extreme toxicity and corrosive byproducts (HCl).[1]

This guide details three catalytic protocols that circumvent phosgene, utilizing Carbon Monoxide (CO) or Carbon Dioxide (

) as C1 sources. These methods represent the transition from stoichiometric, hazardous chemistry to atom-economical, catalytic manufacturing.

Method A: Reductive Carbonylation of Nitroarenes

Best for: Large-scale production, industrial precursors, and avoiding amine handling. Carbon

Source: CO Catalyst System: Palladium(II) / 1,10-Phenanthroline[2]

Principle & Mechanism

This reaction converts nitroarenes directly to carbamates, bypassing the aniline intermediate. The mechanism is complex, involving the reduction of the nitro group to a nitroso intermediate, which interacts with the Pd center. The active catalytic species is often a Pd(0) complex generated in situ.[3]

Key Mechanistic Steps:

- Reduction:

is deoxygenated by CO to form nitrosoarene ().
- Complexation: Coordination of

to the metal center.
- Carbonylation: Formation of a metallacyclic intermediate.
- Alcoholysis: Nucleophilic attack by alcohol (ROH) to release the carbamate.

Mechanistic Visualization

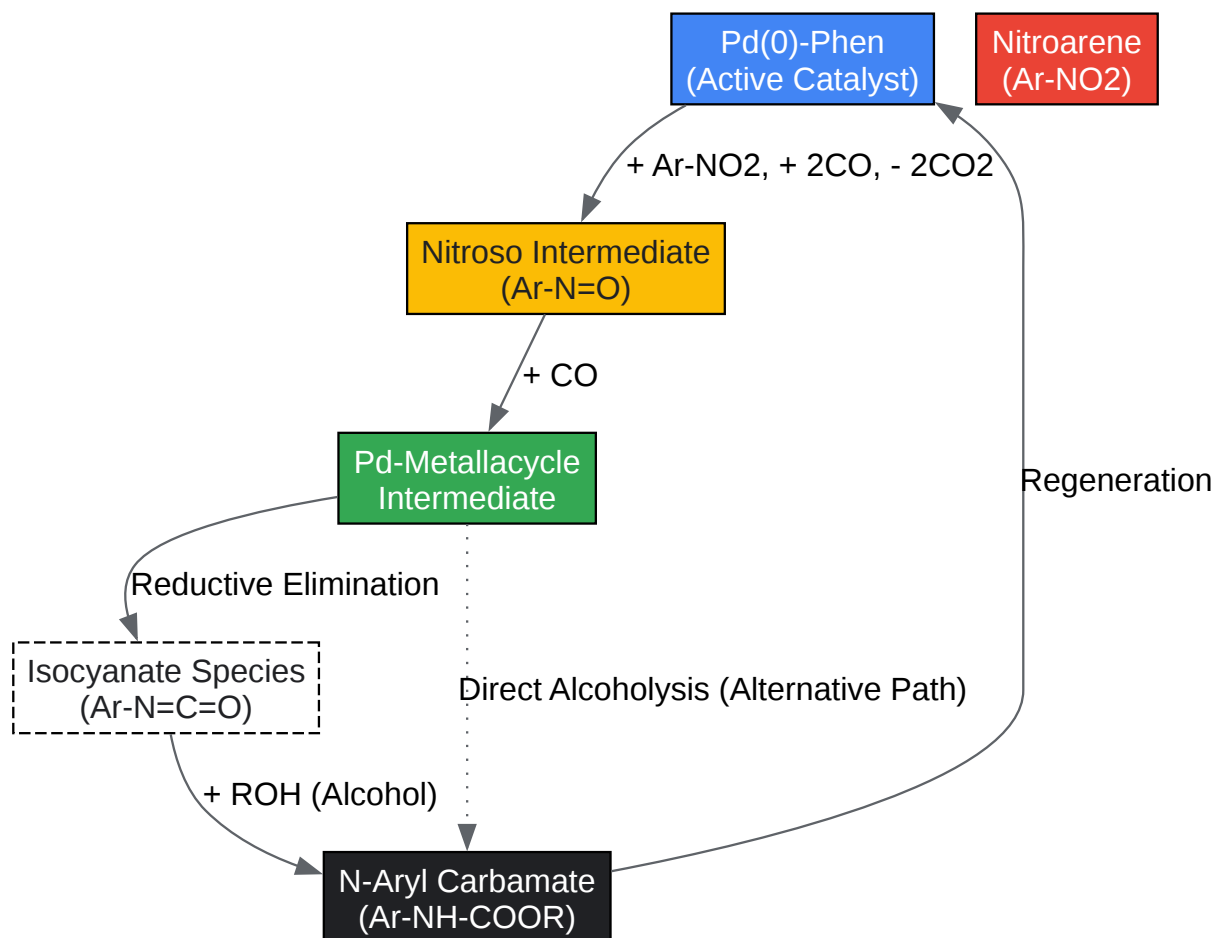

[Click to download full resolution via product page](#)

Figure 1: Catalytic cycle for the reductive carbonylation of nitroarenes mediated by Palladium-Phenanthroline complexes.

Experimental Protocol

Target: Synthesis of Methyl N-phenylcarbamate from Nitrobenzene.

Reagents:

- Nitrobenzene (1.0 mmol)
- Methanol (5 mL, anhydrous)

- Catalyst:

(1 mol%)
- Promoter: 2,4,6-Trimethylbenzoic acid (10 mol%) - Acidic promoters stabilize the active species.
- Gas: Carbon Monoxide (CO)

Step-by-Step Procedure:

- Safety Check: Ensure the high-pressure autoclave is rated for 80+ bar. CO is odorless and lethal; work in a well-ventilated hood with CO detectors active.
- Loading: In a glovebox or under Argon, load the Teflon liner of the autoclave with Nitrobenzene, Methanol,

, and the acid promoter.
- Purging: Seal the autoclave. Purge three times with CO (pressurize to 5 bar, then vent) to remove oxygen.
- Pressurization: Pressurize the reactor to 40–60 bar with CO.
- Reaction: Heat the reactor to 140°C. Stir magnetically at 800 rpm for 5–10 hours.
- Workup: Cool to room temperature. Carefully vent the unreacted CO into a scrubber system.
- Analysis: Filter the catalyst. Analyze the filtrate by GC-MS. Purify via flash chromatography (Hexane/EtOAc) if isolation is required.

Critical Parameter: Water tolerance is low. Moisture can hydrolyze the intermediate isocyanate to urea byproducts. Use anhydrous methanol.

Method B: Oxidative Carbonylation of Amines

Best for: Laboratory synthesis, utilizing available amines. Carbon Source: CO +

(Oxidant) Catalyst System: Palladium(II) Iodide / Potassium Iodide

Principle

This method couples an amine, CO, and an alcohol.^{[4][5][6][7]} Unlike the reductive method, this requires an oxidant to regenerate the Pd(II) species from Pd(0).

Reaction:

Experimental Protocol

Target: Synthesis of Ethyl N-phenylcarbamate.

Reagents:

- Aniline (2.0 mmol)
- Ethanol (10 mL)
- Catalyst:
(0.5 mol%)
- Promoter: KI (5 mol%)
- Gases: CO and Air (or synthetic air: 80%
, 20%
)

Step-by-Step Procedure:

- Loading: Charge a stainless steel autoclave with Aniline, Ethanol,
, and KI.
- Gas Mixture: Pressurize with CO (20 bar) and Air (5 bar). Warning: Ensure the gas mixture stays outside the explosion limits of CO/Oxygen.
- Reaction: Heat to 100°C for 3 hours.

- Workup: Vent gases. The product often crystallizes upon cooling or concentration.
- Purification: Recrystallize from EtOH/Water or perform silica column chromatography.

Method C: Fixation (The "Green" Route)

Best for: Sustainability, avoiding CO toxicity, and mild conditions.[8][9] Carbon Source:

(Carbon Dioxide) Catalyst/Base: Cesium Carbonate (

) / TBAI

Principle

Direct reaction of amines with CO_2 is thermodynamically limited. To drive the reaction, an electrophile (alkyl halide) is added to trap the intermediate carbamate anion. This is a three-component coupling: Amine +

CO_2 + Alkyl Halide.[10]

Pathway Visualization

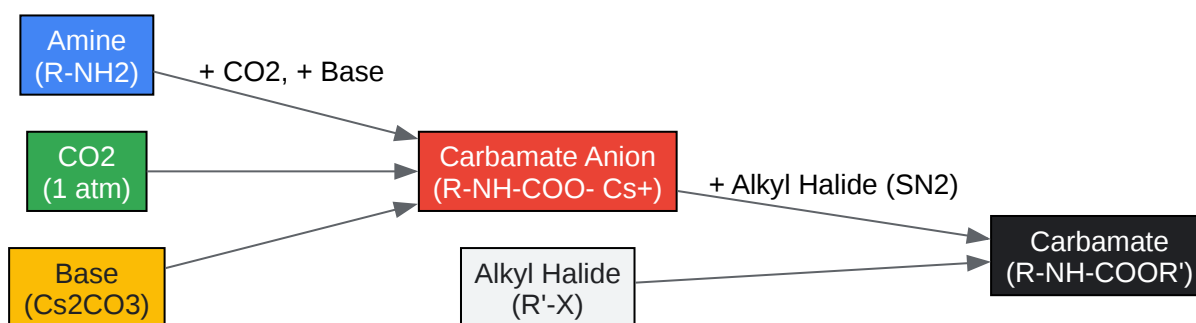

[Click to download full resolution via product page](#)

Figure 2: Cesium carbonate-mediated three-component coupling of amines, CO₂, and alkyl halides.[10][11]

Experimental Protocol

Target: Synthesis of Butyl N-phenylcarbamate.

Reagents:

- Aniline (1.0 mmol)[8][12]
- Cesium Carbonate (
, 2.0 mmol)
- Tetrabutylammonium iodide (TBAI, 0.2 mmol) - Phase transfer catalyst.
- Butyl bromide (1.2 mmol)
- Solvent: DMF (5 mL)
- Gas:
(Balloon)

Step-by-Step Procedure:

- Setup: Flame-dry a round-bottom flask and equip it with a magnetic stir bar.
- Reagent Addition: Add
, TBAI, and DMF. Stir vigorously.
- Amine Addition: Add Aniline.
- Introduction: Purge the flask with
and attach a
balloon (approx. 1 atm). Stir for 30 minutes at Room Temperature (RT) to allow the carbamate salt to form.
- Electrophile Addition: Add Butyl bromide via syringe.
- Reaction: Heat to 60°C and stir for 4–6 hours.

- Workup: Quench with water (20 mL). Extract with Ethyl Acetate (3 x 15 mL). Wash organic layer with brine.
- Analysis: Dry over

, concentrate, and analyze by NMR.

Comparative Analysis

Feature	Method A (Reductive)	Method B (Oxidative)	Method C (Fixation)
Substrate	Nitroarenes	Amines	Amines
C1 Source	CO (Toxic)	CO (Toxic)	(Green/Safe)
Atom Economy	Moderate (loses)	High (produces)	High (salt byproduct)
Pressure	High (40-60 bar)	Medium (20-30 bar)	Atmospheric (Balloon)
Safety Profile	High Risk (CO leak)	High Risk (Explosion limit)	Excellent
Scalability	Industrial Standard	Lab/Pilot	Lab/Fine Chemical

References

- Reductive Carbonylation Mechanism & Catalysts
 - Ragaini, F., & Cenini, S. (1999). Palladium-Phenanthroline Catalyzed Carbonylation Reactions of Nitroarenes. *Organometallics*.
- Oxidative Carbonylation Protocols
 - Chaudhari, R. V., et al. (2010).^[13] Immobilized Palladium Nanoparticles Catalyzed Oxidative Carbonylation of Amines. *Ind. Eng. Chem. Res.*
- CO₂ Fixation (Three-Component Coupling)

- Salvatore, R. N., et al. (2001).[10] Efficient Carbamate Synthesis via a Three-Component Coupling of an Amine, CO₂, and Alkyl Halides. J. Org.[4][5][10] Chem.
- Continuous Flow CO₂ Methods
 - Borbás, K., et al. (2023).[8] Continuous Synthesis of Carbamates from CO₂ and Amines. ACS Omega.[8]
- General Review on Carbamate Synthesis
 - Organic Chemistry Portal. Carbamate Synthesis.

Need Custom Synthesis?

BenchChem offers custom synthesis for rare earth carbides and specific isotopic labeling.

Email: info@benchchem.com or [Request Quote Online](#).

Sources

- [1. taylorfrancis.com](https://www.taylorfrancis.com) [[taylorfrancis.com](https://www.taylorfrancis.com)]
- [2. ukessays.com](https://www.ukessays.com) [[ukessays.com](https://www.ukessays.com)]
- [3. mdpi.com](https://www.mdpi.com) [[mdpi.com](https://www.mdpi.com)]
- [4. Carbamate synthesis by carbamoylation](https://www.organic-chemistry.org) [[organic-chemistry.org](https://www.organic-chemistry.org)]
- [5. pubs.acs.org](https://pubs.acs.org) [pubs.acs.org]
- [6. Carbon dioxide-based facile synthesis of cyclic carbamates from amino alcohols - Chemical Communications \(RSC Publishing\)](https://pubs.rsc.org) [pubs.rsc.org]
- [7. pubs.acs.org](https://pubs.acs.org) [pubs.acs.org]
- [8. Continuous Synthesis of Carbamates from CO₂ and Amines - PMC](https://pubmed.ncbi.nlm.nih.gov) [[pmc.ncbi.nlm.nih.gov](https://pubmed.ncbi.nlm.nih.gov)]
- [9. Amide synthesis by aminocarbonylation](https://www.organic-chemistry.org) [[organic-chemistry.org](https://www.organic-chemistry.org)]
- [10. Carbamate synthesis by amination \(carboxylation\) or rearrangement](https://www.organic-chemistry.org) [[organic-chemistry.org](https://www.organic-chemistry.org)]
- [11. Advances in Palladium-Catalyzed Carboxylation Reactions - PMC](https://pubmed.ncbi.nlm.nih.gov) [[pmc.ncbi.nlm.nih.gov](https://pubmed.ncbi.nlm.nih.gov)]
- [12. pubs.acs.org](https://pubs.acs.org) [pubs.acs.org]

- [13. pubs.acs.org \[pubs.acs.org\]](https://pubs.acs.org)
- To cite this document: BenchChem. [Application Note: Catalytic Synthesis of N-Aryl Carbamates]. BenchChem, [2026]. [Online PDF]. Available at: [<https://www.benchchem.com/product/b1360254/docs#application-note-catalytic-synthesis-of-n-aryl-carbamates>]

Disclaimer & Data Validity:

The information provided in this document is for Research Use Only (RUO) and is strictly not intended for diagnostic or therapeutic procedures. While BenchChem strives to provide accurate protocols, we make no warranties, express or implied, regarding the fitness of this product for every specific experimental setup.

Technical Support: The protocols provided are for reference purposes. Unsure if this reagent suits your experiment?

Need Industrial/Bulk Grade? [Request Custom Synthesis Quote](#)

BenchChem

Our mission is to be the trusted global source of essential and advanced chemicals, empowering scientists and researchers to drive progress in science and industry.

Contact

Address: 3281 E Guasti Rd
Ontario, CA 91761, United States
Phone: (601) 213-4426
Email: info@benchchem.com

[Contact our Ph.D. Support Team for a compatibility check](#)