

Using 4-aminonaphthoxyacetic acid as a fluorescent linker

Author: BenchChem Technical Support Team. **Date:** May 2026

Compound of Interest

Compound Name: 2-((4-Aminonaphthalen-1-yl)oxy)acetic acid

Cat. No.: B13597245

[Get Quote](#)

Abstract & Introduction

The "Active" Linker Paradigm In the landscape of antibody-drug conjugates (ADCs) and proteomic probes, linkers have traditionally been viewed as passive structural bridges—silent spacers designed solely to connect a targeting moiety to a payload. 4-aminonaphthoxyacetic acid (4-ANA) challenges this paradigm.[1] It is a heterobifunctional, fluorescent linker that serves a dual purpose: it provides a rigid aromatic spacer to reduce steric hindrance while simultaneously acting as an intrinsic fluorescent reporter.

This Application Note details the physicochemical properties of 4-ANA and provides validated protocols for its use in solid-phase peptide synthesis (SPPS) and solution-phase bioconjugation.[1] By exploiting the solvatochromic properties of the naphthalene core, researchers can utilize 4-ANA to monitor conjugate integrity, track cellular uptake, and design "turn-on" cleavage assays without the need for bulky, extrinsic fluorophores.

Physicochemical Profile

4-ANA consists of a naphthalene core substituted at the 1-position with an oxyacetic acid moiety (hydrophilic, carboxyl-reactive) and at the 4-position with an amine (nucleophilic).[1]

This "push-pull" electronic structure confers unique optical properties.

Table 1: Optical & Physical Properties

Property	Value / Characteristic	Notes
Molecular Weight	~217.22 g/mol	Small footprint compared to FITC/Rhodamine.[2][1]
Excitation Max ()	300 – 340 nm	UV-excitable; compatible with DAPI filters.[1]
Emission Max ()	420 – 460 nm	Blue/Cyan emission.
Stokes Shift	~100 nm	Large shift reduces self-quenching artifacts.[1]
Solvatochromism	High	Emission red-shifts in polar solvents (e.g., water) and blue-shifts in hydrophobic pockets. [1]
Reactivity	Heterobifunctional	Contains 1 Aromatic Amine, 1 Carboxylic Acid.[2]

Mechanism of Action: The Solvatochromic Switch

Unlike standard alkyl linkers, 4-ANA's fluorescence is highly sensitive to its immediate environment.[1]

- Intact Conjugate (Quenched/Shifted): When buried in a hydrophobic protein pocket or conjugated to a quenching payload (e.g., Doxorubicin), 4-ANA fluorescence is often dimmed or blue-shifted.[2][1]

- Cleavage/Release (Bright/Red-Shifted): Upon linker cleavage (e.g., enzymatic hydrolysis), the 4-ANA moiety is released into the aqueous cytosol, resulting in a characteristic hyperchromic shift (increase in intensity) and bathochromic shift (red-shift).[2][1]

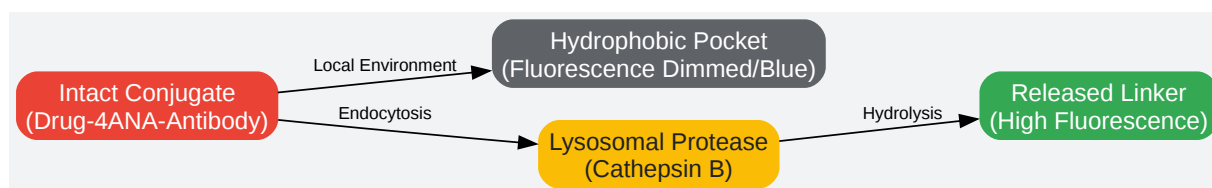

[Click to download full resolution via product page](#)

Figure 1: The "Turn-On" mechanism.[2][1] The 4-ANA linker acts as an environmental sensor, changing its emission profile upon release from the carrier or hydrophobic pocket.[1]

Experimental Protocols

Protocol A: Synthesis of Fmoc-4-ANA for SPPS

For researchers incorporating the linker into peptide sequences (e.g., for FRET probes).[2][1]

Reagents: 4-amino-1-naphthoxyacetic acid, Fmoc-Cl (9-Fluorenylmethyl chloroformate), NaHCO₃, Dioxane/Water.[2][1]

- Dissolution: Dissolve 1.0 eq of 4-amino-1-naphthoxyacetic acid in 1:1 Dioxane:10% NaHCO₃ (aq). Ensure pH is >8.
- Protection: Add 1.2 eq of Fmoc-Cl dropwise at 0°C.
- Reaction: Stir at room temperature for 4–6 hours. Monitor by TLC (disappearance of free amine).
- Workup: Acidify carefully with 1M HCl to pH 2 (precipitate forms). Extract with Ethyl Acetate.
- Purification: Recrystallize from Ethanol/Hexane.

- Critical Check: The aromatic amine is less nucleophilic than aliphatic amines. Ensure complete reaction before workup to avoid mixed species.

Protocol B: Solution-Phase Bioconjugation (Linker Insertion)

Strategy: Attach Linker to Payload (Drug) first, then to Antibody.[\[2\]](#)[\[1\]](#)

Phase 1: Amide Coupling to Payload (Drug-NH₂)

- Activation: Dissolve 4-ANA (1 eq) in dry DMF. Add EDC (1.2 eq) and NHS (1.2 eq). Stir for 30 min to form the NHS-ester.[\[1\]](#)
 - Note: Perform in dark/amber vials. Naphthalene derivatives are photo-stable but best practice dictates light protection during activation.[\[1\]](#)
- Coupling: Add the amine-containing payload (Drug-NH₂, 1 eq) and DIPEA (2 eq). Stir for 12 hours.
- Result: H₂N-Naphthyl-O-CH₂-CO-NH-Drug.
 - Purification: HPLC (C18 column).[\[3\]](#) Monitor absorbance at 320 nm (naphthalene) and drug specific wavelength.

Phase 2: Coupling to Antibody (Ab-COOH) Since the 4-ANA amine is aromatic (aniline-like), it is less reactive.[\[1\]](#) We recommend converting the Antibody carboxyls to reactive esters, or using a succinic anhydride spacer if the antibody has surface lysines.

Alternative High-Yield Route (Succinic Spacer):

- React the H₂N-Naphthyl-Drug construct with Succinic Anhydride to generate a free terminal carboxylic acid: HOOC-CH₂-CH₂-CO-NH-Naphthyl-Drug.[\[2\]](#)[\[1\]](#)
- Activate this new carboxyl with EDC/NHS.
- React with Antibody surface Lysines.

Workflow Visualization

The following diagram illustrates the bioconjugation logic, specifically addressing the reactivity difference between the aromatic amine and the aliphatic carboxyl.

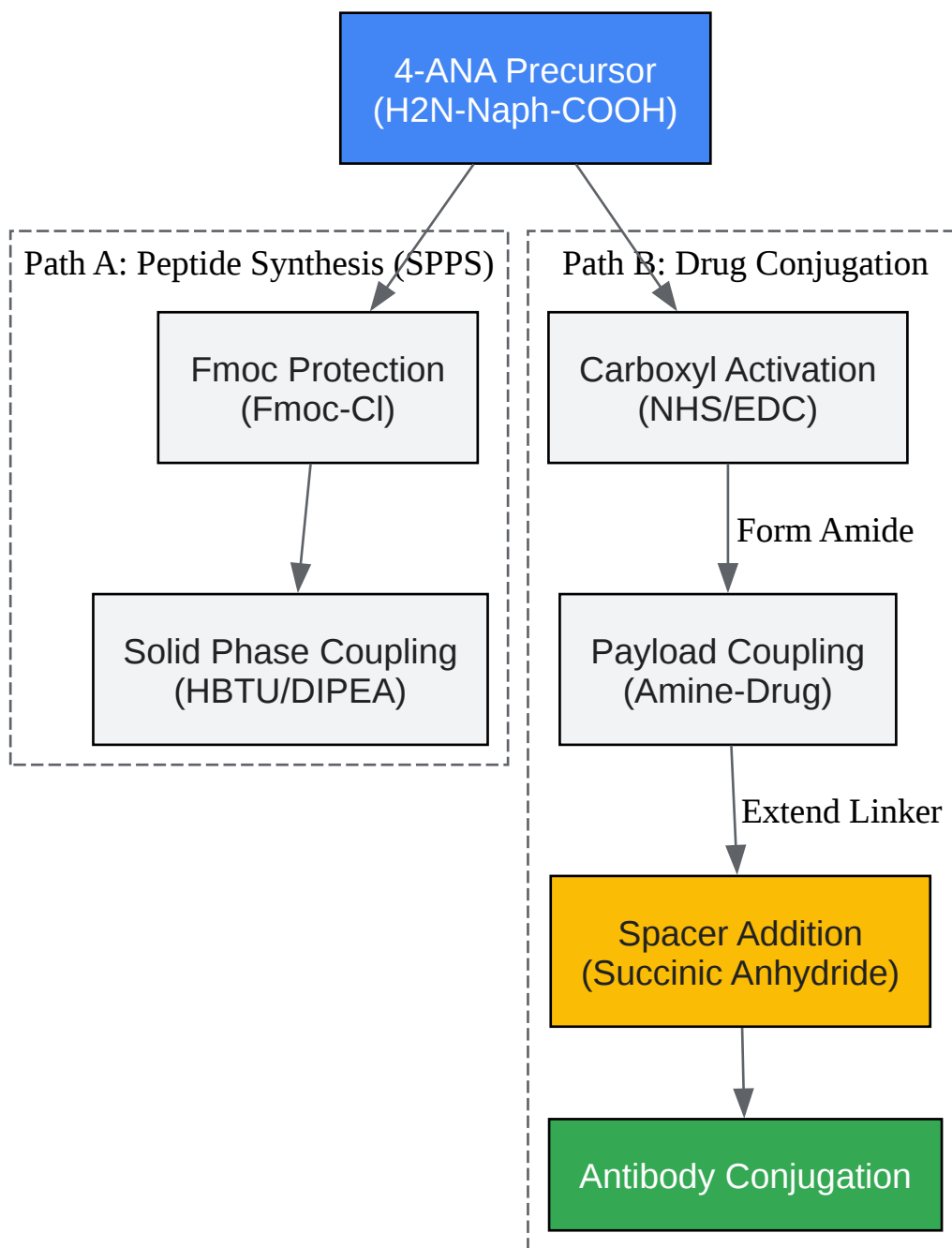

[Click to download full resolution via product page](#)

Figure 2: Strategic decision tree for 4-ANA conjugation. Path A is for peptide probes; Path B is for small molecule drug delivery systems.

Troubleshooting & Expert Tips

1. Fluorescence Quenching:

- Issue: Low signal after conjugation.

- Cause:

-

stacking interactions between the naphthalene ring and aromatic amino acids (Trp, Tyr) or DNA bases.[2]

- Solution: Add a short PEG spacer (PEG2) adjacent to the 4-ANA if the payload is highly hydrophobic.[1] This disrupts stacking.

2. Solubility:

- Issue: Precipitate forms during coupling.

- Cause: The naphthalene core is hydrophobic.[4]

- Solution: Ensure the reaction solvent is at least 30% organic (DMF/DMSO) when coupling to proteins. If the protein is sensitive, use a sulfonated analog of 4-ANA (though this changes the chemical structure) or add cyclodextrins during the reaction to solubilize the linker.

3. Aromatic Amine Reactivity:

- Issue: Poor yield when coupling the 4-amino group.

- Insight: The amine on the naphthalene ring is an aniline. Its pKa is lower (~4-5) compared to alkyl amines (~10).[1] It is less nucleophilic.

- Correction: Do not use standard NHS esters to couple to this amine. Instead, use highly reactive acyl chlorides or activate the incoming carboxyl with HATU/HOAt, which is more efficient for aniline coupling.

References

- Lakowicz, J. R. (2006). Principles of Fluorescence Spectroscopy. Springer.
- Wagner, R. et al. (2022). "Linker Molecules Convert Commercial Fluorophores into Tailored Functional Probes".^[5] National Institutes of Health (PMC). [Link](#)
- BenchChem Application Notes. (2025). "Minimizing fluorescence quenching of naphthalene-based derivatives". [Link](#)^[2]
- Liu, J. et al. (2021).^[2]^[3] "A 4-aminonaphthalimide-based fluorescent traceable prodrug".^[1] ^[3] Chemical Communications. (Demonstrates the utility of aminonaphthalene derivatives as traceable linkers). [Link](#)
- Bedair, A. H. et al. (2006).^[6] "Preparation of 4-aminophenylacetic acid derivatives". Acta Pharm.^[6]^[7] (Synthetic protocols for similar aromatic amino-acid linkers). [Link](#)

Need Custom Synthesis?

BenchChem offers custom synthesis for rare earth carbides and specific isotopic labeling.

Email: info@benchchem.com or [Request Quote Online](#).

Sources

- 1. US20030083525A1 - Preparation of 4-amino-1-naphthol ethers - Google Patents [patents.google.com]
- 2. Stereoselective Syntheses of Fluorescent Non-Natural Aromatic Amino Acids Based on Asymmetric Michael Additions - PMC [pubmed.ncbi.nlm.nih.gov]
- 3. researchgate.net [researchgate.net]
- 4. Naphthalene and its Derivatives: Efficient Fluorescence Probes for Detecting and Imaging Purposes - PubMed [pubmed.ncbi.nlm.nih.gov]
- 5. Linker Molecules Convert Commercial Fluorophores into Tailored Functional Probes during Biolabelling - PMC [pubmed.ncbi.nlm.nih.gov]
- 6. hrcak.srce.hr [hrcak.srce.hr]
- 7. researchgate.net [researchgate.net]

- To cite this document: BenchChem. [Using 4-aminonaphthoxyacetic acid as a fluorescent linker]. BenchChem, [2026]. [Online PDF]. Available at: [<https://www.benchchem.com/product/b13597245/docs#using-4-aminonaphthoxyacetic-acid-as-a-fluorescent-linker>]

Disclaimer & Data Validity:

The information provided in this document is for Research Use Only (RUO) and is strictly not intended for diagnostic or therapeutic procedures. While BenchChem strives to provide accurate protocols, we make no warranties, express or implied, regarding the fitness of this product for every specific experimental setup.

Technical Support: The protocols provided are for reference purposes. Unsure if this reagent suits your experiment?

Need Industrial/Bulk Grade? [Request Custom Synthesis Quote](#)

BenchChem

Our mission is to be the trusted global source of essential and advanced chemicals, empowering scientists and researchers to drive progress in science and industry.

Contact

Address: 3281 E Guasti Rd
Ontario, CA 91761, United States
Phone: (601) 213-4426
Email: info@benchchem.com

[Contact our Ph.D. Support Team for a compatibility check](#)