

Technical Support Center: Scaling Up 1-Methoxy-3-nitropropane Synthesis

Author: BenchChem Technical Support Team. **Date:** May 2026

Compound of Interest

Compound Name: 1-Methoxy-3-nitropropane

Cat. No.: B13594046

[Get Quote](#)

Target Molecule: **1-Methoxy-3-nitropropane** CAS: 13047-13-7 Formula:

Classification: Aliphatic Nitro Compound / Ether

Executive Summary & Route Selection

User Query: "I need to scale this reaction from gram-scale to kilogram-scale. Which synthetic route balances cost, safety, and purity?"

The Core Challenge: Ambident Nucleophilicity

The synthesis of **1-Methoxy-3-nitropropane** primarily relies on the nucleophilic substitution of 1-bromo-3-methoxypropane with a nitrite ion (

).

The critical difficulty in scaling this reaction is the ambident nature of the nitrite ion, which possesses two nucleophilic centers:

- Nitrogen (N-attack): Forms the desired Nitroalkane ().
- Oxygen (O-attack): Forms the unstable Alkyl Nitrite Ester (

).

Strategic Route Comparison

For scale-up, we recommend Route B (Modified Kornblum) over Route A due to the prohibitive cost of silver salts and waste disposal issues, despite Route A's higher initial selectivity.

Feature	Route A: Victor Meyer (Silver Nitrite)	Route B: Modified Kornblum (Sodium Nitrite)
Reagents	(Silver Nitrite)	(Sodium Nitrite)
Mechanism	(Assisted by Ag precipitation)	(Solvent dependent)
Selectivity	High (~80% Nitro / 20% Nitrite)	Low (~60% Nitro) without modification
Cost	Extremely High (Prohibitive at kg scale)	Low (Commodity chemical)
Scale-up Risk	Heavy metal waste management	Thermal runaway; Nitrite ester byproduct
Recommendation	Bench Scale Only (<50g)	Production Scale (>1kg)

Detailed Protocol: Modified Kornblum Reaction (Scale-Up Optimized)

Objective: Synthesis of 1 kg of **1-Methoxy-3-nitropropane** using the Sodium Nitrite/DMSO route with urea scavenging.

Reagents & Materials[1][2][3][4][5][6][7][8]

- Substrate: 1-Bromo-3-methoxypropane (1.0 equiv)
- Reagent: Sodium Nitrite (), dry powder (1.5 - 2.0 equiv)

- Solvent: Dimethyl Sulfoxide (DMSO) or Dimethylformamide (DMF).[1] Note: DMSO is safer regarding chronic toxicity but requires careful thermal management.
- Scavenger: Urea (0.5 equiv) - Critical for preventing side reactions caused by nitrous acid.

Step-by-Step Methodology

- Reactor Preparation:
 - Use a glass-lined reactor or Hastelloy (avoid iron/steel due to corrosion from potential).
 - Ensure efficient overhead stirring (anchor impeller recommended for slurry suspension).
 - Safety Check: Verify cooling jacket functionality. This reaction is exothermic.[2]
- Solvent & Reagent Charging:
 - Charge DMSO (5-7 volumes relative to substrate).
 - Add Sodium Nitrite () and Urea.
 - Note:

has low solubility in DMSO; this will be a slurry. High agitation is required.
- Temperature Control (Critical):
 - Cool the slurry to 15–20°C.
 - Do not heat the slurry before addition.
- Controlled Addition:
 - Add 1-Bromo-3-methoxypropane dropwise via a dosing pump.
 - Rate Limit: Maintain internal temperature <30°C.

- Warning: Rapid addition will trigger a delayed exotherm.
- Reaction Phase:
 - Once addition is complete, allow the mixture to warm to room temperature (25°C).
 - Stir for 6–12 hours. Monitor conversion via GC-FID.
 - Endpoint: Disappearance of bromide.
- Work-Up (Emulsion Breaking):
 - Pour the reaction mixture into 5x volume of ice water. (The high water ratio is necessary to extract DMSO).
 - Extract with Diethyl Ether or MTBE (Methyl tert-butyl ether).
 - Wash organic layer with saturated solution (removes residual DMSO).
 - Dry over and concentrate.
- Purification:
 - Distillation: The byproduct (1-methoxy-3-propyl nitrite) boils lower than the nitro compound.
 - Perform fractional distillation under reduced pressure.

Process Visualization

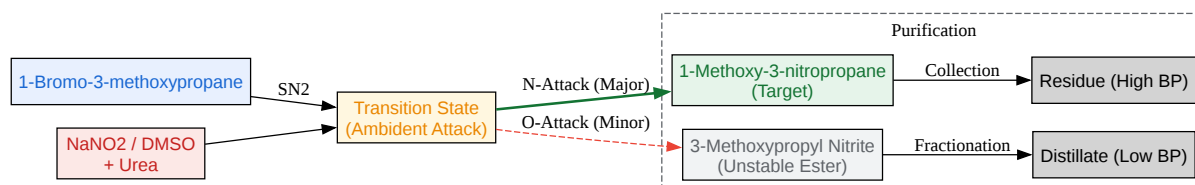

[Click to download full resolution via product page](#)

Caption: Reaction pathway illustrating the competitive N-attack vs. O-attack mechanism and purification logic.

Troubleshooting Guide (FAQs)

Q1: I am seeing a "Red Oil" forming in the reactor. What is this?

Diagnosis: This is likely a complex mixture of alkyl nitrites and oxidation byproducts caused by Nitrous Acid (

). The Fix:

- Ensure Urea or Phloroglucinol was added to the reaction. These scavenge nitrite esters and nitrous acid.
- Immediate Action: If red oil is observed, check pH. If acidic, neutralize carefully with solid

Q2: My yield is stuck at 50-60%. How do I improve this?

Diagnosis: You are likely favoring O-alkylation (Nitrite ester formation). The Fix:

- Temperature: Lower the addition temperature. Higher temperatures favor O-attack (hard/hard interaction). Keep addition <20°C.

- Solvent: Ensure the DMSO/DMF is anhydrous. Water creates a hydration shell around the nitrite ion, altering its nucleophilicity.

Q3: I cannot remove DMSO from the final product.

Diagnosis: DMSO has a high boiling point (189°C) and tracks with polar products. The Fix:

- The "5x Rule": During workup, the aqueous volume must be at least 5 times the DMSO volume.
- LiCl Wash: Wash the organic extract with 5% Lithium Chloride solution.^[3] DMSO partitions strongly into aqueous LiCl.

Q4: Is it safe to distill the product?

Diagnosis: Nitro compounds are thermally sensitive. The Fix:

- Never distill to dryness.
- Vacuum is mandatory: Distill at <5 mmHg to keep the pot temperature below 100°C.
- DSC Check: Perform Differential Scanning Calorimetry (DSC) on the crude mixture before heating large batches to determine the onset of decomposition.

Safety & Waste Management

Hazard Identification

Hazard	Description	Mitigation
Explosion	Nitroalkanes can decompose violently at high temps.	Keep process temp <100°C. Use rupture disks on reactors.
Toxicity	1-Methoxy-3-nitropropane is a potential alkylating agent.	Use full PPE. ^{[4][5]} Handle in a fume hood/glovebox.
DMSO/NaNO ₂	Mixtures of DMSO and oxidizers/halides can be explosive.	Never mix DMSO and NaNO ₂ with strong acids or acyl halides.

Process Flow Diagram

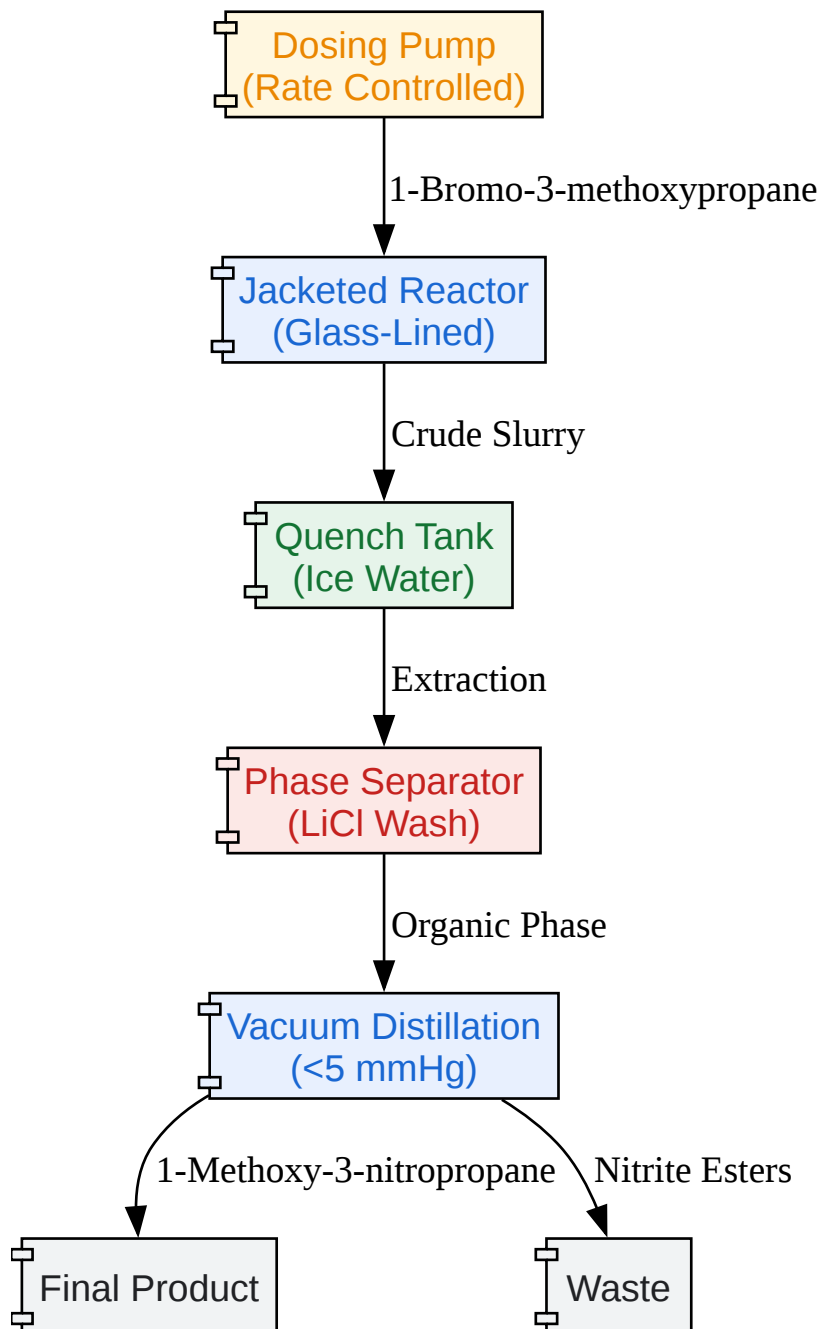

[Click to download full resolution via product page](#)

Caption: Scale-up process flow emphasizing controlled dosing and downstream separation.

References

- Kornblum, N., et al. (1956). "The Reaction of Alkyl Halides with Sodium Nitrite." *Journal of the American Chemical Society*. 78(7), 1497–1501.
- Ballini, R., et al. (2004).[6] "The First Conversion of Primary Alkyl Halides to Nitroalkanes under Aqueous Medium." *Journal of Organic Chemistry*. 69(20), 6907-6908.
- PubChem. (n.d.). "1-Bromo-3-methoxypropane Compound Summary." National Library of Medicine.
- University of Rochester. (n.d.). "Workup for Reactions in DMF or DMSO." Not Voodoo X.
- Purdue University. (n.d.). "Potential Explosion Hazards with Using DMSO and DMF in Chemical Reactions." Purdue Safety Updates.

Need Custom Synthesis?

BenchChem offers custom synthesis for rare earth carbides and specific isotopic labeling.

Email: info@benchchem.com or [Request Quote Online](#).

Sources

- [1. lkouniv.ac.in](http://lkouniv.ac.in) [lkouniv.ac.in]
- [2. From Flask to Floor: Overcoming Scale-Up Challenges in Pharmaceutical Synthesis - HWS Labortechnik Mainz](#) [hws-mainz.de]
- [3. Workup](#) [chem.rochester.edu]
- [4. fishersci.com](#) [fishersci.com]
- [5. cameochemicals.noaa.gov](#) [cameochemicals.noaa.gov]
- [6. The First Conversion of Primary Alkyl Halides to Nitroalkanes under Aqueous Medium](#) [organic-chemistry.org]
- To cite this document: BenchChem. [Technical Support Center: Scaling Up 1-Methoxy-3-nitropropane Synthesis]. BenchChem, [2026]. [Online PDF]. Available at: [<https://www.benchchem.com/product/b13594046/docs#technical-support-center-scaling-up-1-methoxy-3-nitropropane-synthesis>]

Disclaimer & Data Validity:

The information provided in this document is for Research Use Only (RUO) and is strictly not intended for diagnostic or therapeutic procedures. While BenchChem strives to provide accurate protocols, we make no warranties, express or implied, regarding the fitness of this product for every specific experimental setup.

Technical Support: The protocols provided are for reference purposes. Unsure if this reagent suits your experiment?

Need Industrial/Bulk Grade? [Request Custom Synthesis Quote](#)

BenchChem

Our mission is to be the trusted global source of essential and advanced chemicals, empowering scientists and researchers to drive progress in science and industry.

Contact

Address: 3281 E Guasti Rd
Ontario, CA 91761, United States
Phone: (601) 213-4426
Email: info@benchchem.com

[Contact our Ph.D. Support Team for a compatibility check](#)