

# Technical Comparison Guide: Mass Spectrometry Fragmentation of Chlorinated Benzothiophenes

**Author:** BenchChem Technical Support Team. **Date:** May 2026

## Compound of Interest

**Compound Name:** *3-Chloro-1-benzothiophen-6-aminehydrochloride*

**Cat. No.:** *B13591882*

[Get Quote](#)

## Executive Summary

Chlorinated benzothiophenes (PCBTs) represent a niche but critical class of compounds found as environmental pollutants (effluents from pulp bleaching, incineration by-products) and as impurities in pharmaceutical synthesis (e.g., thiophene-based drugs). Their analysis is complicated by two factors: the existence of multiple positional isomers and significant isobaric interference from polychlorinated naphthalenes (PCNs) and polychlorinated biphenyls (PCBs).

[1]

This guide compares the efficacy of Electron Ionization (EI), Negative Chemical Ionization (NCI), and High-Resolution Mass Spectrometry (HRMS) for the characterization of PCBTs. It provides a validated fragmentation model to assist in structural elucidation.

## Part 1: Fragmentation Mechanics & Structural Logic

Understanding the fragmentation of PCBTs requires dissecting the stability of the benzothiophene core against the lability of the C-Cl bond. Unlike PCBs, where the biphenyl

core is robust, the thiophene ring in PCBTs introduces specific fragmentation pathways involving sulfur loss.

## The Fragmentation Pathway

In Electron Ionization (70 eV), PCBTs exhibit a "stripping" mechanism. The molecular ion ( ) is typically the base peak or very intense. The fragmentation follows a sequential loss of radical chlorine atoms and the extrusion of the sulfur moiety.

Key Diagnostic Ions:

- : Loss of a chlorine radical.
- : Characteristic disintegration of the thiophene ring (Loss of 44 Da).
- $[M-Cl_2]^+ / [M-HCl]^+$ : Sequential dechlorination.

## Visualization of Fragmentation (DOT Diagram)

The following diagram illustrates the primary fragmentation pathway for a generic trichlorobenzothiophene (

), highlighting the divergence between simple dechlorination and ring opening.

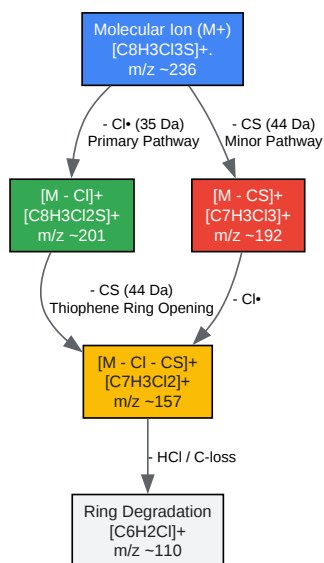

Figure 1: EI Fragmentation Pathway of Trichlorobenzothiophene showing characteristic loss of Chlorine and Carbon Monosulfide.

[Click to download full resolution via product page](#)

## Part 2: Comparative Analysis of MS Techniques

Selecting the right ionization mode is the single most important decision in PCBT analysis. The choice depends on whether the goal is structural identification (Isomer differentiation) or trace quantification (Environmental monitoring).

### Table 1: Performance Matrix of MS Techniques

Feature	GC-EI-MS (Low Res)	GC-NCI-MS	GC-HRMS (Orbitrap/Q-TOF)
Primary Mechanism	Hard ionization (70 eV). Generates fragments for structural ID.	Soft ionization (Electron Capture). Generates or .	Hard or Soft. Measures exact mass (<2 ppm accuracy).
Sensitivity	Moderate (pg range).	Extreme (fg range) for highly chlorinated congeners.	High (depends on mode).
Selectivity	Low. PCBTs overlap with PCNs.	High for Cl-compounds, but blind to non-electrophiles.	Ultimate. Resolves Mass Defect of Sulfur.
Isomer ID	Possible via library matching of fragment ratios.	Poor. Often produces only molecular ions.	Excellent. Can resolve isobaric interferences.
Best Use Case	General screening & library matching.[2]	Environmental trace analysis (water/soil). [1][3][4]	Confirmation of unknowns & impurity profiling.

## Critical Insight: The Isobaric Trap

Researchers often confuse PCBTs with Polychlorinated Naphthalenes (PCNs).

- PCNs ( ): Mass differs from PCBTs ( ) by only ~2-3 Da in nominal mass, but exact mass differs significantly due to the Mass Defect of Sulfur.
- Solution: If using Low-Res MS, you must check the isotope ratio.[5] PCBTs have a distinct pattern due to the combined presence of Cl and S (

vs

is 4.2% abundance).

## Part 3: Validated Experimental Protocol

This protocol is designed for the separation of PCBT isomers using a standard single-quadrupole GC-MS, optimized to minimize sulfur-tailing.

### Sample Preparation (Self-Validating Step)

- Extraction: Liquid-Liquid Extraction (LLE) with Hexane (for water) or Soxhlet (for solids).
- Cleanup: Silica gel column fractionation is mandatory to remove polar interferences that suppress ionization.
- Internal Standard: Use

-labeled PCB 101 or Fluorinated Benzothiophene. Why? Deuterated standards may experience H/D exchange in active injector ports.

### GC-MS Instrument Conditions

Parameter	Setting	Rationale
Column	DB-5ms or Rtx-5Sil MS (30m x 0.25mm x 0.25µm)	Low-bleed phase essential for S-compounds.
Carrier Gas	Helium @ 1.2 mL/min (Constant Flow)	Maintains resolution of late-eluting isomers.
Injector	Splitless @ 280°C	High temp ensures volatilization of planar aromatics.
Transfer Line	290°C	Prevents cold-spot condensation of hexachlorobenzothiophenes.
Ion Source	230°C (EI) / 150°C (NCI)	NCI Note: Lower source temp enhances electron capture resonance.

## Acquisition Method

- Solvent Delay: 3.5 min (protect filament).
- Scan Range: m/z 100 – 500.
- SIM Mode (Quantitation):
  - Target the Molecular Ion Cluster (
    - ,
    - ,
    - ).
  - Target the
    - fragment for confirmation.

## Data Validation Workflow (DOT Diagram)

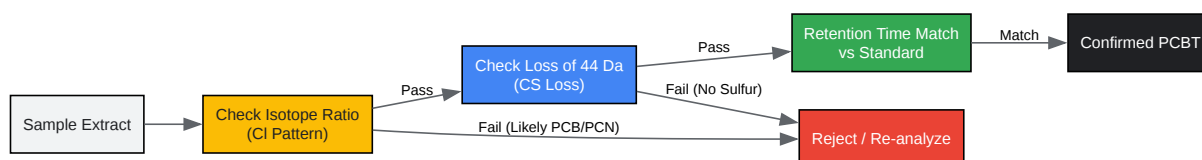

[Click to download full resolution via product page](#)

Figure 2: Decision tree for validating PCBT identification in complex matrices.

## References

- NIST Mass Spectrometry Data Center. (2023). Mass Spectrum of Benzo[b]thiophene derivatives. National Institute of Standards and Technology. [\[Link\]](#)
- Pedersen-Bjergaard, S., et al. (1993).[6] Identification of chlorinated sulfur compounds in pulp mill effluents by GC-MS and GC-AED. Chromatographia. [\[Link\]](#)
- Wei, H., & Li, A. (20XX).[7] Mass Spectrometric Ionization Pattern of Polychlorinated Biphenyls (Comparison to related aromatics). Dioxin 20XX International Symposium. [\[Link\]](#)
- Andersson, P., et al. (1996). Polychlorinated naphthalenes (PCNs) in sediment and biota. Environmental Science & Technology. (Contextual reference for isobaric interference).

### Need Custom Synthesis?

BenchChem offers custom synthesis for rare earth carbides and specific isotopic labeling.

Email: [info@benchchem.com](mailto:info@benchchem.com) or [Request Quote Online](#).

## Sources

- 1. [documents.thermofisher.com](https://documents.thermofisher.com) [[documents.thermofisher.com](https://documents.thermofisher.com)]
- 2. [uoguelph.ca](https://uoguelph.ca) [[uoguelph.ca](https://uoguelph.ca)]
- 3. [agilent.com](https://agilent.com) [[agilent.com](https://agilent.com)]

- [4. researchgate.net \[researchgate.net\]](https://www.researchgate.net)
- [5. chemguide.co.uk \[chemguide.co.uk\]](https://www.chemguide.co.uk)
- [6. researchprofiles.ku.dk \[researchprofiles.ku.dk\]](https://www.researchprofiles.ku.dk)
- [7. dioxin20xx.org \[dioxin20xx.org\]](https://www.dioxin20xx.org)
- To cite this document: BenchChem. [Technical Comparison Guide: Mass Spectrometry Fragmentation of Chlorinated Benzothiophenes]. BenchChem, [2026]. [Online PDF]. Available at: [<https://www.benchchem.com/product/b13591882/docs#technical-comparison-guide-mass-spectrometry-fragmentation-of-chlorinated-benzothiophenes>]

---

### Disclaimer & Data Validity:

The information provided in this document is for Research Use Only (RUO) and is strictly not intended for diagnostic or therapeutic procedures. While BenchChem strives to provide accurate protocols, we make no warranties, express or implied, regarding the fitness of this product for every specific experimental setup.

**Technical Support:** The protocols provided are for reference purposes. Unsure if this reagent suits your experiment?

**Need Industrial/Bulk Grade?** [Request Custom Synthesis Quote](#)

## BenchChem

Our mission is to be the trusted global source of essential and advanced chemicals, empowering scientists and researchers to drive progress in science and industry.

### Contact

Address: 3281 E Guasti Rd  
Ontario, CA 91761, United States  
Phone: (601) 213-4426  
Email: [info@benchchem.com](mailto:info@benchchem.com)

[Contact our Ph.D. Support Team for a compatibility check](#)

