

# Introduction: The Strategic Advantage of Bifunctional Reagents

**Author:** BenchChem Technical Support Team. **Date:** April 2026

## Compound of Interest

Compound Name: 4-(Aminomethyl)oxolan-2-one hydrochloride

Cat. No.: B13583105

[Get Quote](#)

Bioconjugation, the chemical linking of two molecules where at least one is a biomolecule, is a cornerstone of modern biotechnology, enabling the creation of advanced therapeutics like antibody-drug conjugates (ADCs), sophisticated diagnostic tools, and novel research reagents. [1][2][3] The choice of linker is critical, as it influences the stability, functionality, and overall performance of the resulting bioconjugate.[4]

4-(Aminomethyl)oxolan-2-one hydrochloride presents a unique chemical architecture, featuring a primary amine and a gamma-butyrolactone (a cyclic ester). This dual functionality allows for two distinct strategies for covalent bond formation, offering flexibility in the design of bioconjugation workflows. This guide will detail these two approaches: leveraging the nucleophilic primary amine for reaction with electrophiles, and exploiting the lactone ring for modification via nucleophilic attack from biomolecules.

## PART 1: Bioconjugation via the Primary Amine Moiety

The primary aminomethyl group is a versatile handle for bioconjugation. In its hydrochloride salt form, the amine is protonated ( $\text{—NH}_3^+$ ). To render it nucleophilic ( $\text{—NH}_2$ ) for conjugation, it is

essential to perform the reaction in a buffer system with a pH above the amine's pKa, typically in the range of 7.5 to 9.0.

## Mechanism of Amine-Reactive Conjugation

The most common strategy for targeting primary amines on a linker is through the use of N-hydroxysuccinimide (NHS) esters. NHS esters react with primary amines to form stable amide bonds, releasing the NHS leaving group. This is a highly efficient and widely adopted method for protein labeling and modification.[5][6]

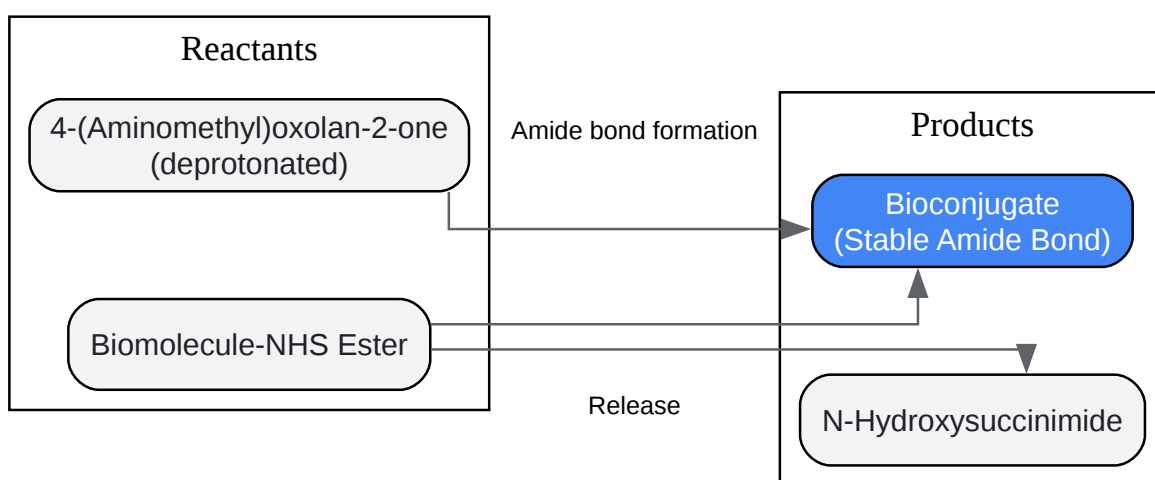

[Click to download full resolution via product page](#)

Caption: Amine-reactive conjugation workflow.

## Protocol 1: Modification of an NHS-Ester Activated Biomolecule

This protocol describes a general procedure for conjugating 4-(Aminomethyl)oxolan-2-one to a biomolecule (e.g., a protein, antibody, or surface) that has been pre-activated with NHS esters.

Materials:

- 4-(Aminomethyl)oxolan-2-one hydrochloride
- NHS-ester activated biomolecule

- Reaction Buffer: 100 mM sodium phosphate, 150 mM NaCl, pH 8.0
- Quenching Buffer: 1 M Tris-HCl, pH 8.0
- Purification system (e.g., size-exclusion chromatography, dialysis)

#### Procedure:

- Reagent Preparation: Prepare a 10 mM stock solution of 4-(Aminomethyl)oxolan-2-one hydrochloride in the Reaction Buffer. The buffer will neutralize the hydrochloride and deprotonate the amine.
- Biomolecule Preparation: Dissolve the NHS-ester activated biomolecule in the Reaction Buffer to a final concentration of 1-10 mg/mL.
- Conjugation Reaction: Add a 10- to 50-fold molar excess of the 4-(Aminomethyl)oxolan-2-one solution to the activated biomolecule solution. The optimal ratio should be determined empirically.
- Incubation: Incubate the reaction mixture for 1-2 hours at room temperature or overnight at 4°C with gentle stirring.
- Quenching: Add Quenching Buffer to a final concentration of 50 mM to quench any unreacted NHS esters. Incubate for 30 minutes at room temperature.
- Purification: Remove excess, unreacted 4-(Aminomethyl)oxolan-2-one and byproducts by size-exclusion chromatography or dialysis against a suitable buffer (e.g., PBS, pH 7.4).
- Characterization: Analyze the resulting conjugate to confirm modification. Recommended techniques include MALDI-TOF mass spectrometry to determine the mass shift, and SDS-PAGE to observe changes in molecular weight.

Parameter	Recommended Condition	Rationale
pH	7.5 - 9.0	Ensures the primary amine is deprotonated and nucleophilic.
Molar Ratio	10:1 to 50:1 (Reagent:Biomolecule)	Drives the reaction to completion.
Temperature	4°C to 25°C	Lower temperatures can minimize protein degradation.
Reaction Time	1 - 4 hours	Sufficient for most NHS-ester reactions.

## PART 2: Bioconjugation via Lactone Ring-Opening

A more novel approach involves using the lactone ring of 4-(Aminomethyl)oxolan-2-one as the electrophilic site for conjugation. This strategy relies on nucleophilic attack from amino acid side chains on a protein, primarily the  $\epsilon$ -amino group of lysine, to open the lactone ring and form a stable amide bond.

### Mechanism of Lactone Aminolysis

Under appropriate pH conditions (typically pH > 8.5), the lysine side-chain amine is sufficiently deprotonated to act as a nucleophile. It can attack the carbonyl carbon of the lactone, leading to ring-opening and the formation of a covalent amide linkage. This reaction creates a new 4-hydroxybutanamide linkage, effectively tethering the  $-(\text{CH}_2)_4\text{-NH}_2$  moiety to the protein.

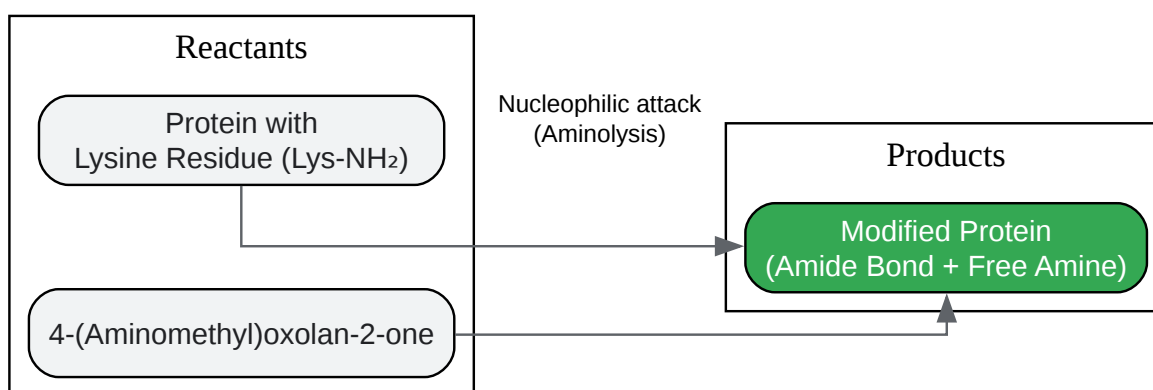

[Click to download full resolution via product page](#)

Caption: Lactone ring-opening by a protein's lysine residue.

## Protocol 2: Protein Modification via Lactone Aminolysis

This protocol outlines a potential method for modifying a protein using the lactone functionality. Note that this reaction may be less efficient than canonical bioconjugation methods and requires careful optimization.

Materials:

- 4-(Aminomethyl)oxolan-2-one hydrochloride
- Target protein with accessible lysine residues (e.g., an antibody)
- High-pH Reaction Buffer: 100 mM sodium borate, pH 9.0
- Purification system (e.g., size-exclusion chromatography, dialysis)

Procedure:

- Reagent Preparation: Prepare a 100 mM stock solution of 4-(Aminomethyl)oxolan-2-one hydrochloride in the High-pH Reaction Buffer.
- Protein Preparation: Exchange the protein into the High-pH Reaction Buffer to a final concentration of 5-20 mg/mL. Be mindful of the protein's stability at this pH.
- Conjugation Reaction: Add a 100- to 1000-fold molar excess of the 4-(Aminomethyl)oxolan-2-one solution to the protein solution. A higher excess is likely needed due to the lower reactivity of the lactone compared to NHS esters and potential for hydrolysis.
- Incubation: Incubate the reaction for 4-24 hours at a controlled temperature (e.g., 37°C) to facilitate the reaction. Monitor the protein for signs of aggregation or degradation.
- Purification: Immediately after incubation, purify the protein conjugate using size-exclusion chromatography or extensive dialysis against a storage buffer (e.g., PBS, pH 7.4) to remove excess reagent and stop the reaction.

- **Characterization:** Confirm conjugation using mass spectrometry to detect the addition of the reagent's mass (minus water). The newly introduced primary amines can be quantified using amine-reactive assays.

Parameter	Recommended Condition	Rationale
pH	8.5 - 9.5	Increases the nucleophilicity of lysine $\epsilon$ -amino groups.
Molar Ratio	100:1 to 1000:1 (Reagent:Protein)	High excess needed to overcome lower reactivity and hydrolysis.
Temperature	25°C to 37°C	Higher temperature can increase reaction rate.
Reaction Time	4 - 24 hours	Longer incubation may be necessary.

**Expert Insight & Trustworthiness:** The aminolysis of lactones is a valid chemical transformation, but its application in bioconjugation is not as widespread as other methods. The primary competing reaction is the hydrolysis of the lactone ring by water, which is significant at elevated pH. Therefore, a high concentration of the reagent is recommended to favor the bimolecular reaction with the protein over the unimolecular hydrolysis. Researchers should perform pilot experiments to optimize reaction time, temperature, and reagent concentration to maximize conjugation efficiency while preserving the integrity and function of the target biomolecule.

## Applications and Future Directions

The dual reactivity of 4-(Aminomethyl)oxolan-2-one hydrochloride opens several strategic possibilities:

- **Introduction of a Reactive Handle:** Modifying a protein via its lactone ring (Protocol 2) results in the introduction of a new, distal primary amine. This newly installed amine can then be used for subsequent, specific conjugation with an amine-reactive payload (e.g., a fluorescent dye, a drug molecule, or a biotin tag), offering a two-step, site-selective modification strategy.

- **Linker for Antibody-Drug Conjugates (ADCs):** The molecule can serve as a simple, hydrophilic linker in the construction of ADCs.<sup>[2][4][7]</sup> For instance, a cytotoxic drug with a carboxylic acid could be coupled to the amine of 4-(Aminomethyl)oxolan-2-one, and the resulting construct could then be conjugated to an antibody via the lactone ring-opening mechanism.
- **Surface Modification:** The amine functionality can be used to immobilize the molecule onto surfaces activated with NHS esters or similar electrophiles, presenting a lactone-functionalized surface for subsequent biomolecule capture.

## Conclusion

4-(Aminomethyl)oxolan-2-one hydrochloride is a promising, albeit under-explored, reagent for bioconjugation. Its simple structure and dual-mode reactivity provide a flexible platform for both established and novel conjugation strategies. While amine-reactive coupling represents a straightforward application, the potential for lactone-based modification offers an intriguing method for introducing new functionalities onto biomolecules. Successful implementation will rely on a solid understanding of the chemical principles outlined in this guide and a commitment to empirical optimization of reaction conditions to ensure the integrity and functionality of the final bioconjugate.

## References

- ResearchGate. "Drug-to-antibody ratio for complete conjugation." Available at: [\[Link\]](#)
- Today's Clinical Lab. "What is Bioconjugation? Overview, Applications & More." Available at: [\[Link\]](#)
- Springer Link. "Bioconjugation Protocols." Available at: [\[Link\]](#)
- PubMed. "Selective cleavage of thioether linkage in proteins modified with 4-hydroxynonenal." Available at: [\[Link\]](#)
- PMC. "An efficient system for bioconjugation based on a widely applicable engineered O-glycosylation tag." Available at: [\[Link\]](#)
- Single Use Support. "Bioconjugates: Examples & Applications." Available at: [\[Link\]](#)

- ResearchGate. "Bioconjugation Protocols: Strategies and Methods." Available at: [\[Link\]](#)
- ScienceDirect. "Recent developments in bioconjugation: From strategies to design and clinical applications." Available at: [\[Link\]](#)
- FUJIFILM Wako. "Antibody-drug Conjugate/ADC Related Catalog." Available at: [\[Link\]](#)
- Adooq Bioscience. "Antibody-drug Conjugates | ADC." Available at: [\[Link\]](#)
- PMC. "Preparation and characterization of antibody-drug conjugates acting on HER2-positive cancer cells." Available at: [\[Link\]](#)

### Need Custom Synthesis?

BenchChem offers custom synthesis for rare earth carbides and specific isotopic labeling.

Email: [info@benchchem.com](mailto:info@benchchem.com) or [Request Quote Online](#).

## Sources

- 1. [clinicallab.com](http://clinicallab.com) [[clinicallab.com](http://clinicallab.com)]
- 2. [susupport.com](http://susupport.com) [[susupport.com](http://susupport.com)]
- 3. [researchgate.net](http://researchgate.net) [[researchgate.net](http://researchgate.net)]
- 4. [labchem-wako.fujifilm.com](http://labchem-wako.fujifilm.com) [[labchem-wako.fujifilm.com](http://labchem-wako.fujifilm.com)]
- 5. Preparation and characterization of antibody-drug conjugates acting on HER2-positive cancer cells - PMC [[pmc.ncbi.nlm.nih.gov](http://pmc.ncbi.nlm.nih.gov)]
- 6. [lumiprobe.com](http://lumiprobe.com) [[lumiprobe.com](http://lumiprobe.com)]
- 7. Bioconjugation application notes [[bionordika.fi](http://bionordika.fi)]
- To cite this document: BenchChem. [Introduction: The Strategic Advantage of Bifunctional Reagents]. BenchChem, [2026]. [Online PDF]. Available at: [\[https://www.benchchem.com/product/b13583105/docs#introduction-the-strategic-advantage-of-bifunctional-reagents\]](https://www.benchchem.com/product/b13583105/docs#introduction-the-strategic-advantage-of-bifunctional-reagents)

---

### Disclaimer & Data Validity:

The information provided in this document is for Research Use Only (RUO) and is strictly not intended for diagnostic or therapeutic procedures. While BenchChem strives to provide accurate protocols, we make no warranties, express or implied, regarding the fitness of this product for every specific experimental setup.

**Technical Support:** The protocols provided are for reference purposes. Unsure if this reagent suits your experiment?

**Need Industrial/Bulk Grade?** [Request Custom Synthesis Quote](#)

## BenchChem

Our mission is to be the trusted global source of essential and advanced chemicals, empowering scientists and researchers to drive progress in science and industry.

### Contact

Address: 3281 E Guasti Rd  
Ontario, CA 91761, United States  
Phone: (601) 213-4426  
Email: [info@benchchem.com](mailto:info@benchchem.com)

[Contact our Ph.D. Support Team for a compatibility check](#)