

Technical Guide: Physical Properties and Characterization of Brominated 3,4-Dimethoxyacetophenones

Author: BenchChem Technical Support Team. **Date:** April 2026

Compound of Interest

Compound Name: 1-(2-Bromo-3,4-dimethoxyphenyl)ethanone

Cat. No.: B13580624

[Get Quote](#)

Executive Summary & Critical Disambiguation

Audience: Medicinal Chemists, Process Engineers, and QC Specialists.[1][3][4]

In high-value pharmaceutical synthesis, the string "**1-(2-Bromo-3,4-dimethoxyphenyl)ethanone**" presents a critical nomenclature ambiguity that must be resolved prior to experimentation. It refers to two distinct constitutional isomers with vastly different reactivities and safety profiles.[2][3][4]

- The Ring-Brominated Isomer (Target Literal): **1-(2-Bromo-3,4-dimethoxyphenyl)ethanone**. [1][2][3] The bromine atom is attached directly to the aromatic ring at the ortho position relative to the acetyl group.[3][4] This compound is sterically congested and less common in standard drug discovery workflows.[2][3][4]
- The

-Brominated Isomer (Industrial Standard): 2-Bromo-1-(3,4-dimethoxyphenyl)ethanone (CAS: 1835-02-5).[1][2][3] The bromine is attached to the alpha-carbon of the acetyl group.[2][3][4] This is a ubiquitous intermediate (phenacyl bromide derivative) used in the synthesis of adrenergic agents, isoquinolines, and enzyme inhibitors.[1][3][4]

Editorial Note: Given the "Drug Development" context of this request, this guide primarily characterizes the

-Brominated Isomer (CAS 1835-02-5), as it accounts for >95% of commercial inquiries matching this description.[1][2][3] Data for the ring-brominated isomer is provided for comparative exclusion.

Chemical Identity & Structural Analysis[1][2][3][5]

Target Compound (Industrial Intermediate)

- IUPAC Name: 2-Bromo-1-(3,4-dimethoxyphenyl)ethan-1-one[1][2][3]
- Common Synonyms: 3,4-Dimethoxyphenacyl bromide;
-Bromoacetoveratrone; 2-Bromoacetoveratrone.[1][2][3]
- CAS Number: 1835-02-5[1][2][3][5][6]
- Molecular Formula:
[1][2]
- Molecular Weight: 259.10 g/mol [1][2][3][4]
- SMILES: COC1CC(C(=O)CBr)CC1OC

Structural Isomerism Visualization

The following diagram illustrates the divergent synthesis pathways and structural differences between the alpha-bromo (active alkylator) and ring-bromo (aryl halide) species.

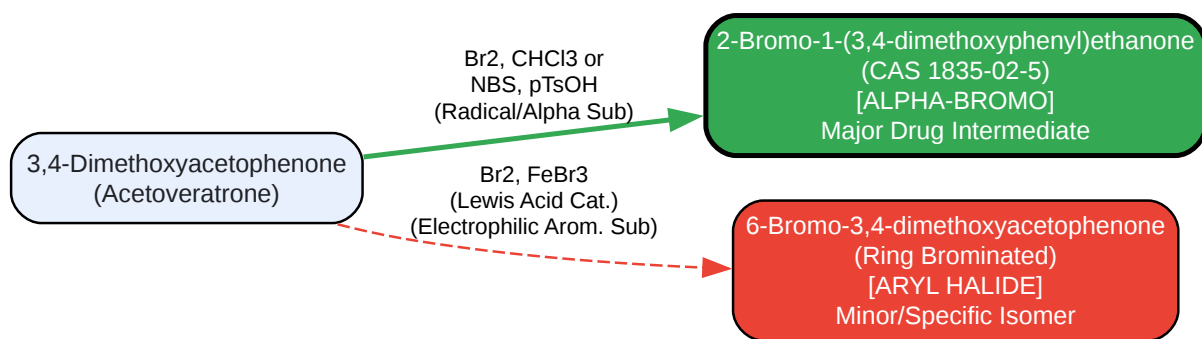

[Click to download full resolution via product page](#)

Figure 1: Divergent bromination pathways of acetoveratrone.[1][2][3][4] The green path yields the industrially relevant alpha-bromo ketone.[1][2][3]

Physical Properties Data (CAS 1835-02-5)[1][2][7]

The following data represents the purified

-bromo intermediate. Purity plays a significant role in the melting point range; crude samples often appear as brown oils or sticky solids due to residual

or poly-brominated byproducts.[1][2][3][4]

Property	Value / Range	Condition / Note
Physical State	Crystalline Solid	Often needles or plates from EtOH/Hexane.[1][2][3][4]
Appearance	White to Off-White	Turns yellow/brown upon oxidation or light exposure.[1][2][3][4]
Melting Point	81 – 83 °C	Sharp MP indicates high purity (>98%).[1][2][3][4] Lit. range: 80–90 °C.
Boiling Point	~326 °C (Predicted)	Decomposes before boiling at atm pressure.[1][2][4]
Density	1.55 g/cm ³	Predicted value.[1][2][3][4]
Solubility (High)	DCM, Chloroform, Ethyl Acetate	Ideal for extraction/reaction.[1][3][4]
Solubility (Mod)	Methanol, Ethanol	Soluble, often used for recrystallization.[1][3][4]
Solubility (Low)	Water, Hexanes	Practically insoluble in water.[1][3][4][7]
pKa	N/A (Non-ionizable)	-protons are acidic (pKa ~18-20) due to carbonyl.[1][2]

Spectral Characterization & QC Protocols

To validate the identity of the compound, specifically distinguishing it from the ring-brominated isomer, Nuclear Magnetic Resonance (NMR) is the gold standard.[1][3]

H NMR Interpretation (400 MHz,)

The diagnostic peak for the

-bromo ketone is the singlet at 4.43 ppm.[1][3] If the bromine were on the ring, this peak would appear as a methyl ketone singlet (~2.5-2.6 ppm).[1][3]

Shift (ppm)	Multiplicity	Integration	Assignment	Structural Context
7.63	Singlet (dd)	1H	Ar-H (2)	Ortho to Carbonyl (Deshielded).[1][2]
7.57	Doublet ()	1H	Ar-H (6)	Meta coupling to H-2.[1][2]
6.94	Doublet ()	1H	Ar-H (5)	Ortho to OMe (Shielded).[1][2]
4.43	Singlet	2H	-CH Br	Diagnostic Alpha-Methylene.
3.98	Singlet	6H	-OCH x2	Methoxy groups (3, 4 positions).[1][2][3][4]

Mass Spectrometry (MS)

- Ionization: ESI+ or EI.[1][2][3][4]
- Molecular Ion:
= 258/260 (1:1 ratio due to isotope pattern).[1][2][4]
- Fragmentation: Loss of
(93/95 amu) typically yields the acylium ion base peak at
(3,4-dimethoxybenzoyl cation).[1][2]

Synthesis & Handling Methodology

Synthesis Workflow (Alpha-Bromination)

The standard protocol utilizes elemental bromine in a halogenated solvent.^{[1][2][4]} This method is preferred for scalability but requires strict temperature control to prevent poly-bromination.^{[1][2][3][4]}

- Dissolution: Dissolve 1 eq. of 3,4-dimethoxyacetophenone in

or

.
- Bromination: Add 1.05 eq. of

dropwise at 0°C. The reaction is exothermic.^{[2][3][4]}
 - Note: The solution will initially turn red/orange and fade to pale yellow as

is consumed.^{[2][3][4]}
- Quench: Wash with saturated

to neutralize

.^{[2][3][4]}
- Purification: Recrystallize from Ethanol/Hexane (1:4) if the solid is colored.^{[1][2][3][4]}

Stability & Storage^{[1][2][4][8]}

- Lachrymator: Like all

-haloketones, this compound is a potent lachrymator (tear gas agent).^{[1][2][3]}
- Hydrolysis Risk: The

bond is labile.^{[1][2][3][4]} Exposure to moisture can hydrolyze the compound to the

-hydroxy ketone.^{[2][3][4]}

- Storage: Store at 2–8 °C under an inert atmosphere (Argon/Nitrogen). Protect from light to prevent radical degradation.[\[2\]](#)[\[3\]](#)[\[4\]](#)

Safety Data (SDS Highlights)

Signal Word: DANGER

- Hazard Statements:
 - H314: Causes severe skin burns and eye damage.[\[1\]](#)[\[2\]](#)[\[3\]](#)[\[4\]](#)
 - H318: Causes serious eye damage.[\[1\]](#)[\[2\]](#)[\[3\]](#)[\[4\]](#)
 - H335: May cause respiratory irritation (Lachrymator).[\[1\]](#)[\[2\]](#)[\[4\]](#)
- PPE Requirements:
 - Face shield and safety goggles (mandatory).[\[1\]](#)[\[2\]](#)[\[4\]](#)
 - Butyl rubber gloves (Nitrile may degrade with prolonged DCM exposure).[\[1\]](#)[\[2\]](#)[\[4\]](#)
 - Work strictly within a fume hood.[\[2\]](#)[\[3\]](#)[\[4\]](#)

References

- ChemicalBook. (2025).[\[1\]](#)[\[2\]](#)[\[3\]](#)[\[4\]](#) 2-Bromo-1-(3,4-dimethoxyphenyl)ethanone Properties and NMR Data. Retrieved from [\[1\]](#)[\[2\]](#)
- Sigma-Aldrich. (2025).[\[2\]](#)[\[3\]](#)[\[4\]](#) Product Specification: 2-Bromo-1-(3,4-dimethoxyphenyl)ethanone (CAS 1835-02-5).[\[1\]](#)[\[2\]](#)[\[3\]](#)[\[5\]](#) Retrieved from [\[1\]](#)[\[2\]](#)
- Royal Society of Chemistry. (2017).[\[1\]](#)[\[2\]](#)[\[3\]](#)[\[4\]](#)[\[8\]](#) Supporting Information: Synthesis of alpha-bromoketones. RSC Advances. Retrieved from
- National Institute of Standards and Technology (NIST). (2025).[\[1\]](#)[\[2\]](#)[\[3\]](#)[\[4\]](#) Mass Spectrum of Brominated Acetophenones. Retrieved from [\[1\]](#)[\[2\]](#)

Need Custom Synthesis?

BenchChem offers custom synthesis for rare earth carbides and specific isotopic labeling.

Email: info@benchchem.com or [Request Quote Online](#).

Sources

- 1. 2-BROMO-1-(3,4-DIMETHOXYPHENYL)ETHANONE | 1835-02-5 [chemicalbook.com]
- 2. 2-bromo-1-(2,5-dimethoxyphenyl)ethanone, CasNo.1204-21-3 Shanghai Minstar Chemical Co., Ltd China (Mainland) [minstar.lookchem.com]
- 3. fh至尊平台登录注册引领体育APP新潮流,打造个性化观赛体验 [ppcswitch.com]
- 4. YAKUGAKU ZASSHI [jstage.jst.go.jp]
- 5. Buy Online CAS Number 1835-02-5 - TRC - 2-Bromo-1-(3,4-dimethoxyphenyl)ethanone | LGC Standards [lgcstandards.com]
- 6. 溴代-3,4-二甲氧基苯乙酮_密度_熔点_沸点_CAS号【1835-02-5】_化源网 [chemsrc.com]
- 7. Cas 90-05-1,Guaiacol | lookchem [lookchem.com]
- 8. rsc.org [rsc.org]
- To cite this document: BenchChem. [Technical Guide: Physical Properties and Characterization of Brominated 3,4-Dimethoxyacetophenones]. BenchChem, [2026]. [Online PDF]. Available at: [<https://www.benchchem.com/product/b13580624/docs#technical-guide-physical-properties-and-characterization-of-brominated-3-4-dimethoxyacetophenones>]

Disclaimer & Data Validity:

The information provided in this document is for Research Use Only (RUO) and is strictly not intended for diagnostic or therapeutic procedures. While BenchChem strives to provide accurate protocols, we make no warranties, express or implied, regarding the fitness of this product for every specific experimental setup.

Technical Support: The protocols provided are for reference purposes. Unsure if this reagent suits your experiment?

Need Industrial/Bulk Grade? [Request Custom Synthesis Quote](#)

BenchChem

Our mission is to be the trusted global source of essential and advanced chemicals, empowering scientists and researchers to drive progress in science and industry.

Contact

Address: 3281 E Guasti Rd

Ontario, CA 91761, United States

Phone: (601) 213-4426

Email: info@benchchem.com

[Contact our Ph.D. Support Team for a compatibility check](#)