

# Comparative Guide: 5-Fluoro vs. 5-Chloro-2-methylbenzo[b]thiophene

**Author:** BenchChem Technical Support Team. **Date:** May 2026

## Compound of Interest

Compound Name: 5-Fluoro-2-methylbenzo[b]thiophene  
Cat. No.: B13566514

[Get Quote](#)

## Navigating the Halogen Effect in Thiophene Scaffolds Executive Summary

In the optimization of benzo[b]thiophene scaffolds—widely used in leukotriene inhibitors (e.g., Zileuton analogs), organic semiconductors, and kinase inhibitors—the choice between a 5-Fluoro and 5-Chloro substituent is rarely arbitrary. It represents a strategic decision between metabolic durability and synthetic versatility.

- The 5-Fluoro Analog is the "Metabolic Shield." It is primarily deployed to block oxidative metabolism at the electron-rich C5 position without significantly altering the steric profile of the parent molecule.
- The 5-Chloro Analog is the "Synthetic Handle." While it increases lipophilicity (LogP), its primary value lies in its ability to participate in Palladium-catalyzed cross-couplings (Buchwald-Hartwig, Suzuki), serving as a gateway to more complex architectures.

This guide provides a technical comparison of these two critical intermediates, supported by physical data, synthesis protocols, and reactivity profiles.

## Chemical Profile & Physical Properties[1][2][3][4][5][6]

The 2-methyl group in both analogs serves to block the highly reactive

-position of the thiophene ring, directing electrophilic substitution to the C3 position or forcing metabolism to the benzene ring.

Feature	5-Fluoro-2-methylbenzo[b]thiophene	5-Chloro-2-methylbenzo[b]thiophene
Structure	F-Substituted (C5)	Cl-Substituted (C5)
CAS Number	Precursor:[1] 154630-32-7 (Ester)Acid:[2][3] 33184-16-6 (Benzoic precursor)	30489-80-6
Molecular Weight	166.22 g/mol	182.67 g/mol
Physical State	Low-melting solid / Oil	Solid (mp -47–51 °C*)
C-X Bond Length	~1.35 Å (Strong, Metabolic Block)	~1.74 Å (Weaker, Reactive Handle)
Electronic Effect	Strong -withdrawing, -donating	Moderate -withdrawing, weak -donating
Primary Utility	Metabolic Stability (Bioisostere for H)	Intermediate (Cross-coupling partner)

\*Note: Melting points for methylated benzothiophenes vary by purity and isomer. The parent 2-methylbenzo[b]thiophene melts at 51-52°C; halogenated analogs typically fall in the 40–60°C range.

## Synthesis & Manufacturing Pathways

The synthesis of these 2-methyl analogs often bypasses direct electrophilic halogenation, which suffers from poor regioselectivity (giving mixtures of C3, C4, and C6 isomers). Instead,

de novo ring construction or decarboxylation are the preferred routes to ensure the halogen is fixed at the C5 position.

## Pathway A: The Decarboxylative Route (High Fidelity)

This is the most reliable method for generating isomerically pure material on a gram scale. It starts from the commercially available 2-carboxylic acid derivatives.

## Pathway B: Cyclization of -Arylthioacetones

A more atom-economical route involving the cyclization of thiophenols with chloroacetone or propargyl species.

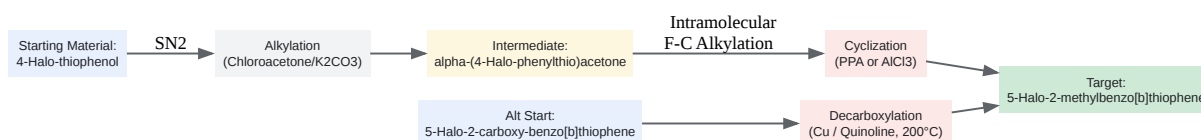

[Click to download full resolution via product page](#)

Figure 1: Two primary synthetic routes. The Decarboxylation route (bottom) is preferred for high isomeric purity.

## Performance Comparison: Decision Matrix

### A. Metabolic Stability (The Fluorine Advantage)

In drug discovery, the 5-position of the benzo[b]thiophene ring is a "soft spot" for Cytochrome P450-mediated hydroxylation.

- Mechanism: The C-H bond at C5 is electron-rich.
- Solution: Substitution with Fluorine blocks this site. The C-F bond (approx. 116 kcal/mol) is too strong for CYP450 to break. Furthermore, Fluorine's small Van der Waals radius (1.47 Å) mimics Hydrogen (1.20 Å), allowing the drug to fit into the same binding pocket while extending half-life (

).

- Use Case: Select the 5-Fluoro analog if your lead compound suffers from rapid clearance via aromatic hydroxylation.

## B. Synthetic Reactivity (The Chlorine Advantage)

The 5-Chloro analog is not a terminal modification; it is a gateway. The C-Cl bond is weak enough to undergo oxidative addition with Palladium (0) catalysts.

- Reactivity: The 5-Cl analog allows for downstream diversification at the C5 position via Suzuki-Miyaura or Buchwald-Hartwig couplings.
- Use Case: Select the 5-Chloro analog if you need to attach aryl rings, amines, or solubility-enhancing groups to the 5-position later in the synthesis.

## C. Regioselectivity of Electrophilic Substitution

Both analogs direct incoming electrophiles (e.g., bromination, acylation) to the C3 position.

- 5-Fluoro: Strongly deactivates the benzene ring but donates electron density by resonance. The C3 position remains the most nucleophilic site.
- 5-Chloro: Similar directing effect, but the resulting product is more lipophilic.

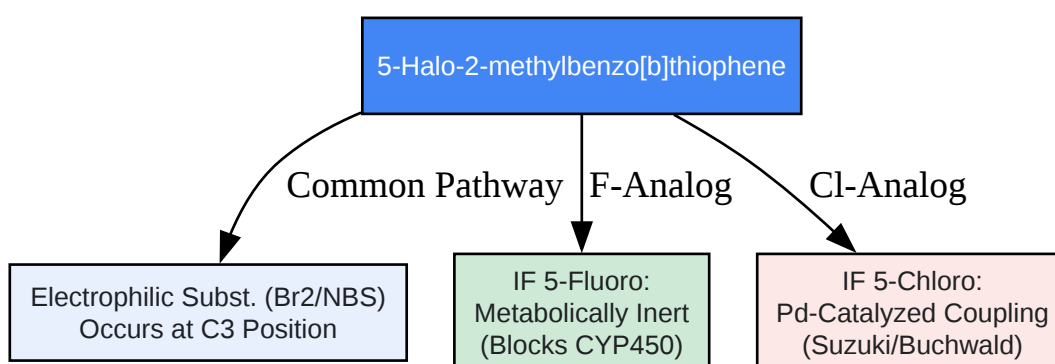

[Click to download full resolution via product page](#)

Figure 2: Divergent reactivity profiles. Note that C3 functionalization is common to both, while C5 reactivity is unique to the Chloro-analog.

## Experimental Protocol: Decarboxylation Synthesis

This protocol describes the synthesis of **5-Fluoro-2-methylbenzo[b]thiophene** from its carboxylic acid precursor. This method is chosen for its reliability in producing isomerically pure products, avoiding the separation issues of direct cyclization.

Objective: Decarboxylation of **5-fluoro-2-methylbenzo[b]thiophene-3-carboxylic acid** (or 2-carboxylic acid).

Reagents:

- Starting Material: **5-Fluoro-2-methylbenzo[b]thiophene-3-carboxylic acid** (1.0 equiv)
- Copper powder (0.1 equiv)
- Quinoline (Solvent, 5-10 volumes)<sup>[4]</sup>

Protocol:

- Setup: Equip a 3-neck round-bottom flask with a magnetic stir bar, a reflux condenser, and a nitrogen inlet.
- Charging: Add the carboxylic acid precursor and copper powder to the flask. Add Quinoline as the solvent.
- Reaction: Heat the mixture to 200–220°C (sand bath or high-temp oil bath). Evolution of CO<sub>2</sub> gas will be observed.
- Monitoring: Monitor by TLC (Hexane/EtOAc) or LC-MS. The reaction is typically complete when gas evolution ceases (approx. 2–4 hours).
- Workup:
  - Cool the mixture to room temperature.
  - Dilute with Ethyl Acetate (EtOAc) and filter through a pad of Celite to remove Copper.

- Wash the filtrate with 1N HCl (3x) to remove the Quinoline (this step is critical; Quinoline forms a salt with HCl and washes into the aqueous layer).
- Wash with Brine, dry over Na<sub>2</sub>SO<sub>4</sub>, and concentrate in vacuo.
- Purification: Purify the residue via silica gel flash chromatography (100% Hexanes to 5% EtOAc/Hexanes).
- Yield: Expect 75–85% yield of a low-melting solid or clear oil.

#### Self-Validating Check:

- NMR Verification: The disappearance of the carboxylic acid proton (>11 ppm) and the appearance of the C3-H aromatic singlet (approx. 7.0–7.3 ppm) confirms decarboxylation.

## References

- Synth. Commun. (2013). Synthesis of substituted benzo[b]thiophenes via Pd-catalyzed reactions. (General reactivity of 5-Cl analogs).
- J. Med. Chem. (2026).[5][1] Metabolic Stability of Fluorinated Small Molecules: A Physical Organic Chemistry Perspective. (Mechanistic basis for F-substitution).
- Organic Chemistry Portal.Synthesis of Benzothiophenes. (Cyclization protocols).
- PrepChem.Synthesis of 2-methylbenzo[b]thiophene-5-carboxylic acid methyl ester. (Precursor synthesis data).
- BenchChem.Comparative Biological Activity of 3-Halo-4-methylbenzo[b]thiophenes. (Antimicrobial data trends for halogenated benzothiophenes).

### Need Custom Synthesis?

BenchChem offers custom synthesis for rare earth carbides and specific isotopic labeling.

Email: [info@benchchem.com](mailto:info@benchchem.com) or [Request Quote Online](#).

## Sources

- [1. Melting point standard 47-49°C | 119-61-9 - BuyersGuideChem \[buyersguidechem.com\]](#)
- [2. 5-FLUORO-BENZO\[B\]THIOPHENE-2-CARBOXYLIC ACID METHYL ESTER CAS#: 154630-32-7 \[amp.chemicalbook.com\]](#)
- [3. calpaclab.com \[calpaclab.com\]](#)
- [4. Thieme E-Journals - Synthesis / Abstract \[thieme-connect.de\]](#)
- [5. Metabolic Stability of Fluorinated Small Molecules: A Physical Organic Chemistry Perspective - PubMed \[pubmed.ncbi.nlm.nih.gov\]](#)
- [To cite this document: BenchChem. \[Comparative Guide: 5-Fluoro vs. 5-Chloro-2-methylbenzo\[b\]thiophene\]. BenchChem, \[2026\]. \[Online PDF\]. Available at: \[https://www.benchchem.com/product/b13566514/docs#comparative-guide-5-fluoro-vs-5-chloro-2-methylbenzo-b-thiophene\]](#)

---

#### Disclaimer & Data Validity:

The information provided in this document is for Research Use Only (RUO) and is strictly not intended for diagnostic or therapeutic procedures. While BenchChem strives to provide accurate protocols, we make no warranties, express or implied, regarding the fitness of this product for every specific experimental setup.

**Technical Support:** The protocols provided are for reference purposes. Unsure if this reagent suits your experiment?

**Need Industrial/Bulk Grade?** [Request Custom Synthesis Quote](#)

## BenchChem

Our mission is to be the trusted global source of essential and advanced chemicals, empowering scientists and researchers to drive progress in science and industry.

#### Contact

Address: 3281 E Guasti Rd  
Ontario, CA 91761, United States  
Phone: (601) 213-4426  
Email: [info@benchchem.com](mailto:info@benchchem.com)

Contact our Ph.D. Support Team for a compatibility check