

(3,5-Dimethoxybenzyl)glycine: A Technical Guide for Advanced Research

Author: BenchChem Technical Support Team. **Date:** April 2026

Compound of Interest

Compound Name: (3,5-Dimethoxybenzyl)glycine

Cat. No.: B13564171

[Get Quote](#)

Abstract

Compound Identification and Nomenclature

A critical first step in the characterization of any chemical entity is its unambiguous identification. For **(3,5-Dimethoxybenzyl)glycine**, while a dedicated CAS number is not currently available, we can define its identity through its structural and molecular properties.

Identifier	Value	Source/Method
IUPAC Name	2-(((3,5-dimethoxyphenyl)methyl)amino)acetic acid	IUPAC Nomenclature
Molecular Formula	C ₁₁ H ₁₅ NO ₄	Elemental Composition
Molecular Weight	225.24 g/mol	Calculated
Canonical SMILES	<chem>COC1=CC(CNCC(=O)O)=CC(OC)=C1</chem>	Structure-to-SMILES Conversion
InChI Key	(Predicted)	InChI Generation Algorithm

It is imperative to distinguish this compound from its commercially available isomer, N-(3,4-dimethoxybenzyl)glycine, which is registered under CAS number 51527-52-7[1]. The positional difference of the methoxy groups on the benzyl ring is expected to impart distinct electronic and steric properties, potentially leading to differential biological activities and chemical reactivities.

Rationale and Proposed Synthesis: A Reductive Amination Approach

The synthesis of N-substituted glycine derivatives is a well-established area of organic chemistry. For the targeted synthesis of **(3,5-Dimethoxybenzyl)glycine**, a reductive amination pathway offers a high-yield and procedurally straightforward approach. This method is predicated on the reaction of a carbonyl compound with an amine to form an imine, which is then reduced in situ to the corresponding amine.

The proposed synthesis involves the reaction of 3,5-dimethoxybenzaldehyde with glycine. To facilitate this, the glycine is typically used as an ester (e.g., ethyl glycinate) to improve solubility in organic solvents and to prevent side reactions involving the carboxylic acid moiety.

Experimental Protocol: Synthesis of (3,5-Dimethoxybenzyl)glycine

Materials:

- 3,5-Dimethoxybenzaldehyde
- Glycine ethyl ester hydrochloride
- Sodium triacetoxyborohydride (STAB)
- Dichloromethane (DCM)
- Sodium bicarbonate (NaHCO_3)
- Magnesium sulfate (MgSO_4)
- Hydrochloric acid (HCl)

- Ethyl acetate (EtOAc)
- Hexanes

Procedure:

- **Imine Formation:** In a round-bottom flask, dissolve 3,5-dimethoxybenzaldehyde (1.0 eq) and glycine ethyl ester hydrochloride (1.1 eq) in dichloromethane. Add a mild base, such as triethylamine (1.2 eq), to neutralize the hydrochloride salt and facilitate imine formation. Stir the mixture at room temperature for 1-2 hours.
- **Reduction:** To the stirring mixture, add sodium triacetoxyborohydride (1.5 eq) portion-wise. The use of STAB is strategic as it is a mild and selective reducing agent for imines in the presence of aldehydes. Allow the reaction to proceed at room temperature for 12-24 hours, monitoring by TLC or LC-MS for the disappearance of the starting materials.
- **Work-up:** Quench the reaction by the slow addition of a saturated aqueous solution of sodium bicarbonate. Transfer the mixture to a separatory funnel and extract the aqueous layer with dichloromethane (3x). Combine the organic layers, wash with brine, and dry over anhydrous magnesium sulfate.
- **Purification of the Ester Intermediate:** Filter the drying agent and concentrate the organic phase under reduced pressure. The resulting crude **N-(3,5-dimethoxybenzyl)glycine** ethyl ester can be purified by column chromatography on silica gel using a gradient of ethyl acetate in hexanes.
- **Hydrolysis:** Dissolve the purified ester in a mixture of THF and water. Add lithium hydroxide (2.0 eq) and stir at room temperature until the hydrolysis is complete (monitored by TLC or LC-MS).
- **Final Isolation:** Acidify the reaction mixture to approximately pH 5-6 with 1M HCl. The product, **(3,5-Dimethoxybenzyl)glycine**, may precipitate and can be collected by filtration. If it remains in solution, extract with a suitable organic solvent like ethyl acetate. Dry the organic extracts and remove the solvent under reduced pressure to yield the final product.

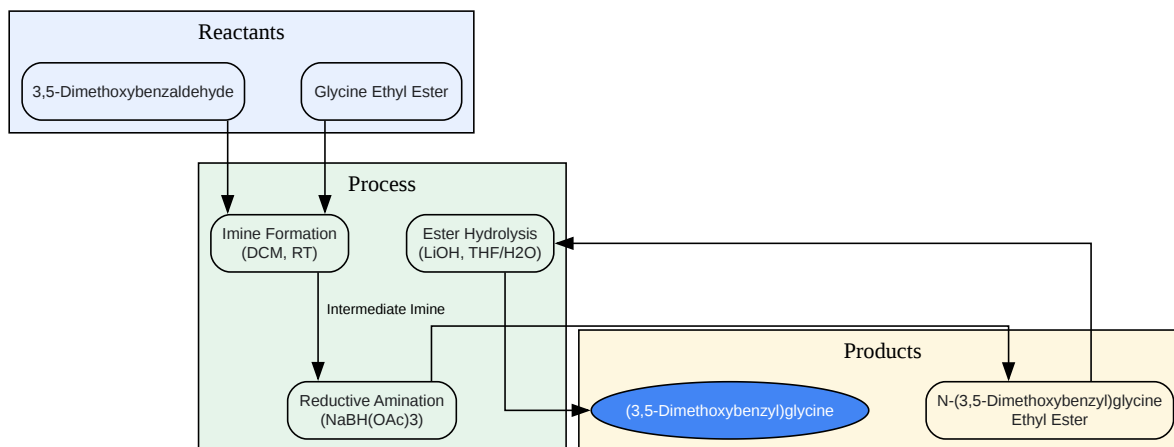

[Click to download full resolution via product page](#)

Caption: Proposed synthetic workflow for **(3,5-Dimethoxybenzyl)glycine**.

Predicted Physicochemical Properties

The physicochemical properties of a compound are critical determinants of its behavior in biological and chemical systems. The following table presents predicted properties for **(3,5-Dimethoxybenzyl)glycine** based on its structure, drawing analogies from its 3,4-isomer[1].

Property	Predicted Value	Significance in Drug Development
Molecular Weight	225.24 g/mol	Adheres to Lipinski's Rule of Five (<500 Da), favoring oral bioavailability.
XLogP3	~ -1.5	Indicates high hydrophilicity, which may affect membrane permeability but favor solubility.
Hydrogen Bond Donors	2	Contributes to solubility in aqueous media and potential for target binding.
Hydrogen Bond Acceptors	5	Influences solubility and the formation of interactions with biological targets.
Polar Surface Area	67.8 Å ²	Suggests good potential for oral absorption.

Potential Applications in Research and Drug Development

N-substituted glycine derivatives are a class of compounds with diverse applications in medicinal chemistry. The incorporation of the 3,5-dimethoxybenzyl moiety could confer unique properties relevant to several therapeutic areas.

- **Peptidomimetics and Drug Scaffolds:** The 2,4-dimethoxybenzyl (Dmb) group is utilized in peptide synthesis to reduce aggregation and improve solubility of hydrophobic peptides by disrupting backbone hydrogen bonding[2]. The 3,5-dimethoxybenzyl group could serve a similar purpose, making **(3,5-Dimethoxybenzyl)glycine** a valuable building block for the synthesis of complex peptides and peptidomimetics with enhanced properties.
- **Anticonvulsant and Neuromodulatory Agents:** Glycine is a primary inhibitory neurotransmitter in the central nervous system. N-substituted glycine derivatives have been explored for their

potential to modulate glycine receptors and transporters, with some demonstrating anticonvulsant activity. The specific substitution pattern on the benzyl ring can significantly influence potency and selectivity.

- **Anticancer Research:** The 3,4,5-trimethoxy substitution pattern on aromatic rings is a feature of several potent anticancer agents that target tubulin polymerization[3]. While having one fewer methoxy group, the 3,5-dimethoxybenzyl moiety may still confer some degree of cytotoxic or antiproliferative activity, warranting investigation in cancer cell lines.

Analytical and Quality Control Methodologies

The characterization and quality control of a newly synthesized compound are paramount. A multi-pronged analytical approach is recommended to confirm the identity and purity of **(3,5-Dimethoxybenzyl)glycine**.

Chromatographic Analysis

High-Performance Liquid Chromatography (HPLC) is the preferred method for assessing the purity of the final compound and for monitoring reaction progress.

- **Recommended Column:** A C18 reverse-phase column is suitable for this polar compound.
- **Mobile Phase:** A gradient elution using a mixture of an aqueous buffer (e.g., 0.1% formic acid or ammonium acetate) and an organic solvent (e.g., acetonitrile or methanol) is recommended.
- **Detection:** UV detection at a wavelength corresponding to the absorbance maximum of the dimethoxybenzyl chromophore (typically around 270-280 nm) should be employed.

Spectroscopic Characterization

- **Nuclear Magnetic Resonance (NMR) Spectroscopy:** ^1H and ^{13}C NMR are essential for structural elucidation. The proton NMR spectrum is expected to show characteristic signals for the aromatic protons of the 3,5-disubstituted ring, the methoxy groups, the benzylic methylene protons, and the glycine methylene protons.
- **Mass Spectrometry (MS):** High-resolution mass spectrometry (HRMS) should be used to confirm the elemental composition by providing a highly accurate mass measurement of the

molecular ion.

Safety and Handling

As **(3,5-Dimethoxybenzyl)glycine** is a novel compound, comprehensive toxicity data is not available. Therefore, it should be handled with the standard precautions for a new chemical entity.

- Personal Protective Equipment (PPE): Wear appropriate PPE, including safety glasses, a lab coat, and chemical-resistant gloves.
- Handling: Handle in a well-ventilated area, preferably within a chemical fume hood, to avoid inhalation of any dust or aerosols.
- Storage: Store in a tightly sealed container in a cool, dry place away from incompatible materials such as strong oxidizing agents.

A general assessment of risk can be inferred from the parent molecules. Glycine is a non-hazardous substance. 3,5-Dimethoxybenzylamine, a related precursor, should be handled with care.

Conclusion

(3,5-Dimethoxybenzyl)glycine represents an intriguing yet underexplored molecule with significant potential as a building block in peptide synthesis and as a scaffold in medicinal chemistry. While the absence of a registered CAS number underscores its novelty, this guide provides a robust framework for its synthesis, characterization, and initial exploration. By leveraging established synthetic methodologies and predictive science, researchers are well-equipped to unlock the potential of this promising compound.

References

- PubChem. N-(3,4-dimethoxybenzyl)glycine. National Center for Biotechnology Information. [\[Link\]](#)
- PubChem. N-(4-Hydroxy-3,5-dimethoxybenzoyl)glycine. National Center for Biotechnology Information. [\[Link\]](#)

- Frontiers in Bioengineering and Biotechnology. Heterologous Production of Glycine Betaine Using Synechocystis sp. PCC 6803-Based Chassis Lacking Native Compatible Solutes. [\[Link\]](#)
- Carl ROTH. Safety Data Sheet: Glycine. [\[Link\]](#)
- Aapptec. NEW Fmoc-AA-(DMB)GLY DIPEPTIDES. [\[Link\]](#)
- Google Patents. Method for synthesizing peptide containing n-substituted amino acid.
- PMC. Green Synthesis and Bioactivity of Aliphatic N-Substituted Glycine Derivatives. [\[Link\]](#)
- RSC Publishing. Design, synthesis and biological evaluation of 3',4',5'-trimethoxy flavonoid benzimidazole derivatives as potential anti-tumor agents. [\[Link\]](#)

Need Custom Synthesis?

BenchChem offers custom synthesis for rare earth carbides and specific isotopic labeling.

Email: info@benchchem.com or [Request Quote Online](#).

Sources

- 1. N-(3,4-dimethoxybenzyl)glycine | C₁₁H₁₅NO₄ | CID 13236082 - PubChem [\[pubchem.ncbi.nlm.nih.gov\]](https://pubchem.ncbi.nlm.nih.gov)
- 2. peptide.com [\[peptide.com\]](https://peptide.com)
- 3. researchgate.net [\[researchgate.net\]](https://researchgate.net)
- To cite this document: BenchChem. [(3,5-Dimethoxybenzyl)glycine: A Technical Guide for Advanced Research]. BenchChem, [2026]. [Online PDF]. Available at: [\[https://www.benchchem.com/product/b13564171/docs#3-5-dimethoxybenzyl-glycine-a-technical-guide-for-advanced-research\]](https://www.benchchem.com/product/b13564171/docs#3-5-dimethoxybenzyl-glycine-a-technical-guide-for-advanced-research)

Disclaimer & Data Validity:

The information provided in this document is for Research Use Only (RUO) and is strictly not intended for diagnostic or therapeutic procedures. While BenchChem strives to provide

accurate protocols, we make no warranties, express or implied, regarding the fitness of this product for every specific experimental setup.

Technical Support: The protocols provided are for reference purposes. Unsure if this reagent suits your experiment?

Need Industrial/Bulk Grade? [Request Custom Synthesis Quote](#)

BenchChem

Our mission is to be the trusted global source of essential and advanced chemicals, empowering scientists and researchers to drive progress in science and industry.

Contact

Address: 3281 E Guasti Rd

Ontario, CA 91761, United States

Phone: (601) 213-4426

Email: info@benchchem.com

[Contact our Ph.D. Support Team for a compatibility check](#)