

# Technical Support Center: Thermal Handling of 2-(Aminomethyl)hexan-1-ol

**Author:** BenchChem Technical Support Team. **Date:** April 2026

## Compound of Interest

Compound Name: 2-(Aminomethyl)hexan-1-ol

Cat. No.: B13563675

[Get Quote](#)

## Executive Summary

**2-(Aminomethyl)hexan-1-ol** is a 1,3-amino alcohol.<sup>[1][2][3]</sup> Unlike 1,2-amino alcohols which readily form 5-membered rings, this molecule's 1,3-substitution pattern predisposes it to form 6-membered heterocycles (1,3-oxazinanes) upon heating or improper storage. The "cyclization" users typically observe is not a simple thermal dehydration but often a chemically catalyzed reaction with impurities (aldehydes) or atmospheric

This guide details the mechanistic causes of these transformations and provides self-validating protocols to prevent them.

## Part 1: Mechanistic Diagnostics (Root Cause Analysis)

To prevent cyclization, one must first identify which pathway is active. The three primary degradation modes are:

### The "Carbamate" Pathway (Atmospheric Capture)

- Cause: 1,3-amino alcohols are potent

scrubbers. Upon heating in an open system or storage without an inert seal, they react with to form a cyclic carbamate (5-butyl-1,3-oxazinan-2-one).

- Symptom: The liquid becomes viscous, cloudy, or precipitates a white solid that does not dissolve in the parent liquid.
- Mechanism:

.

## The "Oxazine" Pathway (Oxidative Impurity)

- Cause: If the alcohol is heated in the presence of air, partial oxidation generates an aldehyde in situ. The amine then condenses with this aldehyde to form a tetrahydro-1,3-oxazine.
- Symptom: Yellowing of the liquid and the appearance of a "doublet" impurity in GC/NMR (diastereomers of the oxazine).

## The "Azetidine" Pathway (Thermal Dehydration)

- Cause: Extreme heat (>160°C) or the presence of acidic catalysts (e.g., silica residue, metal salts) can force an intramolecular reaction, expelling water to form a strained 4-membered azetidine.
- Symptom: A lower-boiling impurity that smells distinctively pungent/ammoniacal.

## Pathway Visualization

The following diagram maps the degradation logic. Use this to diagnose your specific impurity profile.

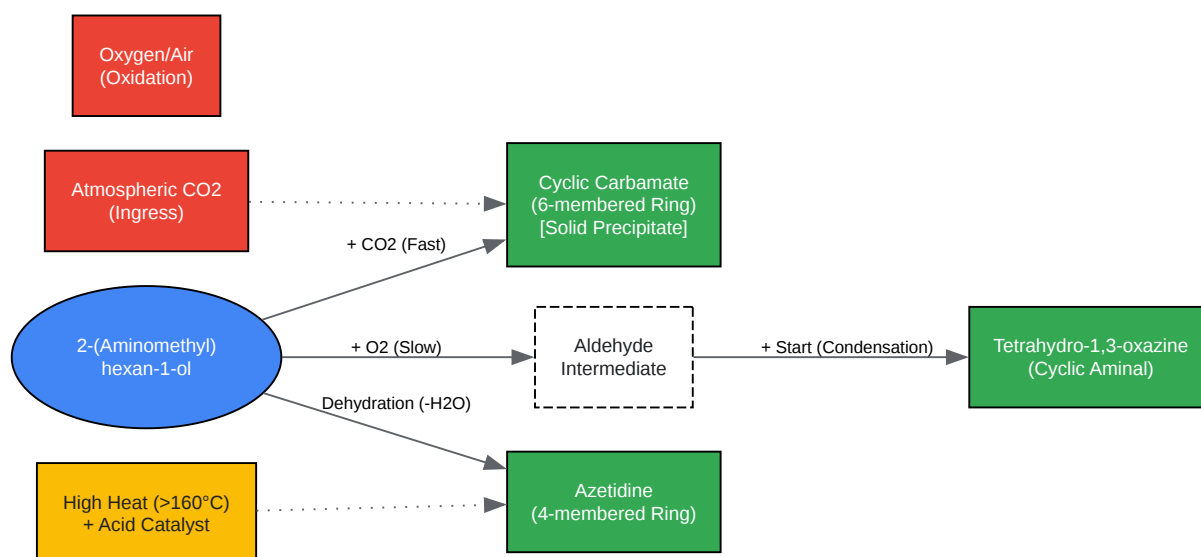

[Click to download full resolution via product page](#)

Caption: Figure 1. Thermal and chemical degradation pathways of 1,3-amino alcohols. The Carbamate pathway is the most common "cyclization" error.

## Part 2: Troubleshooting Guide (FAQs)

### Q1: I am distilling the product, but the boiling point keeps rising and the viscosity is increasing. Is it polymerizing?

Diagnosis: Likely Cyclic Carbamate Formation or Dimerization. If you are distilling under vacuum but have a small leak, or if the apparatus was not purged with Argon, atmospheric is reacting with the distilling vapor. The cyclic carbamate has a much higher boiling point than the free amino alcohol.

- Immediate Action: Stop the distillation. Check the vacuum seal. Repurge the system with Argon.

- Prevention: Use a Schlenk line or a distillation setup with a drying tube on the vacuum release valve to scrub

## Q2: Can I use silica gel chromatography to purify this?

Diagnosis: Risk of Azetidine/Rearrangement. Amino alcohols stick avidly to silica due to the amine group. To elute them, researchers often use methanol/ammonia. However, the acidic nature of silica can catalyze the Azetidine formation (intramolecular dehydration) or simply trap the molecule.

- Recommendation: Avoid silica if possible. Use Distillation (see Protocol A) or Amine-functionalized silica. If standard silica is necessary, pre-treat the column with 2% Triethylamine in Hexane to neutralize acidic sites.

## Q3: My NMR shows a new set of signals after heating at 120°C. Is this the azetidine?

Diagnosis: Check for Oxazine. Azetidine formation is thermodynamically difficult (strained 4-membered ring). If you see a methylene signal splitting into a complex pattern near 4.0-4.5 ppm, it is likely the Tetrahydro-1,3-oxazine formed by condensation with trace formaldehyde or self-oxidation products.

- Validation: Add a drop of and trace acid to the NMR tube. Oxazines often hydrolyze back to the open chain and aldehyde, whereas azetidines are stable to mild hydrolysis.

## Part 3: Validated Protocols

### Protocol A: "Cyclization-Free" Distillation

Objective: Purify **2-(Aminomethyl)hexan-1-ol** without thermal degradation.

Prerequisites:

- High Vacuum Pump (<1 mbar essential).

- Short-path distillation head (minimizes residence time).
- Argon/Nitrogen balloon.

Step	Action	Scientific Rationale
1	Basify Precursor	If the crude material comes from a reduction (e.g., LiAlH <sub>4</sub> ), ensure it is fully quenched with NaOH (1M), not water/acid. Residual acid catalyzes dehydration to azetidine.
2	Degas System	Flush the distillation apparatus with Argon for 10 minutes before heating.
3	Vacuum Application	Apply full vacuum (<1 mbar). Do not heat yet.
4	Ramp Heating	Heat the oil bath slowly. The bath temp should not exceed 140°C.
5	Fraction Collection	Discard the first 5% (fore-run). Collect the main fraction.
6	Storage	Backfill with Argon. Seal with Parafilm/Teflon tape.

## Protocol B: Removing Cyclic Carbamate Impurities

Objective: Recover the amino alcohol if it has already cyclized with

If your material has turned cloudy or solid:

- Dissolve the material in 2M NaOH (aqueous).

- Heat to 80°C for 2 hours. (This hydrolyzes the cyclic carbamate back to the amino alcohol + carbonate).
- Extract continuously with Dichloromethane (DCM) or Toluene.
- Dry organic layer over  
  
and distill per Protocol A.

## References

- Cyclization of 1,3-Amino Alcohols with CO<sub>2</sub>
  - Title: Carbon dioxide-based facile synthesis of cyclic carbamates from amino alcohols.[4]
  - Source: Niemi, T. et al. Green Chemistry, 2018.
  - Relevance: Establishes that 1,3-amino alcohols react with to form 6-membered cyclic carbamates, often mistaken for thermal degrad
  - URL:[[Link](#)]
- Thermal Stability & Dehydration
  - Title: Amino-alcohol cyclization: selective synthesis of lactams and cyclic amines.
  - Source:C
  - Relevance: Discusses the catalytic requirements for cyclizing amino alcohols. Confirms that simple heating is often insufficient for azetidine formation without specific catalysts (Ru/Ir)
  - URL:[[Link](#)]
- General Reactivity of 1,3-Amino Alcohols
  - Title: 1,3-Amino alcohols and their phenol analogs in heterocyclization reactions.[3]
  - Source:ResearchG
  - Relevance: Provides a comprehensive overview of the heterocycles formed by 1,3-amino alcohols (oxazines, oxazinones) and the conditions required.
  - URL:[[Link](#)]

- Azetidine Synthesis via Activation
  - Title: Azetidine synthesis by La(OTf)<sub>3</sub>-catalyzed intramolecular regioselective aminolysis. [5]
  - Source:Frontiers in Chemistry, 2023.
  - Relevance: Highlights that forming the 4-membered ring (azetidine) usually requires Lewis acid catalysis (La(OTf)<sub>3</sub>)
  - URL:[[Link](#)]

### Need Custom Synthesis?

BenchChem offers custom synthesis for rare earth carbides and specific isotopic labeling.

Email: [info@benchchem.com](mailto:info@benchchem.com) or [Request Quote Online](#).

## Sources

- [1. researchgate.net \[researchgate.net\]](#)
- [2. 1,3-amino alcohol synthesis by hydroxylation \[organic-chemistry.org\]](#)
- [3. triggered.stanford.clockss.org \[triggered.stanford.clockss.org\]](#)
- [4. researchgate.net \[researchgate.net\]](#)
- [5. Frontiers | Azetidine synthesis by La\(OTf\)<sub>3</sub>-catalyzed intramolecular regioselective aminolysis of cis-3,4-epoxy amines \[frontiersin.org\]](#)
- To cite this document: BenchChem. [Technical Support Center: Thermal Handling of 2-(Aminomethyl)hexan-1-ol]. BenchChem, [2026]. [Online PDF]. Available at: [<https://www.benchchem.com/product/b13563675/docs#technical-support-center-thermal-handling-of-2-aminomethyl-hexan-1-ol>]

---

### Disclaimer & Data Validity:

The information provided in this document is for Research Use Only (RUO) and is strictly not intended for diagnostic or therapeutic procedures. While BenchChem strives to provide accurate protocols, we make no warranties, express or implied, regarding the fitness of this product for every specific experimental setup.

**Technical Support:** The protocols provided are for reference purposes. Unsure if this reagent suits your experiment?

**Need Industrial/Bulk Grade?** [Request Custom Synthesis Quote](#)

## BenchChem

Our mission is to be the trusted global source of essential and advanced chemicals, empowering scientists and researchers to drive progress in science and industry.

### Contact

Address: 3281 E Guasti Rd  
Ontario, CA 91761, United States  
Phone: (601) 213-4426  
Email: [info@benchchem.com](mailto:info@benchchem.com)

[Contact our Ph.D. Support Team for a compatibility check](#)