

Potential Biological Activity of Fluorinated Azetidine Compounds

Author: BenchChem Technical Support Team. **Date:** April 2026

Compound of Interest

Compound Name: *3-(3-Fluoro-4-methoxybenzyl)azetidin-3-ol*

Cat. No.: *B13560699*

[Get Quote](#)

Executive Summary

Fluorinated azetidines represent a high-value structural motif in modern drug discovery, acting as "conformational locks" that modulate the physicochemical properties of bioactive molecules. [1] Unlike their non-fluorinated counterparts, these four-membered heterocycles offer a unique combination of reduced basicity, enhanced metabolic stability, and bioisosteric utility.[1] This guide analyzes the structural rationale for deploying fluorinated azetidines, specifically focusing on the 3-fluoro- and 3,3-difluoroazetidine cores, and provides actionable protocols for their synthesis and validation.[1]

Structural & Physicochemical Rationale

The incorporation of fluorine into the azetidine ring is not merely a steric modification; it is an electronic calibration of the molecule. The high electronegativity of fluorine (3.98 Pauling scale) induces significant changes in the pKa and lipophilicity of the azetidine amine.

The Fluorine Effect on Basicity (pKa)

Unsubstituted azetidine is a strong base (pKa ~11.3), which can lead to poor membrane permeability and high efflux liability at physiological pH. Fluorination at the 3-position leverages the inductive effect (-I) to pull electron density away from the nitrogen lone pair, drastically lowering the pKa.

| Compound | Structure | pKa (approx.) [2][3][4][5][6] | LogP (Lipophilicity) | Electronic Effect |
|---------------------------|-----------|----------------------------------|-------------------------|---|
| Azetidine | | 11.3 | 0.20 | High basicity; prone to cation trapping. |
| 3-Fluoroazetidine | | ~8.5 - 9.0 | 0.45 | Moderate basicity; balanced permeability. |
| 3,3- Difluoroazetidine | | ~6.0 - 6.5 | 0.65 | Low basicity; neutral at physiological pH. [3] |

Key Insight: The 3,3-difluoroazetidine motif brings the basicity down to a range (pKa ~6) where a significant fraction of the molecule remains uncharged at physiological pH (7.4), thereby enhancing passive membrane permeability compared to the parent azetidine.

Bioisosterism and Conformational Locking

The 3,3-difluoroazetidine ring serves as a bioisostere for two common functionalities:

- Carbonyl Group (C=O): The polarized C-F bonds mimic the electronic distribution of a carbonyl oxygen while removing the metabolic liability of hydrolysis.
- Gem-dimethyl Group (C(Me)₂): It provides similar steric bulk but with altered polarity.[3]

Furthermore, the gauche effect—a stereoelectronic preference for

and

orbitals to align—forces the ring into a specific "puckered" conformation.[7] This reduces the entropic penalty upon binding to a protein target, effectively "pre-organizing" the ligand.

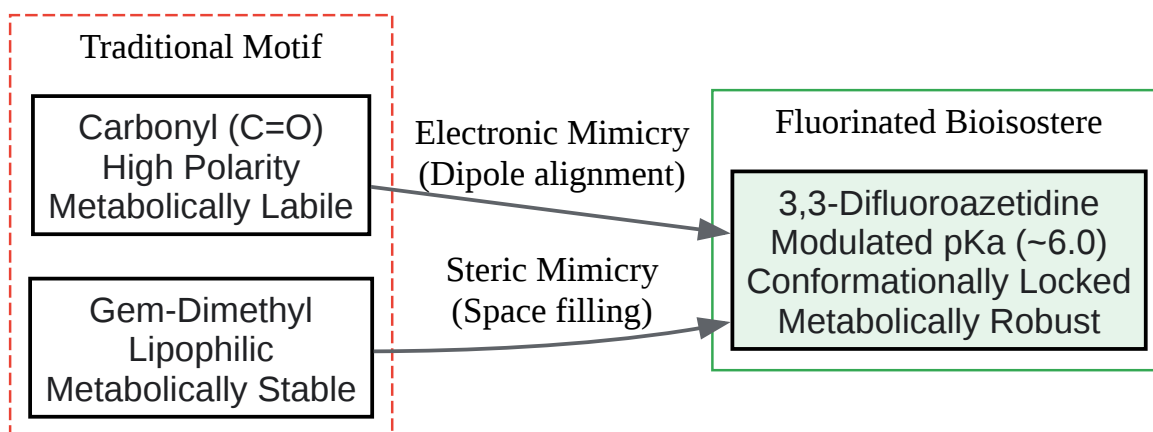

[Click to download full resolution via product page](#)

Figure 1: Bioisosteric mapping showing how 3,3-difluoroazetidine bridges the gap between polar carbonyls and lipophilic alkyl groups.

Synthetic Access: The Reformatsky Route

For drug development, scalable access to the building block is critical.[1] The most robust method for synthesizing 3,3-difluoroazetidine derivatives is the Reformatsky-type cyclization, which avoids the use of hazardous DAST reagents on sensitive amine precursors.[1]

Workflow Diagram

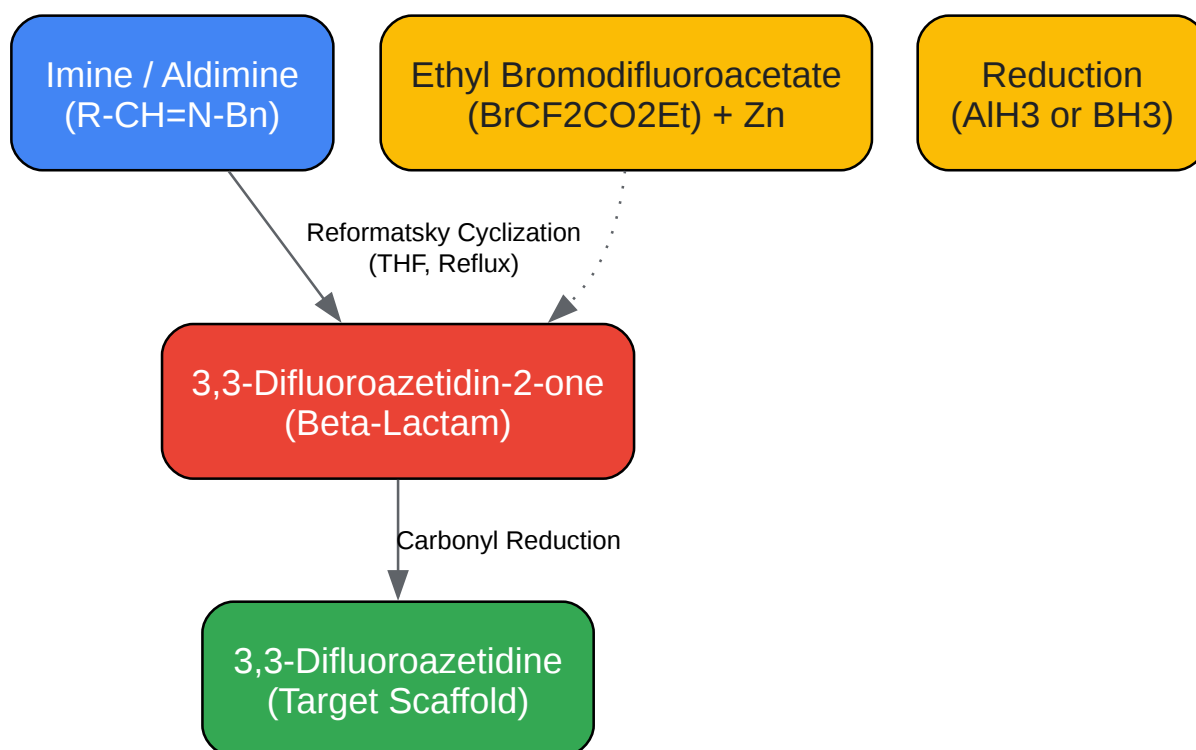

[Click to download full resolution via product page](#)

Figure 2: The Reformatsky-type synthesis pathway provides a scalable route to the 3,3-difluoroazetidine core via a stable beta-lactam intermediate.

Biological Case Studies & Therapeutic Applications

Modulation of hERG Liability

A common failure mode in drug discovery is hERG channel inhibition, often driven by basic amines and lipophilic aromatic rings.^{[1][3]}

- Mechanism: Replacing a piperidine or pyrrolidine linker with a 3,3-difluoroazetidine lowers the basicity ($pK_a < 7$), reducing the fraction of cationic species at physiological pH.^[1]
- Outcome: This reduces the electrostatic interaction with the hERG channel pore, potentially improving the cardiac safety margin.

Metabolic Stability (The "Fluorine Wall")

The C-F bond is the strongest single bond in organic chemistry (~116 kcal/mol).

- Application: In molecules like Cobimetinib (which utilizes a piperidine-azetidine scaffold), the azetidine ring is metabolically robust.[1][3] However, in analogs where the azetidine ring itself is susceptible to oxidative metabolism (e.g., N-dealkylation or ring oxidation), fluorination at the C3 position blocks the metabolic "soft spot," preventing cytochrome P450-mediated degradation.[1]

Energetic Materials & Dyes

Beyond pharma, the 3,3-difluoroazetidine hydrochloride salt (CAS: 288315-03-7) is utilized in:

- Bioimaging: As a precursor for Rhodamine dyes, where the electron-withdrawing fluorine tunes the HOMO-LUMO gap, shifting fluorescence wavelengths.[1][8]
- Energetic Materials: The high ring strain (~27 kcal/mol) combined with the density provided by fluorine makes it a candidate for high-energy density materials.[3][8]

Experimental Protocol: Synthesis of 3,3-Difluoroazetidine HCl

Objective: Synthesis of 3,3-difluoroazetidine hydrochloride from N-benzyl-3,3-difluoroazetidin-2-one.

Reagents:

- N-benzyl-3,3-difluoroazetidin-2-one (1.0 eq)[3]
- Monochloroalane () or Lithium Aluminum Hydride ()
- Anhydrous Ether () or THF
- HCl in Dioxane (4M)

Step-by-Step Methodology:

- Reduction Setup:
 - Flame-dry a 250 mL round-bottom flask and purge with Argon.[3]
 - Add

(2.0 eq) suspended in anhydrous ether at 0°C.
 - Critical Step: Add

(0.6 eq) cautiously to generate the mixed hydride species (if using mixed hydride protocol) or proceed with straight LAH if the lactam is not overly hindered.
- Addition:
 - Dissolve N-benzyl-3,3-difluoroazetid-2-one in anhydrous ether.
 - Add dropwise to the hydride suspension at 0°C.
 - Allow to warm to room temperature and reflux for 4 hours. Monitor by TLC (stain with KMnO₄; azetidines stain poorly, so look for disappearance of starting material).[1]
- Quench & Workup:
 - Cool to 0°C. Quench sequentially with water (mL), 15% NaOH (mL), and water (mL) (Fieser workup).
 - Filter the granular aluminum salts through a celite pad.[3]
 - Dry the filtrate over

and concentrate carefully (azetidines are volatile).[3]
- Debenzylation (Hydrogenolysis):

- Dissolve the N-benzyl intermediate in Methanol.
- Add Pd/C (10% w/w) and stir under atmosphere (balloon pressure) for 12 hours.
- Filter through celite.[1][3]
- Salt Formation:
 - Cool the filtrate to 0°C.[3]
 - Add HCl in Dioxane (4M) dropwise until pH < 2.[3]
 - Concentrate in vacuo to yield 3,3-difluoroazetidinium hydrochloride as a white, hygroscopic solid.[1][3]

Validation:

- ¹H NMR (): Look for a triplet at ~4.5 ppm (coupling).[3]
- ¹⁹F NMR: Expect a singlet or triplet depending on decoupling, typically around -100 ppm.[1][3]

Future Outlook

The field is moving toward chiral 3-fluoroazetidines.[3] While 3,3-difluoroazetidinium is achiral, the mono-substituted 3-fluoroazetidinium possesses a stereocenter.[1] Future drug candidates will likely exploit the specific vector of the C-F bond in the 3-fluoro variant to make precise H-bond contacts within a receptor pocket, further refining potency and selectivity beyond what is possible with the achiral difluoro-analog.

References

- Synthesis of 3,3-Difluoroazetidines: Van Brabandt, W., & De Kimpe, N. (2006).[1][3] Synthesis of 3,3-difluoroazetidines and their application in the preparation of 3,3-difluoro-beta-lactams. Journal of Organic Chemistry.
- Metabolic Stability & Bioisosterism: Meanwell, N. A. (2018).[1][3] Fluorine and Fluorinated Motifs in the Design and Application of Bioisosteres for Drug Design. Journal of Medicinal Chemistry.
- Physical Properties of Fluorinated Amines: Morgenthaler, M., et al. (2007).[1][3] Predicting and Tuning Physicochemical Properties in Lead Optimization: Amine Basicities. ChemMedChem.
- Cobimetinib Structure & Mechanism: Rice, K. D., et al. (2012).[1][3] Novel Carboxamide-Based Allosteric MEK Inhibitors: Discovery and Optimization Efforts Leading to Cobimetinib. ACS Medicinal Chemistry Letters.
- 3,3-Difluoroazetidine HCl Product Data: Ossila. (n.d.). 3,3-Difluoroazetidine hydrochloride Specifications.

Need Custom Synthesis?

BenchChem offers custom synthesis for rare earth carbides and specific isotopic labeling.

Email: info@benchchem.com or [Request Quote Online](#).

Sources

- 1. [medchemexpress.com](https://www.medchemexpress.com) [[medchemexpress.com](https://www.medchemexpress.com)]
- 2. [3,3-Difluoroazetidine HCl | 3,3-Difluoroazetidine hydrochloride | Azetidines | Ambeed.com](#) [[ambeed.com](https://www.ambeed.com)]
- 3. [3,3-二氟三甲叉亚胺 盐酸盐 97% | Sigma-Aldrich](#) [[sigmaaldrich.com](https://www.sigmaaldrich.com)]
- 4. [researchgate.net](https://www.researchgate.net) [[researchgate.net](https://www.researchgate.net)]
- 5. [medchemexpress.com](https://www.medchemexpress.com) [[medchemexpress.com](https://www.medchemexpress.com)]
- 6. [mdpi.com](https://www.mdpi.com) [[mdpi.com](https://www.mdpi.com)]

- 7. The distinct conformational landscapes of 4S-substituted prolines that promote an endo ring pucker - PMC [[pmc.ncbi.nlm.nih.gov](https://pubmed.ncbi.nlm.nih.gov/)]
- 8. ossila.com [ossila.com]
- To cite this document: BenchChem. [Potential Biological Activity of Fluorinated Azetidine Compounds]. BenchChem, [2026]. [Online PDF]. Available at: [<https://www.benchchem.com/product/b13560699/docs#potential-biological-activity-of-fluorinated-azetidine-compounds>]

Disclaimer & Data Validity:

The information provided in this document is for Research Use Only (RUO) and is strictly not intended for diagnostic or therapeutic procedures. While BenchChem strives to provide accurate protocols, we make no warranties, express or implied, regarding the fitness of this product for every specific experimental setup.

Technical Support: The protocols provided are for reference purposes. Unsure if this reagent suits your experiment?

Need Industrial/Bulk Grade? [Request Custom Synthesis Quote](#)

BenchChem

Our mission is to be the trusted global source of essential and advanced chemicals, empowering scientists and researchers to drive progress in science and industry.

Contact

Address: 3281 E Guasti Rd
Ontario, CA 91761, United States
Phone: (601) 213-4426
Email: info@benchchem.com

[Contact our Ph.D. Support Team for a compatibility check](#)

