

# Comprehensive Technical Guide: Mass Spectrometry of 4-(1-methoxyethyl)-1H-pyrazole

**Author:** BenchChem Technical Support Team. **Date:** April 2026

## Compound of Interest

Compound Name: 4-(1-methoxyethyl)-1H-pyrazole

Cat. No.: B13559992

[Get Quote](#)

## Part 1: Executive Technical Summary

Target Analyte: **4-(1-methoxyethyl)-1H-pyrazole** CAS Registry: 126.16 Da (Monoisotopic Mass) Molecular Formula:

[1]

This guide provides a rigorous analysis of the mass spectrometric behavior of **4-(1-methoxyethyl)-1H-pyrazole**, a critical intermediate in the synthesis of JAK inhibitors and other heterocyclic APIs. The presence of a basic pyrazole core coupled with a labile benzylic-like ether substituent creates distinct ionization and fragmentation signatures essential for impurity profiling and metabolite identification.

## Key Mass Spectrometric Signatures

Parameter	Value/Observation
Monoisotopic Mass	126.0793 Da
ESI(+) Precursor	127.087
Dominant ESI Fragment	95.06 , (Vinylpyrazole cation)
EI Molecular Ion	126
Key EI Fragments	111 (Loss of ) 95 (Loss of )

## Part 2: Structural Analysis & Ionization Physics

### Molecular Architecture

The molecule consists of a 1H-pyrazole ring substituted at the C4 position with a 1-methoxyethyl group.[2]

- Protonation Sites: The N2 nitrogen (pyridine-like) is the primary site of protonation in ESI, with a predicted pKa  
2.5–3.0.
- Labile Sites: The ether linkage (C-O bond) at the secondary carbon is susceptible to cleavage, particularly under Collision-Induced Dissociation (CID).

### Ionization Modalities

#### Electrospray Ionization (ESI)

In positive mode (ESI+), the molecule readily forms the

ion at

127. Due to the stability of the aromatic pyrazole system, in-source fragmentation is generally low unless high cone voltages (>30V) are applied.

- Adducts: In ammonium-buffered mobile phases,

is rarely observed due to the high proton affinity of the pyrazole nitrogen, which favors protonation over ammoniation. Sodium adducts

(

149) may appear in non-acidic conditions.

## Electron Ionization (EI)

Under 70 eV EI, the molecular ion (

,

126) is observable but often undergoes rapid

-cleavage driven by the ether oxygen and the aromatic ring stability.

## Part 3: Fragmentation Mechanisms (The Core)

### ESI-MS/MS Fragmentation Pathway (CID)

The fragmentation of the protonated precursor (

127) is dominated by a neutral loss mechanism.

- Primary Pathway (Neutral Loss of Methanol): The protonated ether oxygen facilitates the cleavage of the C-O bond. A hydrogen transfer (likely from the

-methyl or the pyrazole NH) leads to the elimination of neutral methanol (32 Da).

- Transition:

- Structure: The resulting ion at

95 is the 4-vinyl-1H-pyrazole cation. This is the base peak in MS/MS spectra due to the high stability of the conjugated vinyl-pyrazole system.

- Secondary Pathway (Ring Fragmentation): The

95 ion undergoes further fragmentation at higher collision energies (CE > 35 eV), typically losing HCN (27 Da) from the pyrazole ring.

- Transition:
- Mechanism: Ring opening and expulsion of HCN is characteristic of N-heterocycles.

## EI Fragmentation Pathway

In EI, radical-driven mechanisms prevail:

- -Cleavage: Homolytic cleavage of the C-C bond adjacent to the ether oxygen.
  - Loss of Methyl Radical ( ): Yields 111.
- C-O Bond Cleavage:
  - Loss of Methoxy Radical ( ): Yields 95 (stabilized benzylic-type cation).

## Visualization of Fragmentation Pathways

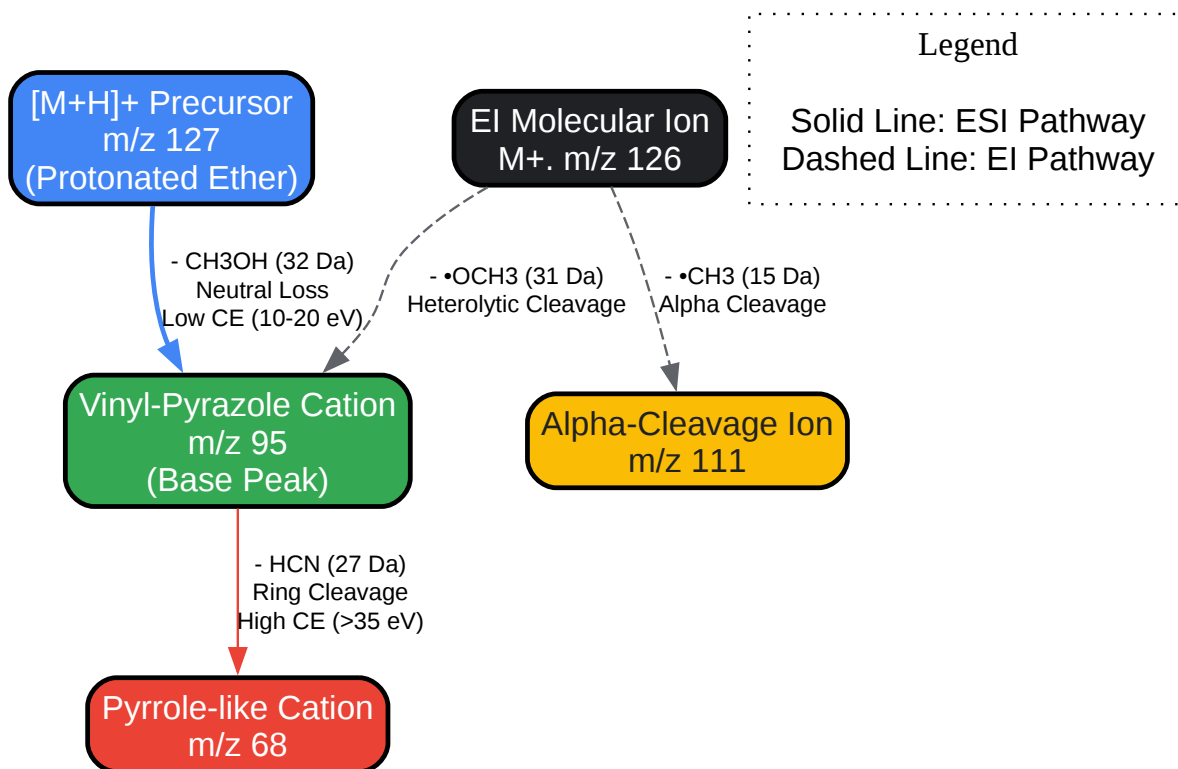

[Click to download full resolution via product page](#)

Caption: Figure 1. Comparative fragmentation pathways for ESI (blue/solid) and EI (black/dashed) ionization modes. The formation of the vinyl-pyrazole cation (m/z 95) is a convergent node.

## Part 4: Method Development Protocol

For accurate quantification and identification in complex matrices (e.g., plasma or reaction mixtures), the following LC-MS methodology is recommended.

### Chromatographic Conditions

The polarity of **4-(1-methoxyethyl)-1H-pyrazole** requires careful column selection to ensure retention.

- Stationary Phase: C18 columns are generally suitable, but "Aq" type (polar-embedded) columns are superior for preventing pore dewetting with highly aqueous mobile phases.

- Recommended: Waters XSelect HSS T3 or Phenomenex Kinetex Biphenyl.
- Mobile Phase pH:
  - Acidic (pH 2-3): Formic acid (0.1%). The pyrazole is fully protonated ( ), improving ESI sensitivity but potentially reducing retention on C18.
  - Basic (pH 9-10): Ammonium bicarbonate. The pyrazole is neutral (deprotonated), significantly increasing retention. Note: Ensure your column is pH stable.

## Mass Spectrometry Parameters (Triple Quadrupole)

Parameter	Setting	Rationale
Ionization	ESI Positive	Basic nitrogen facilitates proton capture.
Capillary Voltage	2.5 - 3.0 kV	Moderate voltage prevents discharge; analyte is easily ionized.
Cone Voltage	20 V	Optimize to maximize 127 transmission without in-source fragmentation.
Source Temp	150°C	Sufficient for solvent evaporation; analyte is thermally stable.
Desolvation Temp	400°C	Ensures complete droplet evaporation.

## MRM Transitions for Quantification

For quantitative assays (PK/PD studies), use Multiple Reaction Monitoring (MRM).

- Quantifier:  
(CE: 15-20 eV).

- Why: High intensity, clean baseline.[3]
- Qualifier:  
(CE: 35-40 eV).
  - Why: Confirms the pyrazole ring structure; prevents false positives from isobaric interferences.

## Part 5: Experimental Workflow Decision Tree

The following logic gate ensures data integrity during method development.

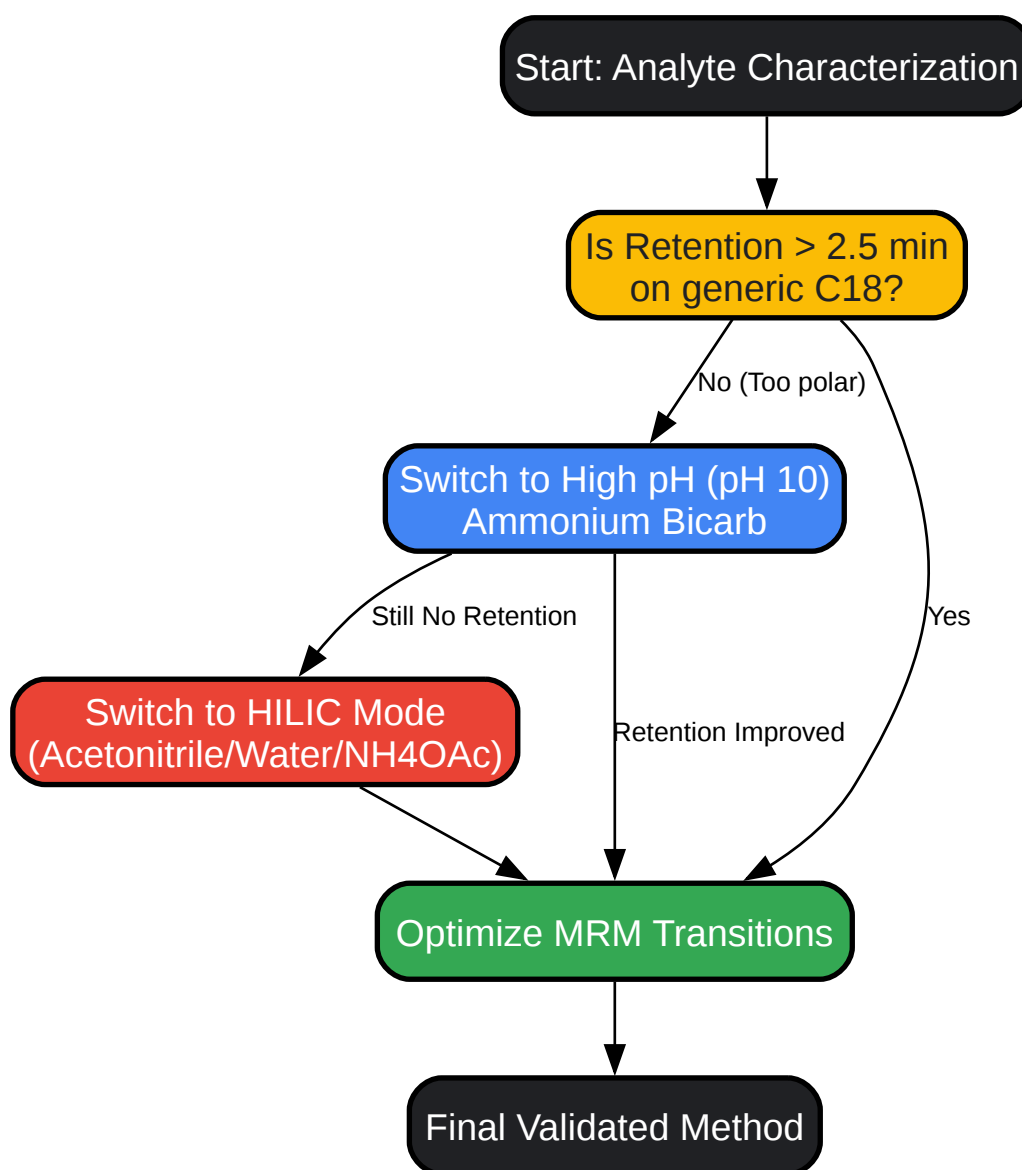

[Click to download full resolution via product page](#)

Caption: Figure 2. Decision logic for LC-MS method development, prioritizing Reverse Phase pH modification before switching to HILIC.

## References

- Frizzo, C. P., et al. (2013). Trends for Pyrazole Fragmentation Determined by Gas Chromatography Coupled with Mass Spectrometry. In Gas Chromatography - Aspects of Theory and Practice. IntechOpen.[3] [Link](#)
- Holčapek, M., et al. (2010). Mass spectrometry of nitrogen-containing heterocycles. Journal of Chromatography A, 1217(25), 3908-3921. [Link](#)
- McLafferty, F. W., & Tureček, F. (1993). Interpretation of Mass Spectra. University Science Books. (Standard text for Alpha-cleavage rules).
- NIST Chemistry WebBook. Mass Spectrum of 1-Methylpyrazole (Analog Reference). National Institute of Standards and Technology.[4] [Link](#)

### *Need Custom Synthesis?*

*BenchChem offers custom synthesis for rare earth carbides and specific isotopic labeling.*

*Email: [info@benchchem.com](mailto:info@benchchem.com) or [Request Quote Online](#).*

## Sources

- 1. [chemscene.com](https://chemscene.com) [[chemscene.com](https://chemscene.com)]
- 2. [spectrabase.com](https://spectrabase.com) [[spectrabase.com](https://spectrabase.com)]
- 3. [youtube.com](https://youtube.com) [[youtube.com](https://youtube.com)]
- 4. 1H-Pyrazole, 1-methyl- [[webbook.nist.gov](https://webbook.nist.gov)]
- To cite this document: BenchChem. [Comprehensive Technical Guide: Mass Spectrometry of 4-(1-methoxyethyl)-1H-pyrazole]. BenchChem, [2026]. [Online PDF]. Available at: [<https://www.benchchem.com/product/b13559992/docs#comprehensive-technical-guide-mass-spectrometry-of-4-1-methoxyethyl-1h-pyrazole>]

**Disclaimer & Data Validity:**

The information provided in this document is for Research Use Only (RUO) and is strictly not intended for diagnostic or therapeutic procedures. While BenchChem strives to provide accurate protocols, we make no warranties, express or implied, regarding the fitness of this product for every specific experimental setup.

**Technical Support:** The protocols provided are for reference purposes. Unsure if this reagent suits your experiment?

**Need Industrial/Bulk Grade?** [Request Custom Synthesis Quote](#)

## BenchChem

Our mission is to be the trusted global source of essential and advanced chemicals, empowering scientists and researchers to drive progress in science and industry.

### Contact

Address: 3281 E Guasti Rd  
Ontario, CA 91761, United States  
Phone: (601) 213-4426  
Email: [info@benchchem.com](mailto:info@benchchem.com)

[Contact our Ph.D. Support Team for a compatibility check](#)