

Application Notes & Protocols: Strategic Conversion of β -Hydroxy Esters to Cyclopropyl Amines

Author: BenchChem Technical Support Team. **Date:** April 2026

Compound of Interest

Compound Name: *Methyl 3-(3,4-difluorophenyl)-3-hydroxypropanoate*

Cat. No.: *B13557219*

[Get Quote](#)

Introduction: The Strategic Value of Cyclopropyl Amines from β -Hydroxy Esters

In the landscape of modern medicinal chemistry, the cyclopropylamine motif stands out as a "privileged" scaffold. Its inherent three-membered ring introduces a unique conformational rigidity and a specific steric profile that can significantly enhance the pharmacological properties of drug candidates, including binding affinity, metabolic stability, and cell permeability.[1][2] Compounds incorporating this moiety are found in various therapeutic agents, acting as inhibitors for enzymes like Lysine-Specific Demethylase 1 (LSD1) and Monoamine Oxidase (MAO).[1]

β -Hydroxy esters serve as ideal starting materials for the synthesis of these valuable molecules. They are readily accessible, often through well-established asymmetric synthesis routes like aldol reactions or the enantioselective reduction of β -keto esters, providing a gateway to optically pure final products.[3][4][5] This guide details the primary synthetic strategies for the multi-step conversion of β -hydroxy esters to cyclopropyl amines, focusing on

the underlying chemical principles, providing field-tested protocols, and offering guidance for method selection.

Primary Synthetic Pathway: A Three-Act Synthesis

The most robust and widely applicable strategy for converting β -hydroxy esters to cyclopropyl amines is a three-stage process: dehydration to an α,β -unsaturated ester, cyclopropanation of the alkene, and finally, functional group transformation of the ester to the target amine. This sequence leverages well-understood, high-yielding reactions to construct the desired scaffold.

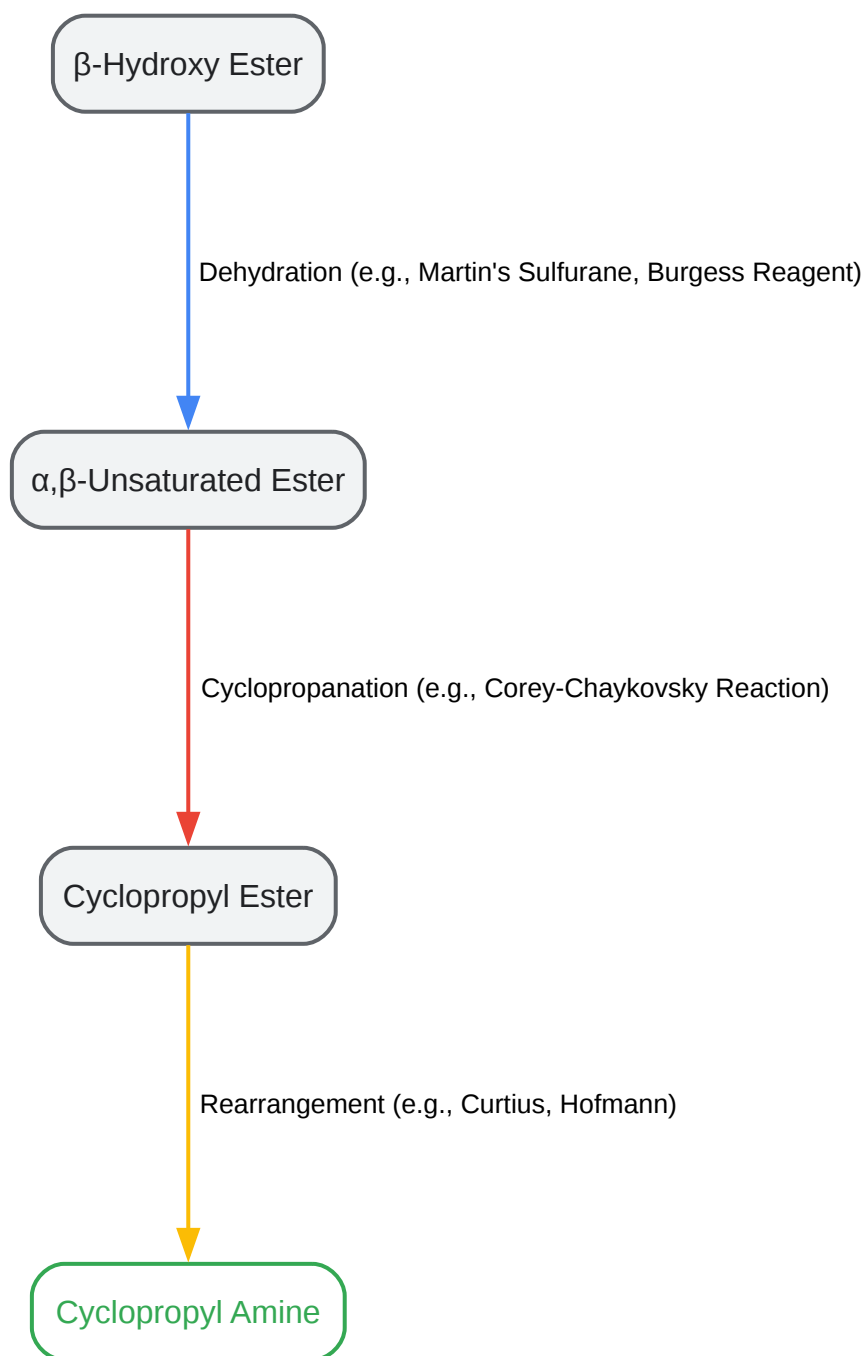

[Click to download full resolution via product page](#)

Caption: Overall workflow for the conversion of β-hydroxy esters to cyclopropyl amines.

Act I: Dehydration to α,β-Unsaturated Esters

The initial step involves the elimination of water to form an electronically poor alkene, which is an ideal substrate for subsequent nucleophilic cyclopropanation. The choice of dehydration

agent is critical to control selectivity (E vs. Z isomers) and avoid side reactions.

- Mechanism & Rationale: Reagents like Martin's sulfurane or the Burgess reagent are often preferred over simple acid catalysis as they operate under milder conditions, minimizing the risk of ester hydrolysis or other acid-catalyzed side reactions. These methods proceed through concerted syn-elimination or anti-elimination pathways, offering predictable stereochemical outcomes based on the substrate conformation.

Act II: Methylene Transfer via Johnson-Corey-Chaykovsky Reaction

With the α,β -unsaturated ester in hand, the next stage is the formation of the cyclopropane ring. The Johnson-Corey-Chaykovsky reaction is exceptionally well-suited for this transformation.^[6] It involves the reaction of a sulfur ylide with an electron-deficient alkene, such as a Michael acceptor.^{[7][8]}

- Mechanism & Rationale: The reaction is initiated by the 1,4-conjugate addition of the sulfur ylide to the α,β -unsaturated ester.^[9] This is followed by an intramolecular nucleophilic substitution, where the resulting enolate attacks the carbon bearing the sulfonium leaving group, leading to ring closure and formation of the trans-cyclopropane product, which is typically the thermodynamically favored isomer.^[10] Dimethylsulfoxonium methylide (Corey's ylide) is often used for this purpose.^{[9][10]}

Act III: Ester to Amine Conversion via Curtius Rearrangement

The final stage requires the conversion of the stable ester group into a primary amine. While several methods exist, the Curtius rearrangement offers a reliable and high-yielding pathway, particularly when starting from the corresponding carboxylic acid (obtained via saponification of the ester).^{[2][11]}

- Mechanism & Rationale: The Curtius rearrangement proceeds through the thermal or photochemical decomposition of an acyl azide. The acyl azide is typically generated from a carboxylic acid derivative (like an acid chloride) or by reacting an acyl hydrazide with nitrous acid. Upon heating, the acyl azide loses dinitrogen gas to form a highly reactive acyl nitrene

intermediate, which rearranges to an isocyanate.[2] This isocyanate can then be hydrolyzed with aqueous acid or base to yield the primary amine and carbon dioxide.

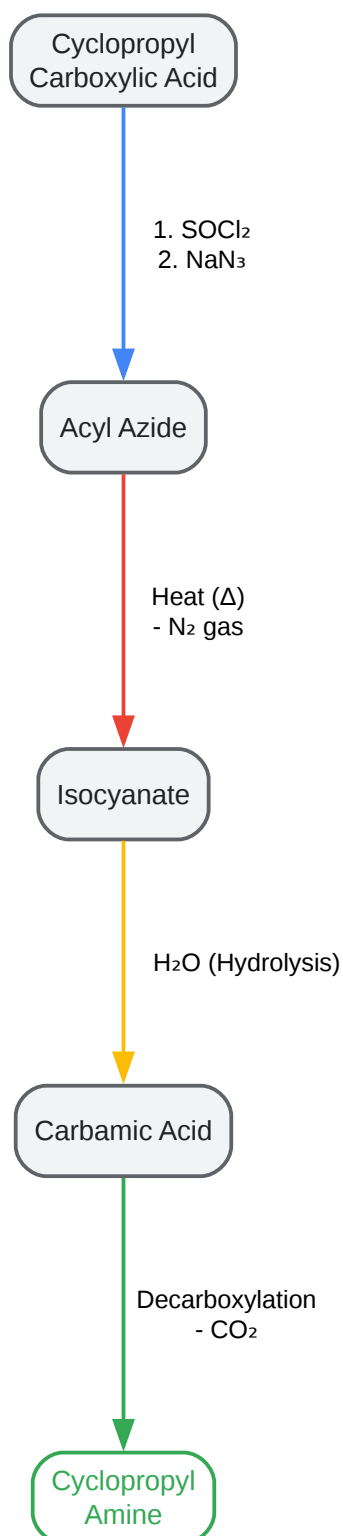

[Click to download full resolution via product page](#)

Caption: Key stages of the Curtius Rearrangement for amine synthesis.

Detailed Experimental Protocols

The following protocols are based on a model system converting a generic β -hydroxy ester to a cyclopropyl amine. Safety Precaution: Always work in a well-ventilated fume hood and wear appropriate personal protective equipment (PPE), including safety glasses, lab coat, and gloves. Operations involving sodium hydride, azides, and isocyanates require extreme caution.

Protocol 2.1: Corey-Chaykovsky Cyclopropanation of an α,β -Unsaturated Ester

This protocol details the formation of a cyclopropyl ester from an alkene using Corey's ylide.

Materials:

- Trimethylsulfoxonium iodide (2.42 g, 11.0 mmol, 1.1 equiv)
- Sodium hydride (NaH), 60% dispersion in mineral oil (440 mg, 11.0 mmol, 1.1 equiv)
- Anhydrous Dimethyl Sulfoxide (DMSO) (20 mL)
- α,β -Unsaturated Ester (10.0 mmol, 1.0 equiv)
- Anhydrous Tetrahydrofuran (THF) (20 mL)
- Saturated aqueous ammonium chloride (NH_4Cl) solution
- Diethyl ether
- Brine
- Anhydrous magnesium sulfate (MgSO_4)

Procedure:

- To an oven-dried, three-neck round-bottom flask equipped with a magnetic stirrer, nitrogen inlet, and thermometer, add trimethylsulfoxonium iodide.

- Under a nitrogen atmosphere, add anhydrous DMSO. Stir until the solid is partially dissolved.
- Carefully add the sodium hydride dispersion portion-wise over 15 minutes. Caution: Hydrogen gas is evolved. Ensure adequate ventilation.
- Stir the resulting milky white suspension at room temperature for 45-60 minutes, until gas evolution ceases. The sulfur ylide has now been formed in situ.[\[10\]](#)
- In a separate flask, dissolve the α,β -unsaturated ester in anhydrous THF.
- Cool the ylide suspension to 10-15 °C using a water bath.
- Add the solution of the α,β -unsaturated ester dropwise to the ylide suspension over 30 minutes, maintaining the internal temperature below 25 °C.
- After the addition is complete, allow the reaction to stir at room temperature for 3-5 hours, or until TLC analysis indicates complete consumption of the starting material.
- Carefully quench the reaction by slowly adding it to an ice-cold saturated aqueous solution of NH_4Cl (50 mL).
- Extract the aqueous mixture with diethyl ether (3 x 40 mL).
- Combine the organic layers, wash with water (2 x 30 mL) and then with brine (30 mL).
- Dry the organic phase over anhydrous MgSO_4 , filter, and concentrate under reduced pressure.
- Purify the crude product by silica gel column chromatography to yield the desired cyclopropyl ester.

Protocol 2.2: Saponification and Curtius Rearrangement

This protocol covers the conversion of the cyclopropyl ester to the final amine product. Safety Precaution: This procedure involves the formation of a potentially explosive acyl azide and a toxic isocyanate. Perform behind a blast shield in a fume hood. Avoid using metal spatulas with azides.

Materials:

- Cyclopropyl Ester (5.0 mmol, 1.0 equiv)
- Ethanol (15 mL)
- 1 M Sodium Hydroxide (NaOH) solution (10 mL, 10 mmol, 2.0 equiv)
- 1 M Hydrochloric Acid (HCl)
- Oxalyl chloride or Thionyl chloride (SOCl₂) (0.5 mL, ~1.4 equiv)
- Anhydrous Dichloromethane (DCM) or Toluene (15 mL)
- N,N-Dimethylformamide (DMF) (1-2 drops, catalytic)
- Sodium azide (NaN₃) (488 mg, 7.5 mmol, 1.5 equiv)
- tert-Butanol (10 mL)
- Concentrated HCl

Procedure:

Part A: Saponification to the Carboxylic Acid

- Dissolve the cyclopropyl ester in ethanol in a round-bottom flask.
- Add the 1 M NaOH solution and stir the mixture at 50 °C for 2-4 hours, monitoring by TLC until the starting ester is consumed.
- Cool the mixture to room temperature and remove the ethanol under reduced pressure.
- Add water (20 mL) and wash with diethyl ether (2 x 15 mL) to remove any unreacted ester.
- Cool the aqueous layer in an ice bath and acidify to pH ~2 with 1 M HCl.
- Extract the cyclopropyl carboxylic acid with DCM (3 x 20 mL).

- Combine the organic layers, dry over anhydrous MgSO_4 , filter, and concentrate to yield the crude acid, which is often used directly in the next step.

Part B: Curtius Rearrangement

- Dissolve the crude cyclopropyl carboxylic acid in anhydrous DCM or toluene. Add a catalytic amount of DMF.
- Cool the solution in an ice bath and slowly add oxalyl chloride or SOCl_2 . Stir for 1-2 hours at room temperature until gas evolution stops.
- Remove the solvent and excess reagent under reduced pressure to obtain the crude acyl chloride.
- [CAUTION] In a separate flask, dissolve sodium azide in a minimal amount of water and add acetone. Cool in an ice bath.
- Dissolve the crude acyl chloride in acetone and add it dropwise to the sodium azide solution. Stir vigorously at $0\text{ }^\circ\text{C}$ for 1 hour.
- Quench with ice-water and extract the acyl azide with toluene. [CAUTION: Acyl azides are explosive; do not concentrate to dryness].
- Carefully separate the organic layer, dry it briefly over anhydrous Na_2SO_4 , and transfer it to a flask containing tert-butanol.
- Heat the solution gently to $80\text{-}90\text{ }^\circ\text{C}$. Vigorous nitrogen evolution will occur as the azide rearranges to the isocyanate, which is then trapped by tert-butanol to form a Boc-protected amine.
- Once gas evolution ceases (1-3 hours), cool the reaction and remove the solvent under reduced pressure.
- To the crude Boc-protected amine, add a solution of concentrated HCl in methanol or dioxane and stir at room temperature for 2-4 hours to cleave the Boc group.

- Concentrate the mixture under reduced pressure, and partition the residue between dilute NaOH and diethyl ether to isolate the free cyclopropyl amine.

Method Selection and Comparative Analysis

The choice of reagents and reaction pathways depends on the specific substrate, available equipment, and safety considerations.

Parameter	Corey-Chaykovsky	Simmons-Smith
Substrate	Ideal for electron-poor alkenes (e.g., α,β -unsaturated esters). [8]	Broad applicability, including unactivated alkenes.
Reagents	Sulfur ylide (from sulfonium/sulfoxonium salt + strong base).[9]	Carbenoid (from diiodomethane + Zn-Cu couple).[12]
Stereocontrol	Generally gives trans product with acyclic enones.[10]	Stereospecific (syn-addition); directed by hydroxyl groups. [12]
Safety	Requires handling of strong bases (e.g., NaH).	Diiodomethane is a toxic alkylating agent.

Table 1: Comparison of Common Cyclopropanation Methods.

Parameter	Curtius Rearrangement	Hofmann Rearrangement
Precursor	Carboxylic Acid → Acyl Azide. [2]	Primary Amide.[13]
Key Intermediate	Isocyanate.	Isocyanate.
Reagents	Sodium azide, acid chloride formation.	Bromine or NBS, strong base (NaOH).
Scope	Very broad and generally high-yielding.	Tolerates many functional groups, but can be lower yielding.
Safety	HIGH RISK: Involves potentially explosive acyl azides.[2]	Involves handling of bromine and strong base.

Table 2: Comparison of Ester-to-Amine Conversion Methods.

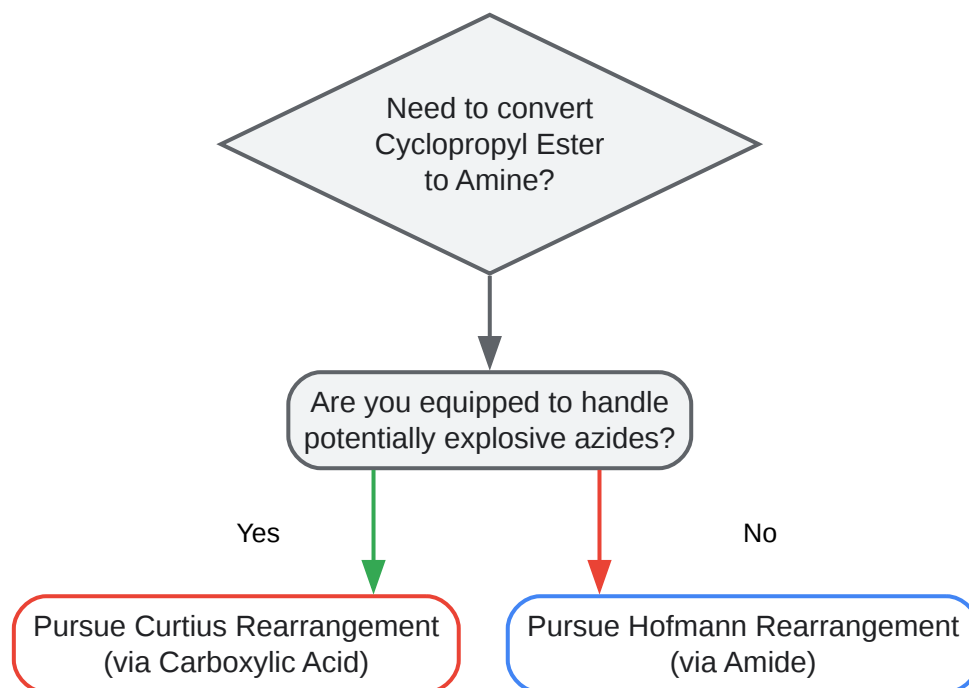

[Click to download full resolution via product page](#)

Need Custom Synthesis?

BenchChem offers custom synthesis for rare earth carbides and specific isotopic labeling.

Email: info@benchchem.com or [Request Quote Online](#).

Sources

- [1. pdf.benchchem.com \[pdf.benchchem.com\]](https://pdf.benchchem.com)
- [2. pubs.acs.org \[pubs.acs.org\]](https://pubs.acs.org)
- [3. mdpi.com \[mdpi.com\]](https://mdpi.com)
- [4. \$\beta\$ -Hydroxy carboxylic compound synthesis by addition \(C-C coupling\) \[organic-chemistry.org\]](https://organic-chemistry.org)
- [5. researchgate.net \[researchgate.net\]](https://researchgate.net)
- [6. A review on the sulfur ylide-mediated Corey–Chaykovsky reaction: a powerful approach to natural product synthesis - RSC Advances \(RSC Publishing\) DOI:10.1039/D5RA04921K \[pubs.rsc.org\]](https://pubs.rsc.org)
- [7. Johnson–Corey–Chaykovsky reaction - Wikipedia \[en.wikipedia.org\]](https://en.wikipedia.org)
- [8. Cyclopropanation - Wikipedia \[en.wikipedia.org\]](https://en.wikipedia.org)
- [9. Corey-Chaykovsky Reaction \[organic-chemistry.org\]](https://organic-chemistry.org)
- [10. adichemistry.com \[adichemistry.com\]](https://adichemistry.com)
- [11. researchgate.net \[researchgate.net\]](https://researchgate.net)
- [12. pubs.acs.org \[pubs.acs.org\]](https://pubs.acs.org)
- [13. US3711549A - Process for manufacturing cyclopropylamine - Google Patents \[patents.google.com\]](https://patents.google.com)
- To cite this document: BenchChem. [Application Notes & Protocols: Strategic Conversion of β -Hydroxy Esters to Cyclopropyl Amines]. BenchChem, [2026]. [Online PDF]. Available at: [\[https://www.benchchem.com/product/b13557219/docs#application-notes-protocols-strategic-conversion-of-hydroxy-esters-to-cyclopropyl-amines\]](https://www.benchchem.com/product/b13557219/docs#application-notes-protocols-strategic-conversion-of-hydroxy-esters-to-cyclopropyl-amines)

Disclaimer & Data Validity:

The information provided in this document is for Research Use Only (RUO) and is strictly not intended for diagnostic or therapeutic procedures. While BenchChem strives to provide accurate protocols, we make no warranties, express or implied, regarding the fitness of this product for every specific experimental setup.

Technical Support: The protocols provided are for reference purposes. Unsure if this reagent suits your experiment?

Need Industrial/Bulk Grade? [Request Custom Synthesis Quote](#)

BenchChem

Our mission is to be the trusted global source of essential and advanced chemicals, empowering scientists and researchers to drive progress in science and industry.

Contact

Address: 3281 E Guasti Rd
Ontario, CA 91761, United States
Phone: (601) 213-4426
Email: info@benchchem.com

[Contact our Ph.D. Support Team for a compatibility check](#)