

Technical Support Center: Chiral Amino Alcohol Purification

Author: BenchChem Technical Support Team. **Date:** April 2026

Compound of Interest

Compound Name: 2-Amino-2-methyl-pentan-3-OL

CAS No.: 89585-20-6

Cat. No.: B13553977

[Get Quote](#)

Status: Online Operator: Senior Application Scientist Topic: Troubleshooting Purification of Chiral Amino Alcohols Ticket ID: #CAA-PUR-2024

Welcome to the Purification Support Hub

Chiral amino alcohols (e.g.,

-blockers, norephedrine derivatives) represent a "perfect storm" of purification challenges: they are polar, basic, and often lack strong chromophores. This guide addresses the three most common support tickets we receive: chromatographic peak tailing, method development failure, and scale-up crystallization issues.

Module 1: Chromatography Support (HPLC/SFC)

Current Issue: Severe peak tailing and poor resolution on silica-based chiral columns.

Root Cause Analysis

Amino alcohols possess a basic nitrogen atom and a hydroxyl group. The primary cause of tailing is the Silanol Effect. Residual silanol groups (

) on the silica support of chiral columns act as weak acids. They protonate the basic amine of your analyte, causing secondary ion-exchange interactions that drag the peak (tailing) and destroy resolution.

Troubleshooting Protocol: The "Silanol Block" Strategy

Step 1: Mobile Phase Additives (The First Line of Defense) Do not run neutral mobile phases. You must suppress ionization or block silanols.

Additive Type	Recommended Reagent	Concentration	Mechanism
Basic (Standard)	Diethylamine (DEA)	0.1% v/v	Competes for silanol sites; suppresses amine protonation.
Basic (Alternative)	Triethylamine (TEA)	0.1% v/v	Stronger blocker, but higher UV cutoff (use >254 nm).
Basic (Volatile)	Isopropylamine	0.1% - 0.5%	Best for Prep-LC/SFC; easy to remove during evaporation.
Acidic/Basic Mix	TFA (0.1%) + DEA (0.1%)	1:1 Ratio	Creates a buffered environment; useful for zwitterionic species.

Step 2: Column Selection (Immobilized vs. Coated) If additives fail, your solvent might be the issue. Amino alcohols often require polar solvents (MeOH, DCM) for solubility, which can strip coated polysaccharide phases (e.g., Chiralpak AD/OD).

- Recommendation: Switch to Immobilized phases (e.g., Chiralpak IA, IB, IC, IG).
- Why: The chiral selector is chemically bonded to the silica, allowing the use of "forbidden" solvents like Dichloromethane (DCM) or THF, which solubilize amino alcohols better and reduce aggregation.

Decision Logic: Peak Tailing

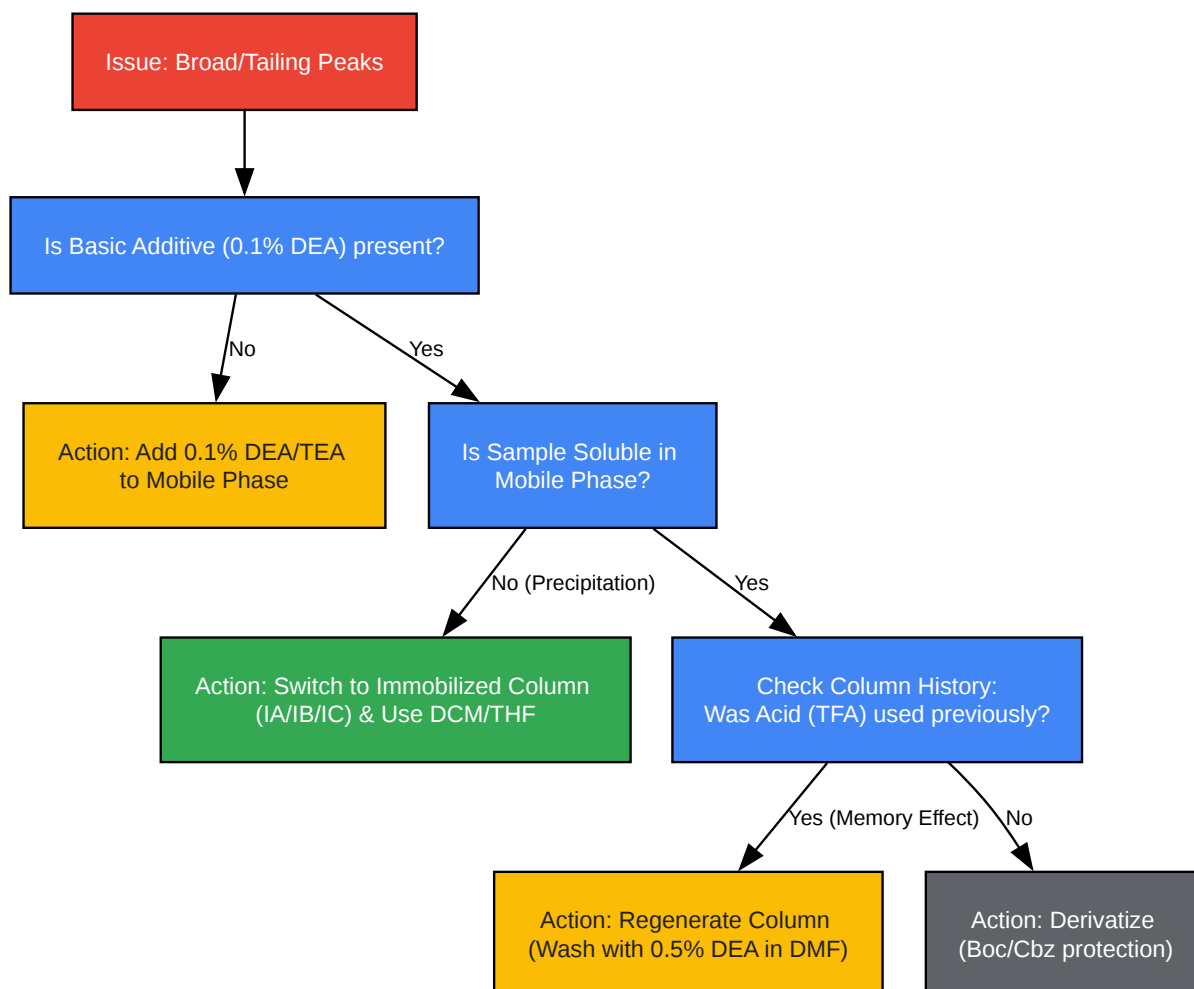

[Click to download full resolution via product page](#)

Caption: Logic flow for diagnosing and resolving peak tailing in chiral amino alcohol chromatography.

Module 2: Method Development (SFC Focus)

Current Issue: HPLC pressure is too high, and run times are too long for preparative scale.

Insight: Chiral amino alcohols are ideal candidates for Supercritical Fluid Chromatography (SFC). The low viscosity of supercritical

allows for high flow rates, and the high diffusivity improves mass transfer for these polar molecules.

SFC Screening Protocol

- Gradient Screening:
 - Mobile Phase A:
 - Mobile Phase B: Methanol + 0.2% Isopropylamine (IPA-amine is preferred over DEA in SFC to prevent carbamate salt formation with).
 - Gradient: 5% to 50% B over 5 minutes.
 - Back Pressure: 120-150 bar.
- Column Hierarchy:
 - Primary: Chiralpak IG or IC (Immobilized, broad selectivity for amines).
 - Secondary: Chiralcel OD-H (Coated, classic "workhorse" for -blockers).
 - Tertiary: Chiralpak AD-H (Amylose based).
- The "Fog" Effect (Self-Validation):
 - Observation: Baseline noise or "fog" at the detector.
 - Cause: Phase separation of the additive.
 - Fix: Ensure the make-up solvent (for UV/MS) matches the modifier composition.

Module 3: Crystallization & Scale-Up

Current Issue: Reaction formed an oil instead of crystals during diastereomeric salt resolution.

The "Dutch Resolution" Strategy

Classical resolution often fails because the diastereomeric salt is too soluble or forms a supersaturated oil (oiling out). The Dutch Resolution method (developed by nucleation experts) suggests using a family of resolving agents rather than a single one.

Why it works: Impurities (including the unwanted enantiomer) inhibit crystal growth. Using a mix of structurally related resolving agents (e.g., distinct tartaric acid derivatives) disrupts the inhibition network, allowing the pure salt to nucleate.

Protocol: Diastereomeric Salt Resolution

- Stoichiometry: Use 0.5 to 1.0 equivalents of the Resolving Agent (RA).
- Solvent: Ethanol/Water (9:1) or Isopropanol.^{[1][2]}
- Procedure:
 - Dissolve Racemic Amino Alcohol (1 eq) in hot solvent.
 - Add Resolving Agent (e.g., Dibenzoyl-L-tartaric acid).
 - Critical Step: If oiling occurs, seed with crystals from a small-scale trial or scratch the glass.
 - Advanced: If no crystals form, use a 1:1:1 mix of Dibenzoyl-tartaric, Di-p-toluyl-tartaric, and Di-p-anisoyl-tartaric acids (The "Family" approach). The solid that precipitates will usually contain one specific salt in high purity.

Workflow: The RRR Cycle

To make the process economical, you must recycle the unwanted isomer.

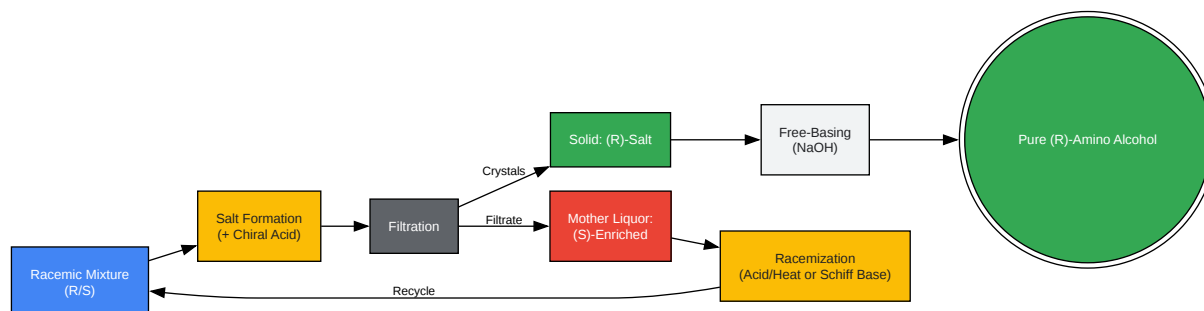

[Click to download full resolution via product page](#)

Caption: RRR (Resolution-Racemization-Recycle) workflow for maximizing yield in chiral production.

Module 4: Detection & Visibility

Current Issue: My amino alcohol has no UV absorbance (e.g., aliphatic amino alcohols).

Solution: Derivatization.^{[2][3][4][5][6]} Direct chiral HPLC requires a chromophore. If your molecule is aliphatic (e.g., leucinol), you cannot see it at standard UV (254 nm).

Protocol: Fast Derivatization for HPLC

- Reagent: 3,5-Dinitrobenzoyl chloride (DNB-Cl) or FDNB (Sanger's reagent).
- Reaction: Mix analyte + Reagent +

in THF/Water (1:1). Stir 30 mins at RT.
- Benefit: Introduces a "pi-acidic" group that not only allows UV detection (254 nm) but enhances separation on "pi-basic" columns (like Chiralpak AD/IA) via interactions.

References

- Daicel Chiral Technologies. (2021). Instruction Manual for Immobilized CHIRALPAK® IA, IB, IC, ID, IE, IF, IG, IH, IJ, IK, IM, IN, IQ.[Link](#)
- Vries, T. D., et al. (1998). "The Family Approach to the Resolution of Racemates." *Angewandte Chemie International Edition*, 37(17), 2349-2354. [Link](#)
- BenchChem. (2025).^[1]^[5] Technical Support Center: Chiral Separation of Amino Alcohol Enantiomers.[Link](#)
- Chromatography Today. (2020). Trouble with Chiral Separations: Additive Memory Effects. ^[7][Link](#)
- Unchained Labs. (2019). Identifying a diastereomeric salt for a challenging chiral resolution.[Link](#)

Need Custom Synthesis?

BenchChem offers custom synthesis for rare earth carbides and specific isotopic labeling.

Email: info@benchchem.com or [Request Quote Online](#).

Sources

- 1. pdf.benchchem.com [pdf.benchchem.com]
- 2. erowid.org [erowid.org]
- 3. Chiral separation on various modified amino alcohol-derived HPLC chiral stationary phases - PubMed [pubmed.ncbi.nlm.nih.gov]
- 4. Chiral resolution - Wikipedia [en.wikipedia.org]
- 5. pdf.benchchem.com [pdf.benchchem.com]
- 6. Enantiomeric separation of alcohols and amines on a proline chiral stationary phase by gas chromatography - PMC [pmc.ncbi.nlm.nih.gov]
- 7. chromatographytoday.com [chromatographytoday.com]
- To cite this document: BenchChem. [Technical Support Center: Chiral Amino Alcohol Purification]. BenchChem, [2026]. [Online PDF]. Available at:

[\[https://www.benchchem.com/product/b13553977/docs#technical-support-center-chiral-amino-alcohol-purification\]](https://www.benchchem.com/product/b13553977/docs#technical-support-center-chiral-amino-alcohol-purification)

Disclaimer & Data Validity:

The information provided in this document is for Research Use Only (RUO) and is strictly not intended for diagnostic or therapeutic procedures. While BenchChem strives to provide accurate protocols, we make no warranties, express or implied, regarding the fitness of this product for every specific experimental setup.

Technical Support: The protocols provided are for reference purposes. Unsure if this reagent suits your experiment?

Need Industrial/Bulk Grade? [Request Custom Synthesis Quote](#)

BenchChem

Our mission is to be the trusted global source of essential and advanced chemicals, empowering scientists and researchers to drive progress in science and industry.

Contact

Address: 3281 E Guasti Rd
Ontario, CA 91761, United States
Phone: (601) 213-4426
Email: info@benchchem.com

[Contact our Ph.D. Support Team for a compatibility check](#)