

Application Note: Microwave-Assisted Synthesis & Functionalization of Indazole-3-Carboxylic Acids

Author: BenchChem Technical Support Team. **Date:** May 2026

Compound of Interest

Compound Name:	3-(Hydroxymethyl)-1H-indazole-5-carboxylic acid
CAS No.:	1082041-77-7
Cat. No.:	B13543210

[Get Quote](#)

Executive Summary

Indazole-3-carboxylic acid and its derivatives represent a privileged scaffold in medicinal chemistry, serving as the core structure for anti-tumor agents (e.g., Lonidamine), anti-emetics (e.g., Granisetron), and varying kinase inhibitors. Conventional thermal synthesis of these motifs often suffers from prolonged reaction times (12–24 hours), harsh reagents (e.g., strong acids for cyclization), and difficult purification steps.

This guide details microwave-assisted organic synthesis (MAOS) protocols that reduce reaction times to minutes while improving yield and purity. We focus on two critical workflows:

- Green Synthesis of the Indazole Core: A water-based, catalyst-free cyclization protocol.
- Rapid Functionalization: A direct amidation protocol for Indazole-3-carboxylic acid to generate libraries of bioactive carboxamides (Lonidamine analogues).

Mechanistic Insight: Why Microwave?

The efficiency of these protocols relies on dielectric heating, specifically acting on the polar indazole precursors.^[1]

- **Dipolar Polarization:** The polar N-H and C=O bonds in indazole precursors align with the oscillating electric field. At 2.45 GHz, this molecular rotation generates internal heat, overcoming the activation energy () barrier for cyclization more efficiently than conductive heating.
- **The "Superheating" Effect:** In sealed vessels, solvents like water or ethanol can be heated well above their atmospheric boiling points. For the indazole cyclization (Protocol 1), water at 160°C acts as a pseudo-organic solvent with lowered dielectric constant (), dissolving organic reactants that are insoluble at 100°C.

Protocol 1: Aqueous, One-Pot Synthesis of the Indazole Scaffold

Target: Rapid construction of 1H-indazole core from 2-halobenzaldehydes.

This method utilizes water as a green solvent, leveraging the high microwave absorptivity of water (

at 25°C, increasing with temperature) to drive the reaction.

Reagents & Materials

- Substrate: 2-Chloro- or 2-Fluorobenzaldehyde (1.0 mmol)
- Reagent: Hydrazine Hydrate (2.0 mmol)^[1]
- Solvent: Distilled Water (10 mL)
- Additives: None (Catalyst-free) or CuO nanoparticles (optional for lower temp)
- Equipment: Single-mode Microwave Reactor (e.g., Anton Paar Monowave or CEM Discover)

Step-by-Step Methodology

- Preparation: In a 30 mL microwave process vial, charge the 2-halobenzaldehyde and hydrazine hydrate. Add distilled water.
- Sealing: Cap the vial with a PTFE/silicone septum.
- Irradiation:
 - Phase 1 (Hydrazone formation): Heat to 100°C for 2 minutes (dynamic power mode).
 - Phase 2 (Cyclization): Ramp temperature to 160°C and hold for 10–15 minutes.
 - Note: The internal pressure will rise to ~5–6 bar. Ensure the vessel is rated for 20 bar.
- Workup: Cool to 50°C using compressed air. The product typically precipitates as a solid.
- Isolation: Filter the solid, wash with cold water (3 x 10 mL) to remove excess hydrazine, and recrystallize from ethanol if necessary.

Reaction Scheme Visualization

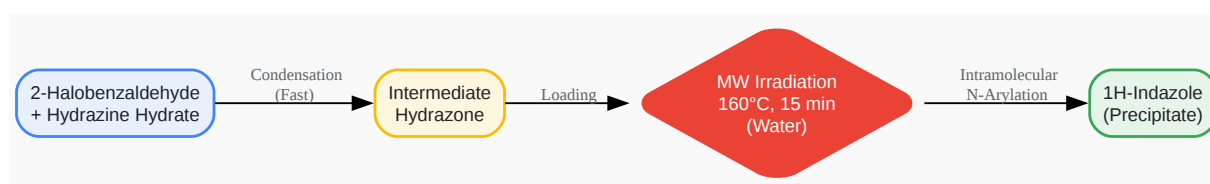

[Click to download full resolution via product page](#)

Figure 1: One-pot aqueous synthesis workflow for the Indazole core.

Protocol 2: Direct Amidation of Indazole-3-Carboxylic Acid

Target: Synthesis of Lonidamine Analogues (Indazole-3-carboxamides).

Functionalizing the C3-carboxylic acid position is the primary route to bioactive analogues. Conventional methods require converting the acid to an acid chloride (using

), which is moisture-sensitive and incompatible with diverse amines. This microwave protocol uses a coupling agent or catalyst for direct amidation.

Reagents & Materials

- Substrate: 1H-Indazole-3-carboxylic acid (1.0 mmol)
- Amine: Substituted aniline (e.g., 2,4-dichloroaniline) or aliphatic amine (1.1 mmol)
- Coupling Agent: T3P (Propylphosphonic anhydride, 50% in EtOAc) OR catalytic CAN (Ceric Ammonium Nitrate, 10 mol%).
- Base: Pyridine or Triethylamine (2.0 mmol)
- Solvent: Ethyl Acetate (EtOAc) or Acetonitrile.

Step-by-Step Methodology

- Activation: In a 10 mL microwave vial, dissolve Indazole-3-carboxylic acid and the Base in EtOAc (3 mL). Stir for 1 minute.
- Addition: Add the Amine followed by T3P solution (1.5 mmol).
- Irradiation:
 - Temperature: 80°C (for aliphatic amines) or 100°C (for anilines).
 - Time: 10–20 minutes.
 - Power: Max 150 W (Dynamic).
- Workup:
 - Dilute reaction mixture with EtOAc (20 mL).
 - Wash with 1N HCl (to remove excess amine/pyridine).

- Wash with sat.[2]

(to remove unreacted acid).
- Dry organic layer over

and evaporate.
- Validation: Check purity via HPLC. Yields typically exceed 85%.[1][3][4]

Workflow Visualization

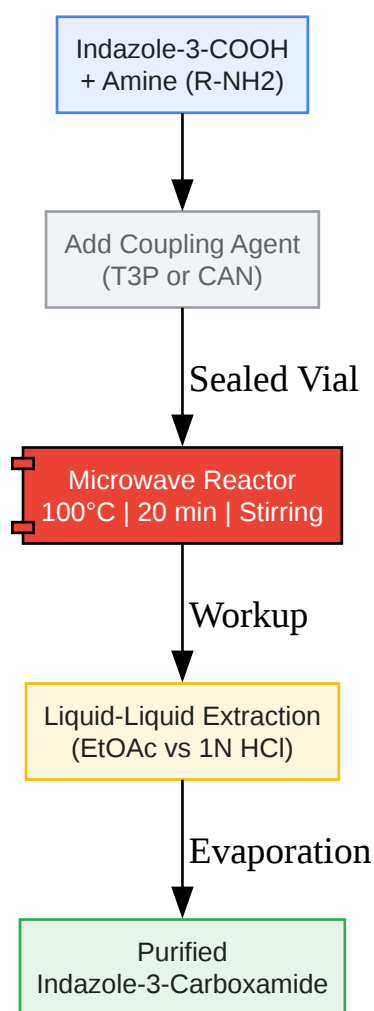

[Click to download full resolution via product page](#)

Figure 2: High-throughput amidation workflow for generating Indazole-3-carboxylic acid libraries.

Data Analysis: Microwave vs. Conventional[1][5][6][7]

The following table summarizes the efficiency gains observed when applying Protocol 1 (Core Synthesis) and Protocol 2 (Amidation) compared to traditional thermal methods (oil bath reflux).

Reaction Type	Method	Temperature	Time	Yield (%)	Solvent
Indazole Core	Conventional	Reflux (100°C)	12–16 hrs	55–65%	Water/EtOH
	Microwave	160°C	15 min	85–92%	Water
Amidation	Conventional	Reflux ()	4–6 hrs	60–75%	Toluene/DCM
	Microwave	100°C	20 min	88–95%	EtOAc

Data aggregated from comparative studies in green heterocyclic synthesis.

Optimization & Troubleshooting

Solvent Selection (Tan)

- Water: Excellent absorber. Use for Protocol 1. If the substrate is highly lipophilic, add 10% Ethanol or use "Microwave-absorbing" passive heating elements (SiC vials) if available.
- Ethyl Acetate: Weak absorber. For Protocol 2, ensure the reaction volume is sufficient (min 2 mL) or add a "spike" of ionic liquid or polar solvent (e.g., 0.5 mL DMF) to initiate heating if the reactor struggles to reach 100°C.

Safety Considerations

- Pressure: Heating water to 160°C generates ~6 bar of pressure. Do not use standard glassware; use certified borosilicate or quartz microwave vials with pressure-release caps.

- Hydrazine: Hydrazine hydrate is toxic and potentially unstable. The microwave method minimizes exposure time, but all loading should occur in a fume hood.

References

- Microwave Assisted Greener Synthesis of Indazoles via one pot two step Cyclization of Hydrazone Hydrate. Asian Journal of Research in Chemistry. [\[Link\]](#)
- Microwave-Assisted Catalytic Method for a Green Synthesis of Amides Directly from Amines and Carboxylic Acids. Molecules (MDPI). [\[Link\]](#)
- Process for the preparation of 1H-indazole-3-carboxylic acid derivatives.
- Microwave Assisted Synthesis and Biological Evaluation of Indazole Derivatives. Journal of Chemical Health Risks. [\[Link\]](#)
- Method for synthesis of Ionidamine and related indazole derivatives.

Need Custom Synthesis?

BenchChem offers custom synthesis for rare earth carbides and specific isotopic labeling.

Email: info@benchchem.com or [Request Quote Online](#).

Sources

- 1. jchr.org [jchr.org]
- 2. WO2005120498A2 - Method for synthesis of Ionidamine and related indazole derivatives - Google Patents [patents.google.com]
- 3. US20110172428A1 - Methods for the preparation of indazole-3-carboxylic acid and n-(s)-1-azabicyclo[2.2.2]oct-3-yl-1h-indazole-3-carboxamide hydrochloride salt - Google Patents [patents.google.com]
- 4. Recent developments on microwave-assisted organic synthesis of nitrogen- and oxygen-containing preferred heterocyclic scaffolds - PMC [pmc.ncbi.nlm.nih.gov]
- To cite this document: BenchChem. [Application Note: Microwave-Assisted Synthesis & Functionalization of Indazole-3-Carboxylic Acids]. BenchChem, [2026]. [\[Online PDF\]](#).

Available at: [<https://www.benchchem.com/product/b13543210/docs#application-note-microwave-assisted-synthesis-functionalization-of-indazole-3-carboxylic-acids>]

Disclaimer & Data Validity:

The information provided in this document is for Research Use Only (RUO) and is strictly not intended for diagnostic or therapeutic procedures. While BenchChem strives to provide accurate protocols, we make no warranties, express or implied, regarding the fitness of this product for every specific experimental setup.

Technical Support: The protocols provided are for reference purposes. Unsure if this reagent suits your experiment?

Need Industrial/Bulk Grade? [Request Custom Synthesis Quote](#)

BenchChem

Our mission is to be the trusted global source of essential and advanced chemicals, empowering scientists and researchers to drive progress in science and industry.

Contact

Address: 3281 E Guasti Rd
Ontario, CA 91761, United States
Phone: (601) 213-4426
Email: info@benchchem.com

[Contact our Ph.D. Support Team for a compatibility check](#)