

A Comparative Guide to the Mass Spectrometric Fragmentation of Brominated Chloro-ethanamines

Author: BenchChem Technical Support Team. **Date:** April 2026

Compound of Interest

Compound Name: *(R)-1-(2-Bromo-4-chlorophenyl)ethanamine*

Cat. No.: *B13541441*

[Get Quote](#)

This guide provides an in-depth comparison of the mass spectrometric fragmentation patterns of brominated chloro-ethanamines, offering valuable insights for researchers, scientists, and drug development professionals. By understanding the intricate fragmentation behaviors under different ionization techniques, analysts can achieve more accurate structural elucidation and confident identification of these complex molecules. This document moves beyond a simple listing of fragments to explain the causal factors behind the observed fragmentation, grounding the discussion in the fundamental principles of mass spectrometry and providing detailed, field-tested experimental protocols.

Introduction: The Analytical Challenge of Polyhalogenated Amines

Brominated chloro-ethanamines and their isomers represent a class of compounds with significant interest in various fields, including pharmaceutical development and environmental analysis. Their structures, containing two different halogens and a nitrogen atom, present a unique analytical challenge. The presence of bromine and chlorine, with their distinct isotopic

patterns, provides valuable clues for mass spectrometric identification. However, the interplay between the amine group and the two halogen atoms leads to competitive and often complex fragmentation pathways. This guide will dissect these pathways under both hard (Electron Ionization) and soft (Electrospray Ionization) ionization techniques, providing a framework for predicting and interpreting the resultant mass spectra.

A key aspect of analyzing these compounds is recognizing the influence of each functional group on the fragmentation process. The nitrogen atom, with its lone pair of electrons, readily stabilizes an adjacent positive charge, making α -cleavage a highly favorable pathway.[1] Concurrently, the carbon-halogen bonds are susceptible to cleavage, with the weaker carbon-bromine bond being more likely to break than the stronger carbon-chlorine bond.[2] The final fragmentation pattern is a result of the competition between these pathways, which is influenced by the specific isomer and the ionization energy.

Electron Ionization (EI) Mass Spectrometry: A Hard Ionization Approach

Electron Ionization (EI) is a high-energy ionization technique that induces extensive fragmentation, providing a detailed "fingerprint" of the molecule.[3] For brominated chloro-ethanamines, the resulting mass spectrum is a rich tapestry of fragments, each revealing a piece of the structural puzzle.

The Molecular Ion and Isotopic Patterns

The molecular ion ($M^{+\cdot}$) of a brominated chloro-ethanamine will exhibit a characteristic isotopic cluster due to the natural abundances of bromine ($^{79}\text{Br} \approx 50.7\%$, $^{81}\text{Br} \approx 49.3\%$) and chlorine ($^{35}\text{Cl} \approx 75.8\%$, $^{37}\text{Cl} \approx 24.2\%$).[2][4] This results in a series of peaks at M , $M+2$, and $M+4$, with their relative intensities providing a clear indication of the presence of one bromine and one chlorine atom.[2]

Ion	Contributing Isotopes	Expected Relative Intensity
M	^{79}Br , ^{35}Cl	~100%
M+2	^{81}Br , ^{35}Cl or ^{79}Br , ^{37}Cl	~75%
M+4	^{81}Br , ^{37}Cl	~25%

Competing Fragmentation Pathways in EI-MS

Upon ionization, brominated chloro-ethanamines will primarily undergo two competing fragmentation pathways: α -cleavage initiated by the nitrogen atom and cleavage of the carbon-halogen bonds.

Pathway A: α -Cleavage (Amine-directed fragmentation)

This is often the most dominant fragmentation pathway for aliphatic amines.^{[5][6]} The ionization of the nitrogen's lone pair electrons is followed by the cleavage of an adjacent carbon-carbon bond, leading to the formation of a resonance-stabilized iminium ion. For a generic brominated chloro-ethanamine, two primary α -cleavage fragments are possible, depending on which side of the nitrogen the cleavage occurs.

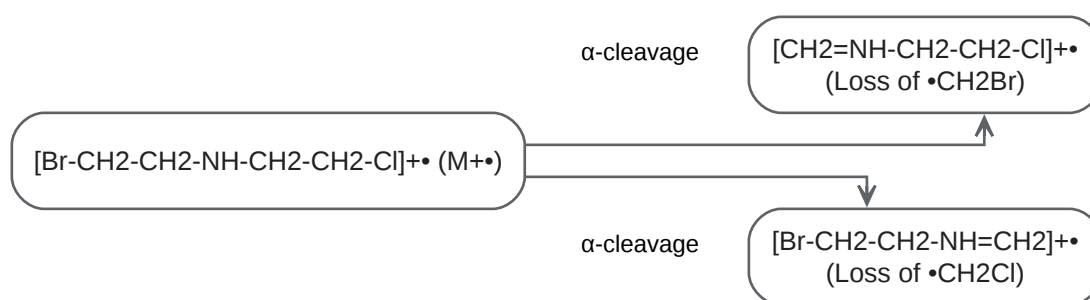

[Click to download full resolution via product page](#)

Caption: α -cleavage pathways in a brominated chloro-ethanamine.

The relative abundance of these fragments will depend on the stability of the expelled radical ($\bullet\text{CH}_2\text{Br}$ vs. $\bullet\text{CH}_2\text{Cl}$).

Pathway B: Halogen Loss (Charge-site initiation)

The cleavage of the carbon-halogen bond is another significant fragmentation route. Due to the lower bond dissociation energy of the C-Br bond compared to the C-Cl bond, the loss of a bromine radical is generally favored over the loss of a chlorine radical.[2]

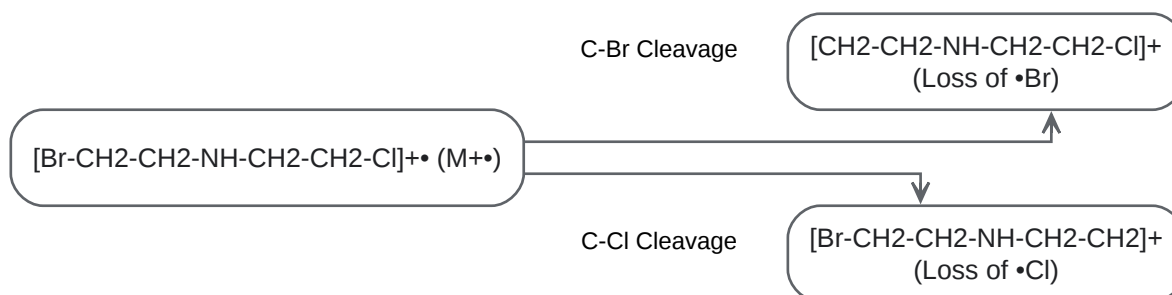

[Click to download full resolution via product page](#)

Caption: Halogen loss pathways in a brominated chloro-ethanamine.

Secondary Fragmentation

The primary fragment ions will undergo further fragmentation, leading to a complex but interpretable spectrum. For instance, the ion formed by the loss of a bromine radical can subsequently lose a molecule of ethylene via a cyclization reaction to form a stable aziridinium ion.

Electrospray Ionization (ESI) Tandem Mass Spectrometry (MS/MS): A Softer Approach

Electrospray ionization is a soft ionization technique that typically produces the protonated molecule, $[\text{M}+\text{H}]^+$, with minimal in-source fragmentation.[7] This is particularly useful for confirming the molecular weight of the analyte. Structural information is then obtained by subjecting the isolated $[\text{M}+\text{H}]^+$ ion to collision-induced dissociation (CID) in a tandem mass spectrometer (MS/MS).

Protonation Site and its Influence

In the acidic mobile phases commonly used for ESI, the ethanamine nitrogen is the most likely site of protonation. This protonation will direct the subsequent fragmentation pathways upon collisional activation.

Fragmentation of the Protonated Molecule $[M+H]^+$

The fragmentation of the $[M+H]^+$ ion of a brominated chloro-ethanamine will likely proceed through pathways that involve the newly acquired proton.

Pathway A: Loss of Halogen Acid

A common fragmentation pathway for protonated alkyl halides is the loss of a neutral halogen acid (HBr or HCl). Given the higher acidity of HBr, its loss might be favored.

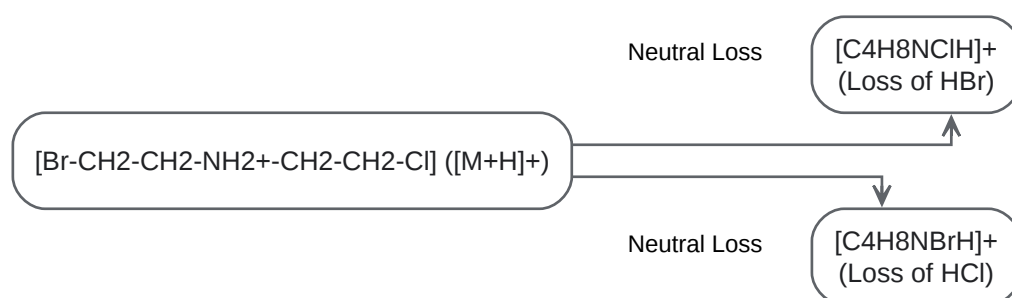

[Click to download full resolution via product page](#)

Caption: Neutral loss of halogen acids from the protonated molecule.

Pathway B: Amine-directed Fragmentation

Similar to EI, fragmentation can be initiated at the protonated amine. This can lead to the formation of cyclic aziridinium ions through intramolecular substitution of the halogen, which is a well-known reaction for nitrogen mustards.

Experimental Protocols

To ensure the generation of high-quality, reproducible data, the following experimental protocols are recommended.

GC-MS Analysis (EI)

This protocol is suitable for the analysis of volatile brominated chloro-ethanamines.

Sample Preparation:

- Prepare a 1 mg/mL stock solution of the analyte in a suitable solvent (e.g., methanol or acetonitrile).
- Dilute the stock solution to a final concentration of 1-10 µg/mL with the same solvent.
- Optional Derivatization for polar amines: For improved peak shape and volatility, derivatization with an agent like N,O-bis(trimethylsilyl)trifluoroacetamide (BSTFA) can be performed.[8]

GC-MS Conditions:

- Injection: 1 µL, splitless injection.
- Injector Temperature: 250 °C.
- GC Column: A mid-polarity column such as a 5% phenyl-methylpolysiloxane (e.g., DB-5ms, 30 m x 0.25 mm ID, 0.25 µm film thickness) is a good starting point.
- Carrier Gas: Helium at a constant flow of 1.2 mL/min.
- Oven Program:
 - Initial temperature: 50 °C, hold for 2 min.
 - Ramp to 280 °C at 15 °C/min.
 - Hold at 280 °C for 5 min.
- MS Transfer Line Temperature: 280 °C.
- MS Conditions (EI):
 - Ion Source: Electron Ionization (EI).
 - Source Temperature: 230 °C.
 - Electron Energy: 70 eV.
 - Mass Range: Scan from m/z 40 to 400.

- Data Acquisition: Full scan mode.

Caption: Workflow for GC-MS analysis of brominated chloro-ethanamines.

LC-MS/MS Analysis (ESI)

This protocol is suitable for the analysis of both volatile and non-volatile brominated chloro-ethanamines, particularly when analyzing complex matrices.

Sample Preparation:

- Prepare a 1 mg/mL stock solution of the analyte in methanol or acetonitrile.
- Dilute the stock solution to a final concentration of 10-100 ng/mL with the initial mobile phase composition.

LC-MS/MS Conditions:

- LC System: A high-performance liquid chromatography (HPLC) or ultra-high-performance liquid chromatography (UHPLC) system.
- Column: A C18 reversed-phase column (e.g., 100 mm x 2.1 mm, 1.8 µm particle size) is recommended for good retention of these relatively polar compounds.
- Mobile Phase A: 0.1% formic acid in water.
- Mobile Phase B: 0.1% formic acid in acetonitrile.
- Gradient:
 - 0-1 min: 5% B
 - 1-8 min: 5-95% B
 - 8-10 min: 95% B
 - 10.1-12 min: 5% B
- Flow Rate: 0.3 mL/min.

- Column Temperature: 40 °C.
- Injection Volume: 5 µL.
- MS Conditions (ESI):
 - Ion Source: Electrospray Ionization (ESI), positive ion mode.
 - Capillary Voltage: 3.5 kV.
 - Source Temperature: 150 °C.
 - Desolvation Temperature: 350 °C.
 - Gas Flows: Optimize for the specific instrument.
 - Data Acquisition:
 - Full Scan (MS1): m/z 50-500 to identify the [M+H]⁺ ion.
 - Tandem MS (MS/MS): Product ion scan of the [M+H]⁺ precursor ion. Use a range of collision energies (e.g., 10-40 eV) to observe the full fragmentation pattern.

Caption: Workflow for LC-MS/MS analysis of brominated chloro-ethanamines.

Data Interpretation and Comparison

The following table summarizes the expected key fragments for a generic N-(2-bromoethyl)-2-chloroethanamine under EI and ESI conditions. The exact m/z values will depend on the specific isomer.

Ionization	Fragmentation Pathway	Key Fragment Ion	Comments
EI	α -Cleavage	$[\text{CH}_2=\text{NH}-\text{CH}_2-\text{CH}_2-\text{Cl}]^+$	Loss of $\bullet\text{CH}_2\text{Br}$. Fragment will show a 3:1 isotopic pattern for Cl.
EI	α -Cleavage	$[\text{Br}-\text{CH}_2-\text{CH}_2-\text{NH}=\text{CH}_2]^+$	Loss of $\bullet\text{CH}_2\text{Cl}$. Fragment will show a 1:1 isotopic pattern for Br.
EI	Halogen Loss	$[\text{C}_4\text{H}_9\text{NCl}]^+$	Loss of $\bullet\text{Br}$. Fragment will show a 3:1 isotopic pattern for Cl. Expected to be more abundant than loss of $\bullet\text{Cl}$.
EI	Halogen Loss	$[\text{C}_4\text{H}_9\text{NBr}]^+$	Loss of $\bullet\text{Cl}$. Fragment will show a 1:1 isotopic pattern for Br.
ESI-MS/MS	Neutral Loss	$[\text{C}_4\text{H}_8\text{NClH}]^+$	Loss of HBr from $[\text{M}+\text{H}]^+$. Fragment will show a 3:1 isotopic pattern for Cl.
ESI-MS/MS	Neutral Loss	$[\text{C}_4\text{H}_8\text{NBrH}]^+$	Loss of HCl from $[\text{M}+\text{H}]^+$. Fragment will show a 1:1 isotopic pattern for Br.

By comparing the fragmentation patterns obtained from both EI-MS and ESI-MS/MS, a comprehensive structural characterization of brominated chloro-ethanamines can be achieved. The high-energy fragmentation of EI provides a detailed fingerprint, while the controlled fragmentation of ESI-MS/MS allows for the elucidation of specific fragmentation pathways from the protonated molecule.

Conclusion

The mass spectrometric analysis of brominated chloro-ethanamines is a multifaceted challenge that can be effectively addressed through a systematic approach. By leveraging the distinct isotopic signatures of bromine and chlorine, and understanding the competitive nature of amine-directed α -cleavage and halogen loss, researchers can confidently interpret the resulting mass spectra. The detailed experimental protocols provided in this guide offer a robust starting point for the analysis of these and other polyfunctionalized compounds. As with any analytical endeavor, a combination of sound experimental design, careful data interpretation, and a foundational understanding of fragmentation mechanisms is paramount to success.

References

- D'Agostino, P. A., & Hancock, J. R. (2002). Analysis of nerve agent degradation products by packed capillary liquid chromatography-electrospray mass spectrometry.
- PubChem. (n.d.). N-(2-bromoethyl)-2-chloroethanamine. National Center for Biotechnology Information. Retrieved from [\[Link\]](#)
- Chemguide. (n.d.). The M+2 peak in mass spectra. Retrieved from [\[Link\]](#)
- Bandu, R., Ahn, H. S., Lee, J. W., Kim, Y. W., Choi, S. H., Kim, H. J., ... & Kim, K. H. (2015). Liquid Chromatography Electrospray Ionization Tandem Mass Spectrometric (LC/ESI-MS/MS) Study for the Identification and Characterization of In Vivo Metabolites of Cisplatin in Rat Kidney Cancer Tissues: Online Hydrogen/Deuterium (H/D) Exchange Study. PLoS ONE, 10(8), e0134991.
- PubChemLite. (n.d.). N-(2-bromoethyl)-p-chloro-n-ethylbenzylamine (C11H15BrClN). Retrieved from [\[Link\]](#)
- NIST. (n.d.). Bis(2-chloroethyl)ethylamine. In NIST Chemistry WebBook. National Institute of Standards and Technology. Retrieved from [\[Link\]](#)
- University of Arizona. (n.d.). Mass Spectrometry: Fragmentation. Retrieved from [\[Link\]](#)
- de Souza, G. E., de Almeida, G. S., de Oliveira, D. N., & Jorge, M. A. (2018).
- LibreTexts. (2024, September 30). 12.3: Mass Spectrometry of Some Common Functional Groups. Chemistry LibreTexts. Retrieved from [\[Link\]](#)

- Sharma, G. V. M., Reddy, K. S., Chander, C. P., & Srinivas, R. (2012). Electrospray ionization tandem mass spectrometry of protonated and alkali-cationized Boc-N-protected hybrid peptides containing repeats of D-Ala-APyC and APyC-D-Ala: formation of $[b(n-1) + OCH_3 + Na]^+$ and $[b(n-1) + OH + Na]^+$ ions. *Rapid communications in mass spectrometry*, 26(22), 2591-2600.
- Paizs, B., & Suhai, S. (2005). Fragmentation of protonated peptides. *Mass spectrometry reviews*, 24(4), 508-548.
- Wang, R., Li, L., & Dong, F. (2020). A Liquid Chromatography–Tandem Mass Spectrometry Method for the Analysis of Primary Aromatic Amines in Human Urine. *Toxics*, 8(4), 93.
- Chad's Prep. (2018, September 20). 14.6b Fragmentation Patterns of Alkyl Halides, Alcohols, and Amines | Mass Spectrometry [Video]. YouTube. [[Link](#)]
- Restek. (n.d.). A Guide to the Analysis of Halogenated Environmental Pollutants Using Electron Capture Detection. Retrieved from [[Link](#)]
- Ikeshima, E., Min, J. Z., & Umehara, T. (2021). High throughput LC/ESI-MS/MS method for simultaneous analysis of 20 oral molecular-targeted anticancer drugs and the active metabolite of sunitinib in human plasma. *Journal of pharmaceutical and biomedical analysis*, 193, 113739.
- Le, V. T., & Nguyen, T. H. (2022). Analysis of highly polar pesticides in foods by LC-MS/MS. *Vietnam Journal of Science and Technology*, 60(6), 949.
- Jorge, M. A., de Souza, G. E., de Almeida, G. S., & de Oliveira, D. N. (2018).
- Hida, M., & Kudo, K. (2017). Gas Chromatography Mass Spectrometry (GC-MS) for Identification of Designer Stimulants Including 2C Amines, NBOMe Compounds, and Cathinones in Urine. *Current protocols in toxicology*, 74(1), 31-1.
- LibreTexts. (2022, July 3). 6.5: Amine Fragmentation. Chemistry LibreTexts. Retrieved from [[Link](#)]
- Takhistov, V. V., & Pleshkova, A. P. (2024). Protocol for Structure Determination of Unknowns by EI Mass Spectrometry. III. Diagnostic Ions in Multiple Ring Carbo- and Heterocycles, and Mono-Functional Derivatives.
- E-GyanKosh. (n.d.). General Fragmentation Rules. Retrieved from [[Link](#)]
- Waters Corporation. (n.d.). Evaluation of the Performance of a Method for the Determination of Highly Polar, Anionic Pesticides in Foodstuffs Using LC-MS/MS. Retrieved from [[Link](#)]

- Van de Walle, M., & De Clercq, P. (2004). LC-MS/MS method for the confirmatory determination of aromatic amines and its application in textile analysis. *Analytical and bioanalytical chemistry*, 378(3), 814-820.
- LibreTexts. (2022, July 3). 6.2: Fragmentation. Chemistry LibreTexts. Retrieved from [\[Link\]](#)
- Abraham, R. M. (2007). The Development of a GC/MS Protocol for the Analysis of Polysaccharides in *Echinacea purpurea*. Digital Showcase @ University of Lynchburg.
- Khoomrung, S., & Jeyachoke, N. (2021). UPLC-ESI-MRM/MS for Absolute Quantification and MS/MS Structural Elucidation of Six Specialized Pyranonaphthoquinone Metabolites From *Ventilago harmandiana*. *Frontiers in plant science*, 11, 613853.
- Shimadzu. (n.d.). Quantitative Screening of Twenty Six Aromatic Amines Originated from Azo Dyes by LC/MS Method. Retrieved from [\[Link\]](#)

Need Custom Synthesis?

BenchChem offers custom synthesis for rare earth carbides and specific isotopic labeling.

Email: info@benchchem.com or [Request Quote Online](#).

Sources

- 1. chem.libretexts.org [chem.libretexts.org]
- 2. pdf.benchchem.com [pdf.benchchem.com]
- 3. chemistry.miamioh.edu [chemistry.miamioh.edu]
- 4. chemguide.co.uk [chemguide.co.uk]
- 5. chem.libretexts.org [chem.libretexts.org]
- 6. m.youtube.com [m.youtube.com]
- 7. pdf.benchchem.com [pdf.benchchem.com]
- 8. scispace.com [scispace.com]
- To cite this document: BenchChem. [A Comparative Guide to the Mass Spectrometric Fragmentation of Brominated Chloro-ethanamines]. BenchChem, [2026]. [Online PDF]. Available at: [<https://www.benchchem.com/product/b13541441/docs#a-comparative-guide-to-the-mass-spectrometric-fragmentation-of-brominated-chloro-ethanamines>]

Disclaimer & Data Validity:

The information provided in this document is for Research Use Only (RUO) and is strictly not intended for diagnostic or therapeutic procedures. While BenchChem strives to provide accurate protocols, we make no warranties, express or implied, regarding the fitness of this product for every specific experimental setup.

Technical Support: The protocols provided are for reference purposes. Unsure if this reagent suits your experiment?

Need Industrial/Bulk Grade? [Request Custom Synthesis Quote](#)

BenchChem

Our mission is to be the trusted global source of essential and advanced chemicals, empowering scientists and researchers to drive progress in science and industry.

Contact

Address: 3281 E Guasti Rd
Ontario, CA 91761, United States
Phone: (601) 213-4426
Email: info@benchchem.com

[Contact our Ph.D. Support Team for a compatibility check](#)