

Technical Support Center: Vilsmeier-Haack Formylation of Pyrazoles

Author: BenchChem Technical Support Team. **Date:** May 2026

Compound of Interest

Compound Name:	1-(4-methoxyphenyl)-1H-pyrazole-4-carbaldehyde
CAS No.:	99984-70-0
Cat. No.:	B1598736

[Get Quote](#)

Welcome to the technical support center for the Vilsmeier-Haack (V-H) formylation of pyrazoles. This guide is designed for researchers, medicinal chemists, and process development professionals who are utilizing this powerful reaction to introduce formyl groups onto the pyrazole scaffold, a critical step in the synthesis of many pharmaceutical intermediates. Here, we move beyond simple protocols to address the nuanced challenges and unexpected outcomes you may encounter in the lab. Our approach is rooted in a deep understanding of the reaction mechanism and extensive hands-on experience.

Frequently Asked Questions (FAQs)

Q1: What is the Vilsmeier-Haack reaction and why is it used for pyrazoles?

The Vilsmeier-Haack reaction is a robust method for the formylation of electron-rich aromatic and heteroaromatic compounds.^[1] The reaction employs a Vilsmeier reagent, typically formed in situ from a substituted amide like N,N-dimethylformamide (DMF) and a halogenating agent,

most commonly phosphorus oxychloride (POCl_3).^[2] This combination generates a chloroiminium ion (the Vilsmeier reagent), which is the active electrophile.

For pyrazoles, this reaction is particularly valuable. The pyrazole ring system, while aromatic, has specific electronic characteristics. The two nitrogen atoms influence the electron density of the ring carbons, making the C-4 position the most electron-rich and thus highly susceptible to electrophilic attack.^[3] This inherent reactivity leads to a highly regioselective formylation, almost exclusively yielding pyrazole-4-carbaldehydes, which are versatile building blocks in medicinal chemistry.^{[1][4]}

Q2: I'm setting up the reaction for the first time. What is a reliable, general protocol?

A robust starting point for the formylation of a substituted pyrazole is as follows. This protocol is a synthesis of common procedures and should be optimized for your specific substrate.

Experimental Protocol: General Vilsmeier-Haack Formylation of a Pyrazole

Materials:

- Substituted Pyrazole (1.0 eq)
- Anhydrous N,N-Dimethylformamide (DMF) (Solvent and Reagent)
- Phosphorus Oxychloride (POCl_3) (1.5 - 4.0 eq)
- Dichloromethane (DCM) or Chloroform (for extraction)
- Saturated Sodium Bicarbonate Solution or Sodium Carbonate (solid)
- Crushed Ice / Ice Water
- Anhydrous Magnesium Sulfate (MgSO_4) or Sodium Sulfate (Na_2SO_4)

Procedure:

- Vilsmeier Reagent Preparation:
 - In a flame-dried, three-necked round-bottom flask equipped with a magnetic stirrer, thermometer, and a dropping funnel under an inert atmosphere (e.g., Nitrogen or Argon), add anhydrous DMF.
 - Cool the DMF in an ice-salt bath to 0 °C (or lower, to -10 °C, for better control).[1]
 - Slowly add POCl₃ (1.5 - 4.0 eq) dropwise via the dropping funnel, ensuring the internal temperature does not exceed 10 °C. The formation of a viscous, white to pale-yellow solid or slurry indicates the formation of the Vilsmeier reagent.[1]
 - Stir the mixture at 0 °C for an additional 15-30 minutes after the addition is complete.
- Formylation Reaction:
 - Dissolve the pyrazole substrate (1.0 eq) in a minimal amount of anhydrous DMF.
 - Add the pyrazole solution dropwise to the pre-formed Vilsmeier reagent at 0 °C.
 - After the addition, allow the reaction to warm to room temperature and then heat to the desired temperature (typically between 70-120 °C).[4] Monitor the reaction progress by Thin Layer Chromatography (TLC).
- Work-up and Hydrolysis:
 - Once the reaction is complete (as indicated by TLC, showing consumption of the starting material), cool the reaction mixture to room temperature.
 - Carefully and slowly pour the reaction mixture onto a large excess of crushed ice or into vigorously stirred ice-cold water. This step is highly exothermic and hydrolyzes the intermediate iminium salt.
 - Neutralize the acidic solution by slowly adding a base, such as solid sodium carbonate or a saturated solution of sodium bicarbonate, until the pH is > 8-10.[1] This will precipitate the crude product.
 - Stir the mixture for 30-60 minutes to ensure complete hydrolysis and precipitation.

- Isolation and Purification:
 - If a solid precipitates, collect it by vacuum filtration, wash with cold water, and dry.
 - If the product is an oil or remains in solution, extract the aqueous mixture with a suitable organic solvent (e.g., DCM, Chloroform, or Ethyl Acetate) (3 x volumes).
 - Combine the organic layers, dry over anhydrous MgSO_4 or Na_2SO_4 , filter, and concentrate under reduced pressure.
 - Purify the crude product by column chromatography on silica gel or recrystallization.

Troubleshooting Guide: Common Issues and Solutions

Issue 1: No reaction or very low conversion of starting material.

This is the most common issue, particularly with pyrazoles bearing electron-withdrawing groups (EWGs) or bulky substituents.

Causality: The Vilsmeier-Haack reaction is an electrophilic aromatic substitution. EWGs (like $-\text{NO}_2$, $-\text{CF}_3$, or even some aromatic substituents) deactivate the pyrazole ring, making it less nucleophilic and therefore less reactive towards the Vilsmeier reagent.^[4] Low temperatures can also be insufficient to overcome the activation energy barrier for these less reactive substrates.^[4]

Solutions:

- **Increase Reaction Temperature:** This is the most effective first step. While some activated pyrazoles react at room temperature or 70°C , deactivated substrates often require higher temperatures. Successful formylations have been reported at temperatures as high as 120°C .^[4] One study noted that a reaction failed at 70°C but proceeded to give a 55% yield when heated to 120°C .^[4]
- **Increase Reagent Stoichiometry:** Using a larger excess of the Vilsmeier reagent can drive the equilibrium towards the product.

- Increase the equivalents of POCl₃. Some protocols have used up to 10 equivalents of POCl₃ to improve yields for challenging substrates.[3]
- Increase the amount of DMF. Using a 5-fold excess of DMF along with a 2-fold excess of POCl₃ has been shown to significantly improve yields compared to smaller excesses.[4]
- Verify Reagent Quality: Ensure that the DMF is anhydrous. Water will quench the Vilsmeier reagent. POCl₃ should be fresh and colorless; aged, yellow POCl₃ may have lower reactivity.

Condition	Temperature	POCl ₃ (eq.)	DMF (eq.)	Result
Initial Trial	70 °C	2.0	2.0	No Product Observed[4]
Optimized 1	120 °C	2.0	2.0	32% Yield[4]
Optimized 2	120 °C	2.0	5.0	55% Yield[4]
Optimized 3	Reflux	10.0	Solvent	90% Yield (from 60%)[3]

A summary of optimization strategies for a low-reactivity pyrazole substrate.

Issue 2: Formation of unexpected byproducts.

Besides the desired 4-formylpyrazole, other products may appear on your TLC or in your NMR spectrum.

Causality & Solutions:

- Chlorination: If your pyrazole has other reactive functional groups, such as a hydroxyl group, it can be converted to a chloride by POCl₃. For instance, a 2-hydroxyethyl substituent can be converted to a 2-chloroethyl group.[4]

- Solution: Protect the sensitive functional group before the V-H reaction. If this is not feasible, be prepared to isolate the chlorinated product.
- Hydroxymethylation: Prolonged heating of DMF can cause slight decomposition to generate traces of formaldehyde. This can lead to a competing hydroxymethylation reaction at the C-4 position.[4]
 - Solution: Minimize reaction time once the starting material is consumed. Use the lowest effective temperature to reduce the rate of DMF decomposition.
- Dealkylation: Bulky groups, particularly N-tert-butyl substituents, can be cleaved under the acidic and high-temperature conditions of the reaction, leading to an N-H pyrazole.[4]
 - Solution: If dealkylation is a problem, consider using a more robust N-substituent or explore alternative formylation methods that do not require such harsh conditions.
- Reactions at other Substituents: Substituents with reactive sites, such as a chloroethyl group, can undergo elimination to form a vinyl group, which may then be subsequently formylated.[4]
 - Solution: This highlights the importance of thorough characterization (NMR, MS) of all isolated products to understand the complete reaction pathway.

Visualizing the Process

The Vilsmeier-Haack Mechanism on Pyrazole

The reaction proceeds via the formation of the Vilsmeier reagent, followed by electrophilic attack by the pyrazole ring and subsequent hydrolysis.

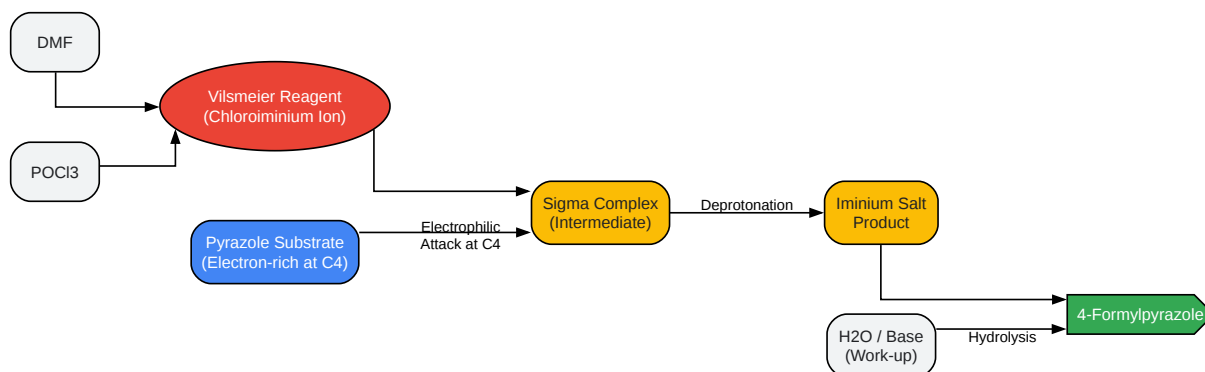

[Click to download full resolution via product page](#)

Caption: Mechanism of pyrazole formylation.

Troubleshooting Decision Workflow

When your reaction doesn't proceed as expected, a logical workflow can help diagnose the issue.

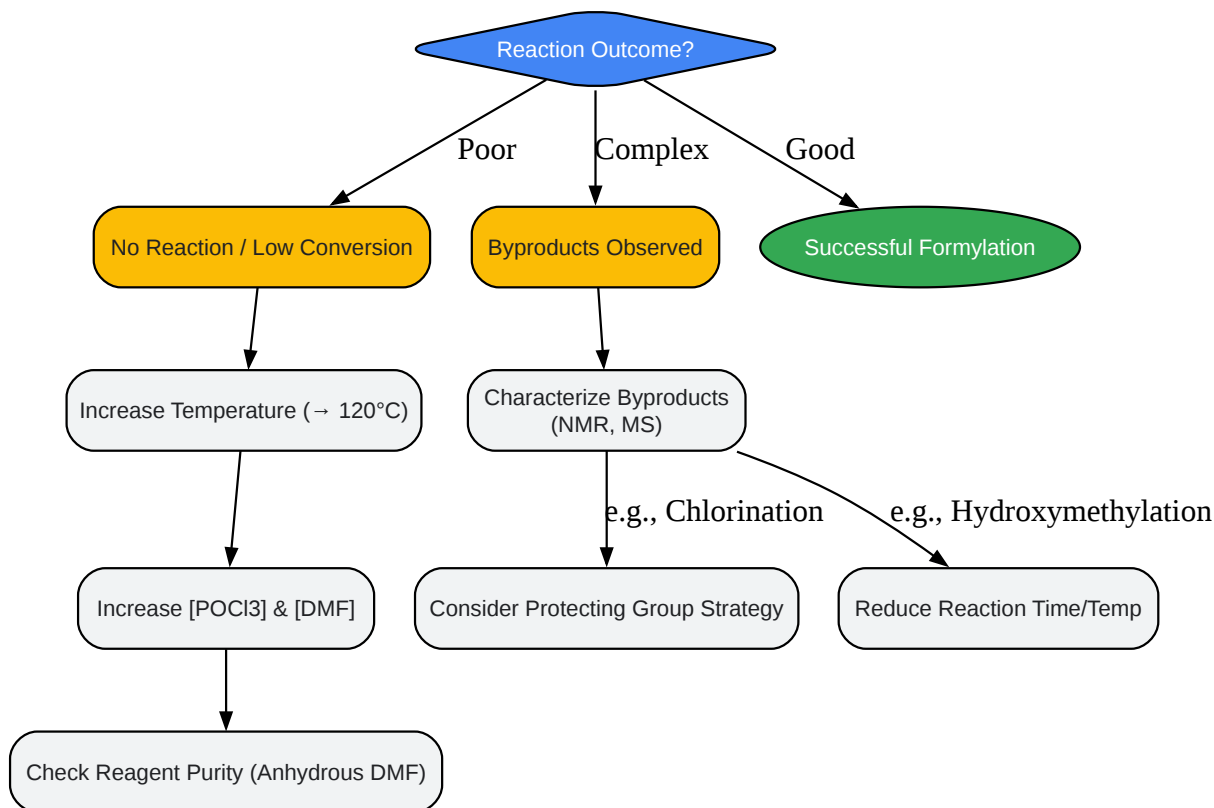

[Click to download full resolution via product page](#)

Caption: A decision tree for troubleshooting common issues.

References

- Popov, A. V., et al. (2019). Synthesis of poly-functionalized pyrazoles under Vilsmeier-Haack reaction conditions. *Arkivoc*, 2019(5), 184-203. Available from: [\[Link\]](#)
- Varvuolyté, G., et al. (2024). 3-(2-Chloroethoxy)-1-(4-methoxyphenyl)-1H-pyrazole-4-carbaldehyde. *Molbank*, 2024(1), M1782. Available from: [\[Link\]](#)
- Sharma, P., & Kumar, A. (2023). Unravelling the synthetic and therapeutic aspects of five, six and fused heterocycles using Vilsmeier–Haack reagent. *RSC Advances*, 13(40), 28247-28286. Available from: [\[Link\]](#)

- Chemistry Steps. (n.d.). Vilsmeier-Haack Reaction. Available from: [[Link](#)]
- Patil, S. A., et al. (2012). REVIEW ARTICLE ON VILSMEIER-HAACK REACTION. International Journal of Pharmaceutical, Chemical and Biological Sciences, 2(3), 343-353.
- Singh, K., et al. (2009). Vilsmeier—Haack Reaction on Hydrazones: A Convenient Synthesis of 4-Formylpyrazoles. Journal of Chemical Research, 2009(10), 604-605.

Need Custom Synthesis?

BenchChem offers custom synthesis for rare earth carbides and specific isotopic labeling.

Email: info@benchchem.com or [Request Quote Online](#).

Sources

- 1. [3-\(2-Chloroethoxy\)-1-\(4-methoxyphenyl\)-1H-pyrazole-4-carbaldehyde \[mdpi.com\]](#)
- 2. [Vilsmeier-Haack Reaction - Chemistry Steps \[chemistrysteps.com\]](#)
- 3. [Unravelling the synthetic and therapeutic aspects of five, six and fused heterocycles using Vilsmeier—Haack reagent - PMC \[pmc.ncbi.nlm.nih.gov\]](#)
- 4. [pdfs.semanticscholar.org \[pdfs.semanticscholar.org\]](#)
- To cite this document: BenchChem. [Technical Support Center: Vilsmeier-Haack Formylation of Pyrazoles]. BenchChem, [2026]. [Online PDF]. Available at: [<https://www.benchchem.com/product/b1598736/docs#technical-support-center-vilsmeier-haack-formylation-of-pyrazoles>]

Disclaimer & Data Validity:

The information provided in this document is for Research Use Only (RUO) and is strictly not intended for diagnostic or therapeutic procedures. While BenchChem strives to provide accurate protocols, we make no warranties, express or implied, regarding the fitness of this product for every specific experimental setup.

Technical Support: The protocols provided are for reference purposes. Unsure if this reagent suits your experiment?

Need Industrial/Bulk Grade? [Request Custom Synthesis Quote](#)

BenchChem

Our mission is to be the trusted global source of essential and advanced chemicals, empowering scientists and researchers to drive progress in science and industry.

Contact

Address: 3281 E Guasti Rd

Ontario, CA 91761, United States

Phone: (601) 213-4426

Email: info@benchchem.com

[Contact our Ph.D. Support Team for a compatibility check](#)