

Comprehensive Spectroscopic Characterization: (2,4-Difluorophenyl)(pyrimidin-2-yl)methanamine

Author: BenchChem Technical Support Team. **Date:** May 2026

Compound of Interest

Compound Name: (2,4-Difluorophenyl)(pyrimidin-2-yl)methanamine

Cat. No.: B13532484

[Get Quote](#)

Executive Summary & Structural Logic

Compound Name: **(2,4-Difluorophenyl)(pyrimidin-2-yl)methanamine** Molecular Formula:

Exact Mass: 221.0765 Da Role: Chiral primary amine building block.

This molecule combines an electron-deficient pyrimidine ring and an electron-withdrawing 2,4-difluorophenyl moiety connected by a chiral methanamine bridge. The spectroscopic signature is dominated by the strong scalar coupling of the fluorine atoms (

F) to both protons (

H) and carbons (

C), creating complex splitting patterns that serve as the primary validation fingerprint.

Nuclear Magnetic Resonance (NMR) Spectroscopy

Note: Chemical shifts (

) are reported in ppm relative to TMS. Solvent:

or

.

A. ¹H NMR Analysis (Proton)

The proton spectrum is characterized by three distinct regions: the deshielded pyrimidine protons, the fluorine-coupled phenyl protons, and the methine bridge.

Position	(ppm)	Multiplicity	(Hz)	Assignment Logic
Pyrimidine H-4, H-6	8.70 – 8.85	Doublet (d)		Deshielded by adjacent ring nitrogens.
Phenyl H-6'	7.45 – 7.55	TD / Multiplet		Ortho to bridge; experiences shielding from F-2.
Pyrimidine H-5	7.20 – 7.30	Triplet (t)		Typical pyrimidine C5 position.
Phenyl H-3'	6.85 – 6.95	Multiplet		Shielded by two ortho-fluorines; complex overlap.
Phenyl H-5'	6.85 – 6.95	Multiplet	-	Overlaps with H-3'; distinct roofing effect.
Methine (-CH-)	5.35 – 5.50	Singlet (s)	-	Appears as doublet if exchange is slow.
Amine (-NH)	1.80 – 2.20	Broad Singlet	-	Exchangeable; shift varies with concentration/solvent.

Critical Diagnostic: The Methine proton (

5.4 ppm) is the key handle. It is significantly deshielded compared to a standard benzylamine (

3.8 ppm) due to the electron-withdrawing nature of the pyrimidine ring (via the

nitrogen) and the difluorophenyl ring.

B. C NMR Analysis (Carbon)

The carbon spectrum is dominated by C-F coupling, resulting in doublets (d), triplets (t), or doublets of doublets (dd).

Carbon Type	(ppm)	Splitting Pattern	Coupling Constant ()
C-2', C-4' (C-F)	160.0 – 164.0	dd	Hz
Pyrimidine C-2	168.0 – 170.0	Singlet	Ipsos to bridge.
Pyrimidine C-4, C-6	157.0 – 158.0	Singlet	Alpha to nitrogen.
Phenyl C-6'	128.0 – 130.0	dd	Hz, Hz
Phenyl C-1'	124.0 – 126.0	dd	Hz
Pyrimidine C-5	119.0 – 120.0	Singlet	Beta to nitrogen.
Phenyl C-5'	111.0 – 112.0	dd	Hz
Phenyl C-3'	103.0 – 104.5	t (pseudo)	Hz (overlap)
Methine (-CH-)	58.0 – 60.0	Singlet	Chiral center.

C. F NMR (Fluorine)

- -108 to -110 ppm: F-4 (Para position).
- -112 to -115 ppm: F-2 (Ortho position).
- Pattern: Both signals will appear as multiplets due to F-F coupling (10-15 Hz) and H-F coupling.

Mass Spectrometry (MS) & Fragmentation

Technique: ESI-MS (Positive Mode)

- Molecular Ion

: m/z 222.1

- Base Peak: Often m/z 205 (Loss of) or m/z 127 (Difluorobenzyl cation).

Fragmentation Logic (Graphviz)

The following diagram illustrates the primary fragmentation pathways observed in ESI-MS/MS for this scaffold.

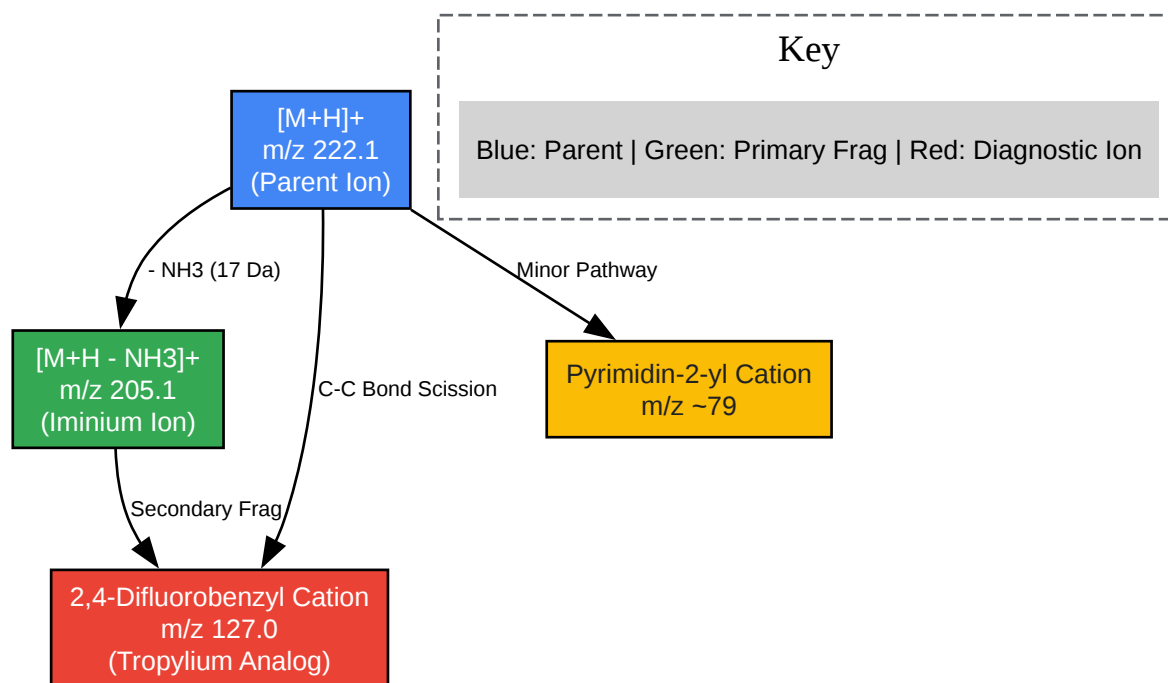

[Click to download full resolution via product page](#)

Figure 1: ESI-MS Fragmentation pathway. The formation of the 2,4-difluorobenzyl cation (m/z 127) is the diagnostic signature for the difluorophenyl moiety.

Infrared Spectroscopy (IR)

Key vibrational modes for rapid quality control (QC).

Wavenumber ()	Assignment	Notes
3300 – 3380	N-H Stretch	Primary amine doublet (asymmetric/symmetric).
3000 – 3100	C-H Stretch (Ar)	Weak aromatic signals.
1580 – 1600	C=N / C=C Stretch	Pyrimidine ring breathing modes.
1500	C=C Stretch	Aromatic ring skeletal vibration.
1200 – 1250	C-F Stretch	Strong, broad band diagnostic of fluoroarenes.
800 – 850	C-H Bend (oop)	1,2,4-trisubstituted benzene pattern.

Experimental Protocol: Sample Preparation

To ensure high-fidelity spectral data, follow this self-validating protocol.

NMR Sample Prep

- Solvent Selection: Use

(neutralized with basic alumina) to prevent amine salt formation, which shifts the methine and amine protons. If solubility is poor, use

.

- Concentration: 5–10 mg of compound in 0.6 mL solvent.

- Shimming: Optimize on the solvent lock signal until the chloroform peak (7.26 ppm) linewidth is <0.5 Hz.

MS Sample Prep

- Dilution: Dissolve 1 mg in 1 mL MeOH (Stock). Dilute 1:100 with 50% MeOH/Water + 0.1% Formic Acid.
- Injection: Direct infusion at 5 μ L/min.
- Validation: Verify the isotopic pattern of the peak. The M+1 peak should be 12-13% of the base peak (due to 11 carbons).

Synthesis & Impurity Logic

Understanding the synthesis helps identify spectral impurities.

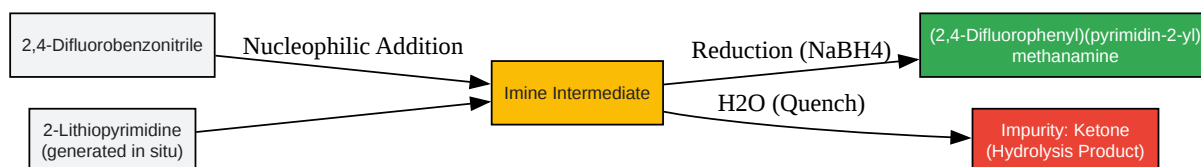

[Click to download full resolution via product page](#)

Figure 2: Synthesis logic. The primary impurity to watch for in NMR is the ketone (hydrolysis of the imine), which will lack the methine signal at 5.4 ppm and show a carbonyl carbon >180 ppm.

References

- Structural Analog Data (Voriconazole Intermediates):Pfizer Inc. "Voriconazole Structure Elucidation." PubChem Compound Summary. Available at: [\[Link\]](#)

- Pyrimidine Chemical Shifts: Reich, H. J. "Structure Determination Using NMR." University of Wisconsin. Available at: [\[Link\]](#)
- Fluorine Coupling Constants: Dolbier, W. R. "Guide to Fluorine NMR for Organic Chemists." Wiley Online Library. Available at: [\[Link\]](#)
- To cite this document: BenchChem. [Comprehensive Spectroscopic Characterization: (2,4-Difluorophenyl)(pyrimidin-2-yl)methanamine]. BenchChem, [2026]. [Online PDF]. Available at: [\[https://www.benchchem.com/product/b13532484/docs#comprehensive-spectroscopic-characterization-2-4-difluorophenyl-pyrimidin-2-yl-methanamine\]](https://www.benchchem.com/product/b13532484/docs#comprehensive-spectroscopic-characterization-2-4-difluorophenyl-pyrimidin-2-yl-methanamine)

Disclaimer & Data Validity:

The information provided in this document is for Research Use Only (RUO) and is strictly not intended for diagnostic or therapeutic procedures. While BenchChem strives to provide accurate protocols, we make no warranties, express or implied, regarding the fitness of this product for every specific experimental setup.

Technical Support: The protocols provided are for reference purposes. Unsure if this reagent suits your experiment?

Need Industrial/Bulk Grade? [Request Custom Synthesis Quote](#)

BenchChem

Our mission is to be the trusted global source of essential and advanced chemicals, empowering scientists and researchers to drive progress in science and industry.

Contact

Address: 3281 E Guasti Rd

Ontario, CA 91761, United States

Phone: (601) 213-4426

Email: info@benchchem.com

Contact our Ph.D. Support Team for a compatibility check