

Technical Guide: Structure-Activity Relationship of 3-(3-Chloro-4-methylphenyl)piperidine

Author: BenchChem Technical Support Team. **Date:** May 2026

Compound of Interest

Compound Name: 3-(3-Chloro-4-methylphenyl)piperidine

Cat. No.: B13531470

[Get Quote](#)

Executive Summary & Pharmacological Context

Compound Class: 3-Arylpiperidine (3-AP). Primary Target: Monoamine Transporters (DAT/NET) and Dopamine Autoreceptors (D2/D3). Chemical Space: Psychostimulants / Dopamine Stabilizers.

3-(3-Chloro-4-methylphenyl)piperidine represents a specific lipophilic optimization of the 3-phenylpiperidine scaffold. Unlike its 4-phenylpiperidine isomers (often associated with opioid activity, e.g., Pethidine) or 2-substituted analogs (e.g., Methylphenidate), the 3-substitution pattern typically confers selectivity for the Dopamine Transporter (DAT) and Norepinephrine Transporter (NET), often with a "dopamine stabilizer" profile characteristic of agents like (-)-OSU-6162 or 3-PPP.

This guide analyzes the specific steric and electronic contributions of the 3-Chloro and 4-Methyl substituents, providing a rationale for their inclusion in lead optimization to enhance lipophilicity, metabolic stability, and binding affinity.

Chemical Structure & Topological Analysis

The molecule consists of a piperidine ring substituted at the C3 position with a phenyl ring bearing a chlorine atom at the meta (3') position and a methyl group at the para (4') position.

Substituent Effects (SAR Logic)

The 3-Cl, 4-Me substitution pattern is a classic medicinal chemistry tactic ("Hybrid Isostere") designed to optimize the phenyl ring's interaction with the hydrophobic S1 pocket of the DAT.

Substituent	Position	Electronic Effect	Steric/Lipophilic Effect	Pharmacological Impact
Piperidine Nitrogen	N1	Proton acceptor (pKa ~9-10)	Ionic interaction site	Critical salt bridge formation with Asp79 in DAT.
Phenyl Ring	C3 (Piperidine)	-system	Scaffold orientation	C3 positioning favors DAT/NET selectivity over SERT/Opioid receptors compared to C4 isomers.
Chlorine	meta (3')	Electron Withdrawing (-I)	Lipophilic ()	Enhances hydrophobic contact; halogen bonding potential with serine residues in the binding pocket.
Methyl	para (4')	Weak Electron Donor (+I)	Lipophilic ()	Metabolic Blockade: Prevents rapid p-hydroxylation (CYP450 degradation), significantly extending half-life ().

Chirality & Stereochemistry

The C3 position is a chiral center. Based on the 3-phenylpiperidine class (e.g., Preclamol, 3-PPP):

- (+) Enantiomer (3S): Typically exhibits higher affinity for DAT and stimulant-like properties.
- (-) Enantiomer (3R): Often acts as a partial agonist or antagonist (dopamine stabilizer profile).
- Recommendation: Asymmetric synthesis or chiral resolution is required for definitive pharmacological characterization.

Synthesis Protocol: Rhodium-Catalyzed Arylation

While traditional Grignard routes exist, they often suffer from low yields and racemization. The following protocol utilizes a Rhodium-catalyzed conjugate addition to ensure regioselectivity and high yield, adapted from modern 3-arylpiperidine methodologies.

Reaction Scheme (Graphviz Visualization)

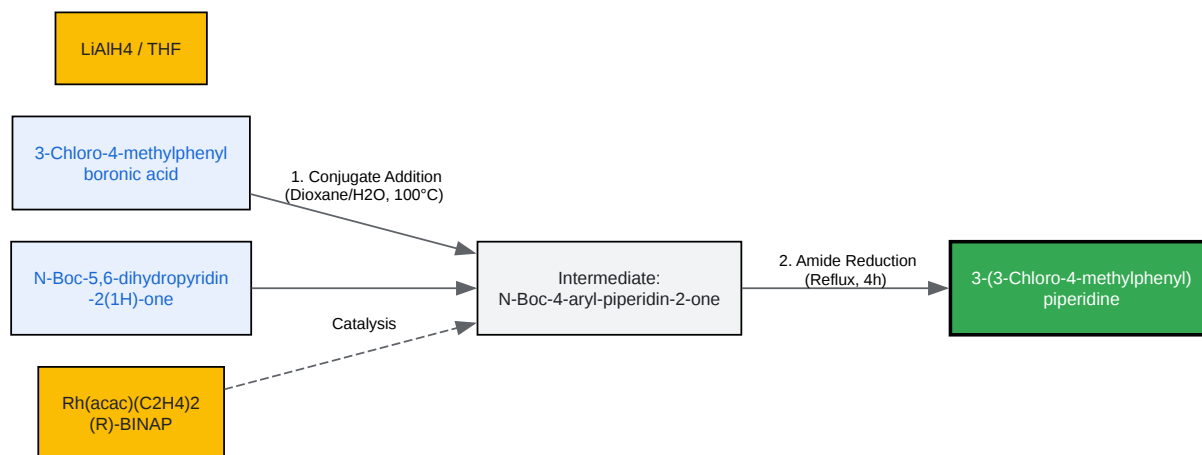

Figure 1: Stereoselective synthesis via Rh-catalyzed 1,4-addition followed by reduction.

[Click to download full resolution via product page](#)

Step-by-Step Methodology

Phase 1: Rhodium-Catalyzed Conjugate Addition

- Reagents: Combine 3-chloro-4-methylphenylboronic acid (1.2 equiv) and N-Boc-5,6-dihydropyridin-2(1H)-one (1.0 equiv) in a reaction vial.
- Catalyst System: Add $[\text{Rh}(\text{cod})\text{Cl}]_2$ (3 mol%) and (R)-BINAP (6 mol%) to induce enantioselectivity.
- Solvent: Dissolve in 1,4-dioxane/water (10:1 ratio).
- Reaction: Heat to 100°C under Argon atmosphere for 12 hours. Monitor via TLC (Hexane/EtOAc 3:1).^[1]
- Workup: Quench with saturated NH_4Cl . Extract with EtOAc.^[2] Purify intermediate via flash chromatography.

Phase 2: Amide Reduction

- Reduction: Dissolve the intermediate amide in anhydrous THF at 0°C.
- Addition: Slowly add LiAlH_4 (3.0 equiv) dropwise (exothermic).
- Reflux: Warm to room temperature, then reflux for 4 hours to ensure complete reduction of the carbonyl.
- Fieser Workup: Quench sequentially with water, 15% NaOH, and water. Filter the granular precipitate.
- Isolation: Convert the free base to the HCl salt using ethereal HCl for stability and crystallization.

Predicted Pharmacological Profile

Based on the SAR of the 3-phenylpiperidine scaffold (specifically comparing to 3,4-Dichlorophenylpiperidine and 3-PPP), the following profile is projected:

Binding Affinity & Selectivity

The addition of the 3-Cl and 4-Me groups creates a "super-lipophilic" core, likely increasing affinity for the DAT compared to the unsubstituted parent.

Receptor/Transporter	Predicted Affinity ()	Rationale
DAT (Dopamine Transporter)	High (< 50 nM)	3,4-disubstitution mimics the potent 3,4-dichlorophenyl pharmacophore.
NET (Norepinephrine Transporter)	Moderate (~100 nM)	3-arylpiperidines typically retain NET affinity; steric bulk at C4' may slightly reduce fit compared to DAT.
SERT (Serotonin Transporter)	Low (> 1000 nM)	3-substitution generally disfavors SERT binding compared to 4-substitution.
5-HT2A / D2 Receptors	Negligible	Lacks the specific pharmacophore distance required for direct receptor agonism unless N-substituted.

Mechanism of Action (Signaling Pathway)

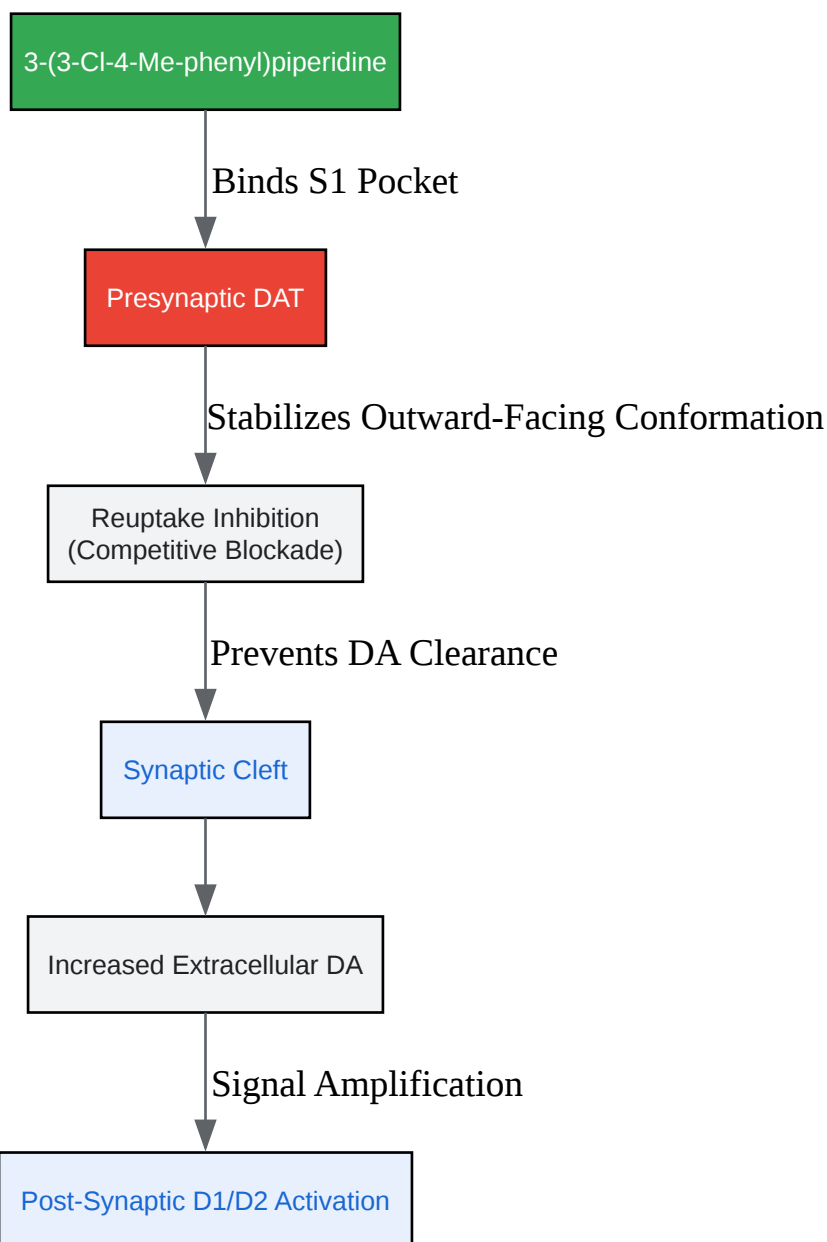

Figure 2: Mechanism of Action - Monoamine Reuptake Inhibition

[Click to download full resolution via product page](#)

[3][4][5]

References & Authoritative Sources

- Sonesson, C., et al. (1994). Substituted (S)-phenylpiperidines and rigid congeners as preferential dopamine autoreceptor antagonists: synthesis and structure-activity relationships. *Journal of Medicinal Chemistry*. [3][4] [Link](#)

- Mishra, S., et al. (2023).^{[5][6][7][8]} Catalytic Enantioselective Synthesis of 3-Piperidines from Arylboronic Acids and Pyridine.^[5] Journal of the American Chemical Society.^{[3][5]} [Link](#)^[5]
- Kozikowski, A. P., et al. (1998). Synthesis and biological properties of new 2beta-alkyl- and 2beta-aryl-3-(substituted phenyl)tropane derivatives. Journal of Medicinal Chemistry.^{[3][4]} (Context for 3,4-disubstitution effects). [Link](#)
- Trachsel, D. (2013). Phenethylamine: From Structure to Function.^[9] (Definitive text on phenethylamine/piperidine SAR).

Disclaimer: This guide is for research and educational purposes only. The compound described is a potent CNS active agent; all synthesis and handling must comply with local regulations and safety protocols.

Need Custom Synthesis?

BenchChem offers custom synthesis for rare earth carbides and specific isotopic labeling.

Email: info@benchchem.com or [Request Quote Online](#).

Sources

- 1. Bot Verification [rasayanjournal.co.in]
- 2. pdf.benchchem.com [pdf.benchchem.com]
- 3. pubs.acs.org [pubs.acs.org]
- 4. Document: Structure-activity relationships of trans-3,4-dimethyl-4-(3-hydroxyphenyl)piperidine antagonists for mu- and kappa-opioid receptors. (ChEMBL... - ChEMBL [ebi.ac.uk])
- 5. Catalytic Enantioselective Synthesis of 3-Piperidines from Arylboronic Acids and Pyridine [organic-chemistry.org]
- 6. pubs.acs.org [pubs.acs.org]
- 7. mdpi.com [mdpi.com]
- 8. researchgate.net [researchgate.net]
- 9. 3-Phenylpiperidine - Wikipedia [en.wikipedia.org]

- To cite this document: BenchChem. [Technical Guide: Structure-Activity Relationship of 3-(3-Chloro-4-methylphenyl)piperidine]. BenchChem, [2026]. [Online PDF]. Available at: [<https://www.benchchem.com/product/b13531470/docs#technical-guide-structure-activity-relationship-of-3-3-chloro-4-methylphenyl-piperidine>]

Disclaimer & Data Validity:

The information provided in this document is for Research Use Only (RUO) and is strictly not intended for diagnostic or therapeutic procedures. While BenchChem strives to provide accurate protocols, we make no warranties, express or implied, regarding the fitness of this product for every specific experimental setup.

Technical Support: The protocols provided are for reference purposes. Unsure if this reagent suits your experiment?

Need Industrial/Bulk Grade? [Request Custom Synthesis Quote](#)

BenchChem

Our mission is to be the trusted global source of essential and advanced chemicals, empowering scientists and researchers to drive progress in science and industry.

Contact

Address: 3281 E Guasti Rd
Ontario, CA 91761, United States
Phone: (601) 213-4426
Email: info@benchchem.com

[Contact our Ph.D. Support Team for a compatibility check](#)