

Stille vs. Suzuki Coupling: A Comparative Guide for Isothiazole Functionalization

Author: BenchChem Technical Support Team. **Date:** May 2026

Compound of Interest

Compound Name: 3-Methoxy-5-(tributylstannyl)isothiazole
Cat. No.: B13530110

[Get Quote](#)

The isothiazole ring is a privileged scaffold in medicinal chemistry, forming the core of numerous pharmaceuticals due to its unique electronic properties and ability to engage in various biological interactions. The effective functionalization of this heterocycle is paramount in drug discovery programs for building molecular complexity and fine-tuning structure-activity relationships (SAR). Among the arsenal of cross-coupling reactions, the Stille and Suzuki-Miyaura couplings have emerged as powerful and versatile tools for creating carbon-carbon bonds on the isothiazole nucleus.

This guide provides an in-depth comparison of these two seminal reactions for the specific application of isothiazole functionalization. We will delve into their mechanistic underpinnings, explore the practical aspects of reaction setup and substrate scope, and provide field-proven experimental protocols to empower researchers in selecting the optimal method for their synthetic challenges.

The Mechanistic Landscape: A Tale of Two Transmetalations

Both the Stille and Suzuki couplings are palladium-catalyzed reactions that follow a similar, fundamental catalytic cycle: oxidative addition, transmetalation, and reductive elimination.[1][2] The critical difference lies in the nature of the organometallic nucleophile and the requirements for the key transmetalation step.

The Stille Coupling: A Direct Transfer

Discovered by John Kenneth Stille, this reaction couples an organostannane (organotin) reagent with an organic halide or pseudohalide.[1][3] The organostannane reagents are notable for being stable to air and moisture, which simplifies handling.[1][4] The catalytic cycle proceeds without the need for an activating agent for the nucleophile.

The core mechanism involves:

- Oxidative Addition: The active Pd(0) catalyst inserts into the carbon-halogen bond of the isothiazole halide, forming a Pd(II) intermediate.[1][5]
- Transmetalation: The organic group from the organostannane is transferred to the palladium center, displacing the halide. This is often the rate-determining step.[6]
- Reductive Elimination: The two coupled organic fragments are expelled from the palladium center, forming the desired C-C bond and regenerating the Pd(0) catalyst.[1][3]

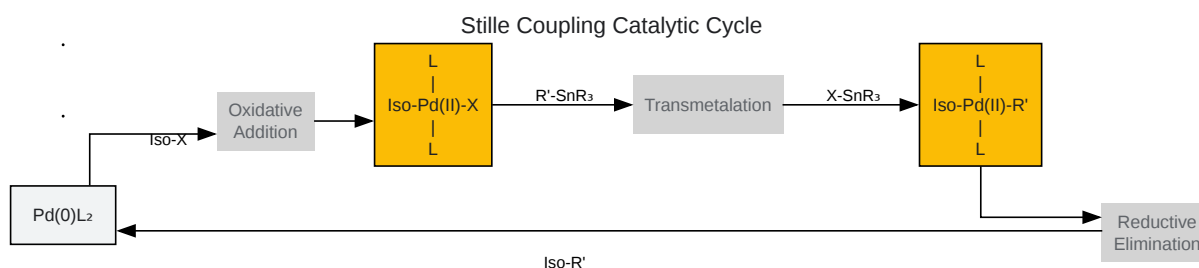

[Click to download full resolution via product page](#)

Stille Coupling Catalytic Cycle

The Suzuki-Miyaura Coupling: Base-Activated Transfer

First reported by Akira Suzuki and Norio Miyaura, this reaction utilizes an organoboron species, typically a boronic acid or a boronic ester, as the nucleophilic partner.[7] A key distinction from the Stille coupling is the requirement of a base to activate the organoboron reagent.[2][8]

The mechanism involves:

- **Oxidative Addition:** Identical to the Stille coupling, the Pd(0) catalyst adds to the isothiazole halide.
- **Activation & Transmetalation:** The base (e.g., K_2CO_3 , Cs_2CO_3 , K_3PO_4) reacts with the boronic acid to form a more nucleophilic boronate "ate" complex (e.g., $[R'-B(OH)_3]^-$).[8] This activated species then undergoes transmetalation with the Pd(II) intermediate. The exact mechanism of transmetalation is complex and still under investigation.[7]
- **Reductive Elimination:** The newly formed diorganopalladium(II) complex undergoes reductive elimination to yield the functionalized isothiazole and regenerate the Pd(0) catalyst.

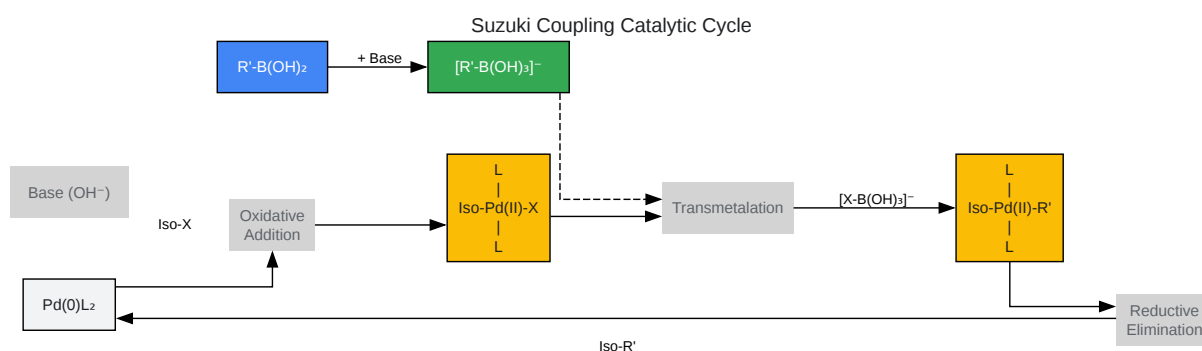

[Click to download full resolution via product page](#)

Suzuki Coupling Catalytic Cycle

Head-to-Head Comparison for Isothiazole Functionalization

The choice between Stille and Suzuki coupling is not arbitrary; it is a strategic decision based on substrate properties, desired scale, and downstream applications. The following table summarizes key considerations for the functionalization of isothiazoles.

Feature	Stille Coupling	Suzuki-Miyaura Coupling
Nucleophile	Organostannanes (R-SnBu ₃ , R-SnMe ₃)	Boronic Acids (R-B(OH) ₂) or Esters (e.g., Pinacol)
Toxicity & Green Chemistry	Major Drawback. Organotin reagents and byproducts are highly toxic and difficult to remove completely. [1] [9] [10] [11] This is a significant barrier for pharmaceutical applications.	Major Advantage. Boronic acids and their byproducts generally exhibit low toxicity and are considered environmentally benign. [2] [12]
Functional Group Tolerance	Excellent. Reaction conditions are typically neutral, tolerating a wide array of functional groups including esters, amides, and ketones. [13] [14]	Very Good. While requiring a base, a wide range of mild bases (carbonates, phosphates) are effective, allowing compatibility with many functional groups. [15] [16] Base-sensitive substrates may require careful optimization.
Reaction Setup & Reagents	Organostannanes are often air- and moisture-stable, simplifying handling. [1] [4] The reaction does not require a base.	Boronic acids are generally stable solids, but can be prone to protodeboronation, especially electron-deficient or some heteroaryl variants. [12] Requires careful selection of a base.
Byproduct Removal	Challenging. Tin byproducts (e.g., Bu ₃ SnCl) are often difficult to separate from the product. Aqueous KF workups or specialized chromatography are required. [4] [11]	Generally straightforward. Boron byproducts are typically water-soluble and easily removed by standard aqueous workup and chromatography.
Scope on Isothiazoles	Well-established for isothiazoles. Particularly	Widely used and highly versatile. However, catalyst

effective for coupling at the C5 position of 3-haloisothiazoles. [17] Can be more reliable for certain sterically hindered or electronically challenging substrates.[18]

deactivation by the isothiazole nitrogen can be a challenge. [19] Some positions (e.g., C3) can be less reactive and may fail to couple under standard conditions.[17]

Commercial Availability

Many organostannanes are commercially available or can be synthesized, but the selection can be more limited and expensive than boronic acids.[1]

A vast and diverse library of boronic acids and esters is commercially available at a lower cost, facilitating rapid SAR exploration.[7]

Experimental Protocols: From Theory to Practice

The following are generalized, yet robust, starting protocols for the functionalization of a haloisothiazole. Safety Note: All reactions should be performed in a well-ventilated fume hood by trained personnel, wearing appropriate personal protective equipment (PPE).

Workflow Overview: Stille vs. Suzuki

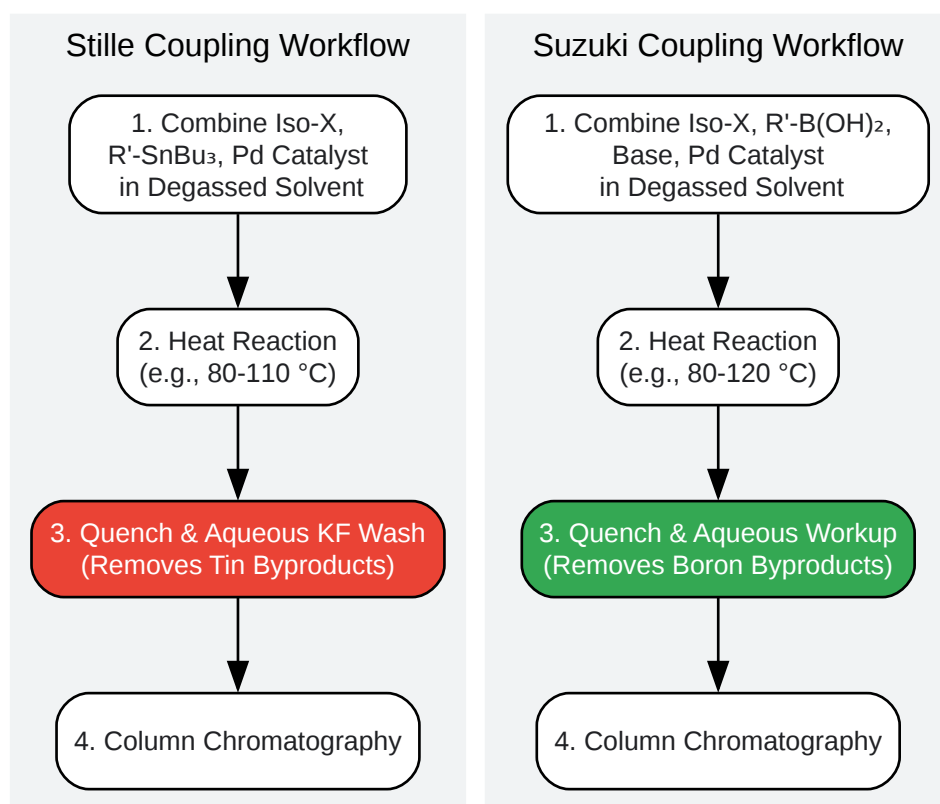

[Click to download full resolution via product page](#)

Need Custom Synthesis?

BenchChem offers custom synthesis for rare earth carbides and specific isotopic labeling.

Email: info@benchchem.com or [Request Quote Online](#).

Sources

- [1. Stille reaction - Wikipedia \[en.wikipedia.org\]](#)
- [2. chem.libretexts.org \[chem.libretexts.org\]](#)
- [3. Stille Coupling | OpenOChem Learn \[learn.openochem.org\]](#)
- [4. organic-synthesis.com \[organic-synthesis.com\]](#)
- [5. chem.libretexts.org \[chem.libretexts.org\]](#)
- [6. pubs.acs.org \[pubs.acs.org\]](#)

- 7. Suzuki reaction - Wikipedia [en.wikipedia.org]
- 8. Suzuki Coupling [organic-chemistry.org]
- 9. Stille Coupling [organic-chemistry.org]
- 10. Tetraalkynylstannanes in the Stille cross coupling reaction: a new effective approach to arylalkynes - New Journal of Chemistry (RSC Publishing) DOI:10.1039/C6NJ03905G [pubs.rsc.org]
- 11. sdlookchem.com [sdlookchem.com]
- 12. Elucidating the Role of the Boronic Esters in the Suzuki–Miyaura Reaction: Structural, Kinetic, and Computational Investigations - PMC [pmc.ncbi.nlm.nih.gov]
- 13. Organic Syntheses Procedure [orgsyn.org]
- 14. organicreactions.org [organicreactions.org]
- 15. chemrxiv.org [chemrxiv.org]
- 16. Suzuki-Miyaura Cross-Coupling of Unprotected, Nitrogen-Rich Heterocycles: Substrate Scope and Mechanistic Investigation - PMC [pmc.ncbi.nlm.nih.gov]
- 17. New regiospecific isothiazole C-C coupling chemistry - PubMed [pubmed.ncbi.nlm.nih.gov]
- 18. Stille vs. Suzuki – cross-coupling for the functionalization of diazocines - PMC [pmc.ncbi.nlm.nih.gov]
- 19. pdf.benchchem.com [pdf.benchchem.com]
- To cite this document: BenchChem. [Stille vs. Suzuki Coupling: A Comparative Guide for Isothiazole Functionalization]. BenchChem, [2026]. [Online PDF]. Available at: [https://www.benchchem.com/product/b13530110/docs#stille-vs-suzuki-coupling-a-comparative-guide-for-isothiazole-functionalization]

Disclaimer & Data Validity:

The information provided in this document is for Research Use Only (RUO) and is strictly not intended for diagnostic or therapeutic procedures. While BenchChem strives to provide accurate protocols, we make no warranties, express or implied, regarding the fitness of this product for every specific experimental setup.

Technical Support: The protocols provided are for reference purposes. Unsure if this reagent suits your experiment?

Need Industrial/Bulk Grade? [Request Custom Synthesis Quote](#)

BenchChem

Our mission is to be the trusted global source of essential and advanced chemicals, empowering scientists and researchers to drive progress in science and industry.

Contact

Address: 3281 E Guasti Rd
Ontario, CA 91761, United States
Phone: (601) 213-4426
Email: info@benchchem.com

[Contact our Ph.D. Support Team for a compatibility check](#)