

The Diverse Biological Landscape of 2,3-Dichloroquinoline Derivatives: A Technical Guide

Author: BenchChem Technical Support Team. **Date:** December 2025

Compound of Interest

Compound Name: 2,3-Dichloroquinoline

Cat. No.: B1353807

[Get Quote](#)

For Researchers, Scientists, and Drug Development Professionals

The quinoline scaffold is a cornerstone in medicinal chemistry, renowned for its presence in a wide array of biologically active compounds. Among its many halogenated derivatives, the **2,3-dichloroquinoline** core has emerged as a versatile building block for the synthesis of novel therapeutic agents. The presence of two reactive chlorine atoms at the C2 and C3 positions allows for diverse chemical modifications, leading to a broad spectrum of pharmacological activities. This technical guide provides an in-depth exploration of the biological activities of **2,3-dichloroquinoline** derivatives, with a focus on their anticancer and antimicrobial properties. It includes a summary of quantitative data, detailed experimental protocols, and visualizations of key signaling pathways to aid in the rational design of new and more effective therapeutic molecules.

Anticancer Activity of 2,3-Dichloroquinoline Derivatives

Derivatives of **2,3-dichloroquinoline** have demonstrated significant potential as anticancer agents, exhibiting cytotoxicity against a range of human cancer cell lines. The mechanism of action often involves the inhibition of key enzymes and signaling pathways crucial for cancer cell proliferation and survival.

Quantitative Anticancer Data

The following table summarizes the in vitro cytotoxic activity of various **2,3-dichloroquinoline** derivatives against several human cancer cell lines. The data is presented as IC50 values, representing the concentration of the compound required to inhibit the growth of 50% of the cancer cells.

Compound ID	Derivative Class	Cancer Cell Line	IC50 (μM)	Reference
1a	2-Chloro-3-(2-amino-3-cyano-4H-chromen-4-yl)quinoline	MCF-7 (Breast)	20.3 ± 2.1	[1][2]
1b	2-Chloro-3-(2-amino-3-cyano-4H-chromen-4-yl)quinoline	HCT-116 (Colon)	15.8 ± 1.3	[2]
1c	2-Chloro-3-(2-amino-3-cyano-4H-chromen-4-yl)quinoline	PC-3 (Prostate)	28.2 ± 3.4	[2]
1d	2-Chloro-3-(2-amino-3-cyano-4H-chromen-4-yl)quinoline	HepG2 (Liver)	25.1 ± 2.9	[2]
2a	2-Chloro-3-(2-amino-7-hydroxy-4H-chromen-3-carbonitrile)quinoline	MCF-7 (Breast)	Not Specified	[1]
2b	2-Chloro-3-(2-amino-7-hydroxy-4H-chromen-3-carbonitrile)quinoline	Topoisomerase I Inhibition	Not Specified	[1][2]
2c	2-Chloro-3-(2-amino-7-hydroxy-4H-chromen-3-	EGFR-TK Inhibition	Not Specified	[1][2]

carbonitrile)quino
line

Note: Direct comparison of IC50 values between different studies should be approached with caution due to potential variations in experimental conditions.

Key Signaling Pathways in Anticancer Activity

Several signaling pathways have been identified as targets for quinoline derivatives, contributing to their anticancer effects. While research specifically on **2,3-dichloroquinoline** derivatives is ongoing, the broader class of chloroquinolines is known to modulate pathways such as PI3K/Akt/mTOR and STAT3 signaling.

PI3K/Akt/mTOR Pathway Inhibition

The PI3K/Akt/mTOR pathway is a critical regulator of cell growth, proliferation, and survival, and its aberrant activation is a hallmark of many cancers. Certain quinoline derivatives have been shown to inhibit this pathway, leading to the suppression of tumor growth.

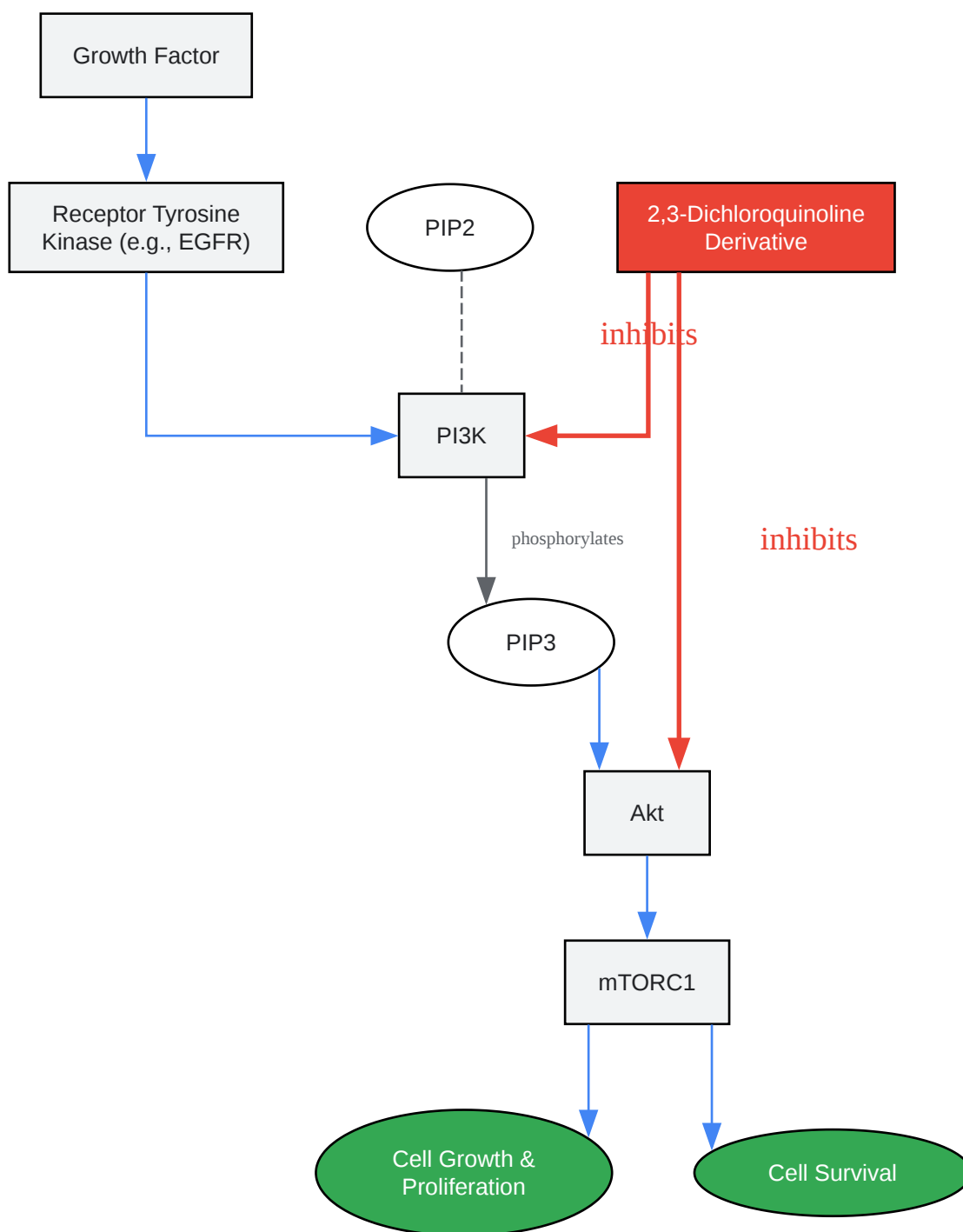

[Click to download full resolution via product page](#)

Inhibition of the PI3K/Akt/mTOR signaling pathway by **2,3-dichloroquinoline** derivatives.

STAT3 Signaling Pathway Inhibition

The Signal Transducer and Activator of Transcription 3 (STAT3) is a transcription factor that plays a pivotal role in tumor cell proliferation, survival, and invasion. Constitutive activation of STAT3 is common in many cancers, making it an attractive therapeutic target. Quinoline-based compounds have been investigated as STAT3 inhibitors.

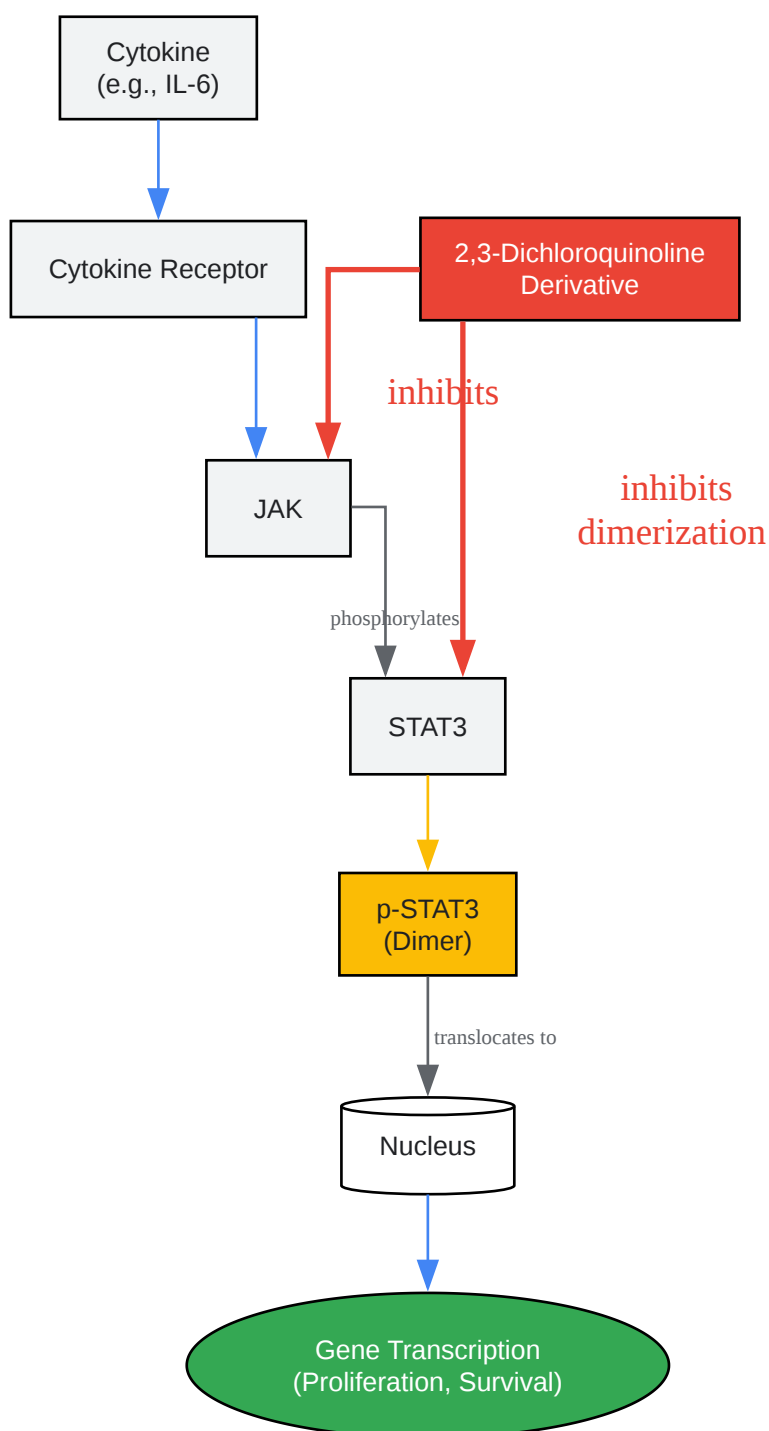

[Click to download full resolution via product page](#)

Inhibition of the STAT3 signaling pathway by **2,3-dichloroquinoline** derivatives.

Antimicrobial Activity of 2,3-Dichloroquinoline Derivatives

In addition to their anticancer properties, **2,3-dichloroquinoline** derivatives have shown promise as antimicrobial agents, exhibiting activity against a variety of bacterial and fungal strains.

Quantitative Antimicrobial Data

The following table presents the Minimum Inhibitory Concentration (MIC) values of selected chloroquinoline derivatives against various microbial strains. The MIC is the lowest concentration of an antimicrobial agent that prevents the visible growth of a microorganism.

Compound ID	Derivative	Bacterial Strain	MIC ($\mu\text{g/mL}$)	Reference
3a	2,7-Dichloroquinoline-3-carbonitrile	Staphylococcus aureus	11.00 \pm 0.03 (zone of inhibition in mm)	[3]
3b	2,7-Dichloroquinoline-3-carbonitrile	Pseudomonas aeruginosa	11.00 \pm 0.03 (zone of inhibition in mm)	[3]
4a	2,7-Dichloroquinoline-3-carboxamide	Escherichia coli	11.00 \pm 0.04 (zone of inhibition in mm)	[3]
5a	7-Chloro-2-ethoxyquinoline-3-carbaldehyde	Escherichia coli	12.00 \pm 0.00 (zone of inhibition in mm)	[3]
6a	7-Chloro-2-methoxyquinoline-3-carbaldehyde	Streptococcus pyogenes	11.00 \pm 0.02 (zone of inhibition in mm)	[3]

Note: The data for compounds 3a, 3b, 4a, 5a, and 6a are presented as zones of inhibition, which is a qualitative measure of antimicrobial activity.

Experimental Protocols

The following are detailed methodologies for the key experiments cited in this guide.

In Vitro Cytotoxicity Assessment (MTT Assay)

This protocol is used to determine the concentration-dependent cytotoxic effect of a test compound on cancer cell lines.

1. Cell Seeding:

- Cancer cells are seeded into 96-well plates at a density of 5,000-10,000 cells per well in 100 μ L of complete culture medium.
- The plates are incubated for 24 hours at 37°C in a 5% CO₂ humidified atmosphere to allow for cell attachment.

2. Compound Treatment:

- Serial dilutions of the **2,3-dichloroquinoline** derivatives are prepared in complete medium.
- The medium from the cell plates is removed, and 100 μ L of the medium containing various concentrations of the test compounds is added to the respective wells.
- Control wells include a vehicle control (medium with the same concentration of solvent, e.g., DMSO, as the test compounds) and an untreated control (cells in medium only).
- The plates are incubated for 48 to 72 hours.

3. MTT Addition and Incubation:

- After the treatment period, 20 μ L of a 5 mg/mL solution of MTT (3-(4,5-dimethylthiazol-2-yl)-2,5-diphenyltetrazolium bromide) in phosphate-buffered saline (PBS) is added to each well.

- The plates are incubated for an additional 4 hours at 37°C, during which viable cells metabolize the yellow MTT into purple formazan crystals.

4. Formazan Solubilization and Absorbance Measurement:

- The medium containing MTT is removed, and 100 µL of a solubilization solution (e.g., DMSO) is added to each well to dissolve the formazan crystals.
- The absorbance is measured at a wavelength of 570 nm using a microplate reader.

5. Data Analysis:

- The percentage of cell viability is calculated for each concentration relative to the untreated control.
- The IC50 value is determined by plotting the percentage of cell viability against the compound concentration and fitting the data to a dose-response curve.



[Click to download full resolution via product page](#)

Workflow for the MTT cytotoxicity assay.

Antimicrobial Susceptibility Testing (Broth Microdilution)

This protocol is used to determine the Minimum Inhibitory Concentration (MIC) of a compound against various microbial strains.

1. Preparation of Materials:

- Test Compound: Prepare a stock solution of the **2,3-dichloroquinoline** derivative in a suitable solvent (e.g., DMSO).

- Media: Use appropriate broth medium (e.g., Mueller-Hinton Broth for bacteria, RPMI-1640 for fungi).

- Microorganism: Use a fresh culture of the test microorganism.

2. Inoculum Preparation:

- Prepare a suspension of the microorganism and adjust its turbidity to a 0.5 McFarland standard.
- Dilute this suspension in the broth medium to achieve a final inoculum concentration of approximately 5×10^5 colony-forming units (CFU)/mL.

3. Microtiter Plate Preparation:

- Perform a two-fold serial dilution of the test compound in the wells of a 96-well microtiter plate using the broth medium.
- Include a growth control well (no compound) and a sterility control well (no microorganism).

4. Inoculation and Incubation:

- Add the standardized inoculum to each well (except the sterility control).
- Incubate the plates at an appropriate temperature (e.g., 35-37°C) for 16-24 hours for bacteria or 24-72 hours for fungi.

5. MIC Determination:

- After incubation, visually inspect the plates for turbidity (growth).
- The MIC is the lowest concentration of the compound at which there is no visible growth.

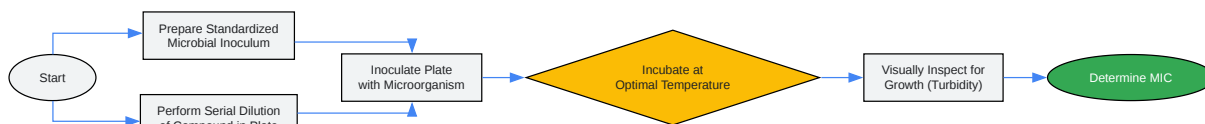

[Click to download full resolution via product page](#)

Workflow for the broth microdilution antimicrobial susceptibility test.

Conclusion

The **2,3-dichloroquinoline** scaffold represents a promising starting point for the development of novel anticancer and antimicrobial agents. The available data, though still emerging, highlights the potential of these derivatives to inhibit cancer cell growth and combat microbial infections. Further research, focusing on the synthesis of diverse libraries of **2,3-dichloroquinoline** derivatives and comprehensive biological evaluation, is warranted to fully elucidate their therapeutic potential. The detailed experimental protocols and an understanding of the targeted signaling pathways provided in this guide serve as a valuable resource for researchers dedicated to advancing the field of quinoline-based drug discovery.

Need Custom Synthesis?

BenchChem offers custom synthesis for rare earth carbides and specific isotopic labeling.

Email: info@benchchem.com or [Request Quote Online](#).

References

- 1. researchgate.net [researchgate.net]
- 2. researchgate.net [researchgate.net]
- 3. researchgate.net [researchgate.net]
- To cite this document: BenchChem. [The Diverse Biological Landscape of 2,3-Dichloroquinoline Derivatives: A Technical Guide]. BenchChem, [2025]. [Online PDF]. Available at: [<https://www.benchchem.com/product/b1353807#biological-activity-of-2-3-dichloroquinoline-derivatives>]

Disclaimer & Data Validity:

The information provided in this document is for Research Use Only (RUO) and is strictly not intended for diagnostic or therapeutic procedures. While BenchChem strives to provide accurate protocols, we make no warranties, express or implied, regarding the fitness of this product for every specific experimental setup.

Technical Support: The protocols provided are for reference purposes. Unsure if this reagent suits your experiment? [[Contact our Ph.D. Support Team for a compatibility check](#)]

Need Industrial/Bulk Grade? [Request Custom Synthesis Quote](#)

BenchChem

Our mission is to be the trusted global source of essential and advanced chemicals, empowering scientists and researchers to drive progress in science and industry.

Contact

Address: 3281 E Guasti Rd

Ontario, CA 91761, United States

Phone: (601) 213-4426

Email: info@benchchem.com