

# Application Note: Precision Synthesis of Kinase Inhibitors Using 6-Trifluoromethylisatin

**Author:** BenchChem Technical Support Team. **Date:** May 2026

## Compound of Interest

Compound Name: 6-Trifluoromethylisatin

CAS No.: 343-69-1

Cat. No.: B1353571

[Get Quote](#)

## Executive Summary & Chemical Rationale

The isatin (1H-indole-2,3-dione) scaffold is a privileged structure in kinase inhibitor design, serving as a hydrogen-bond donor/acceptor mimic for the ATP adenine ring within the kinase hinge region.

The incorporation of a trifluoromethyl (-CF<sub>3</sub>) group at the C6 position is not merely a substituent change; it is a strategic electronic and metabolic modification.

- **Metabolic Stability:** The C6 position of the oxindole core is a metabolic "soft spot," prone to cytochrome P450-mediated oxidation (hydroxylation). Blocking this site with a metabolically inert -CF<sub>3</sub> group significantly extends half-life ( ).
- **Electronic Modulation:** The strong electron-withdrawing nature of -CF<sub>3</sub> increases the acidity of the N1-H (pyrrole-like NH), strengthening the hydrogen bond interaction with the kinase hinge region (e.g., Glu residue in VEGFR2).

- Lipophilicity: The -CF<sub>3</sub> group enhances membrane permeability (logP) and hydrophobic interactions within the solvent-exposed or back-pocket regions of the ATP binding site.

This guide focuses on two high-value synthetic pathways:

- The "Sunitinib-Like" Route: Reduction to oxindole followed by aldol condensation (Targeting VEGFR, PDGFR).
- The Direct Condensation Route: Synthesis of hydrazone/Schiff base inhibitors (Targeting CDK, GSK-3

).

## Strategic Reaction Workflow (Visualization)

The following diagram outlines the divergent synthetic pathways starting from **6-Trifluoromethylisatin**.

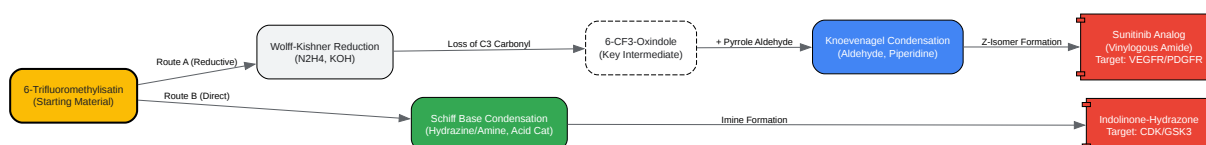

[Click to download full resolution via product page](#)

Figure 1: Divergent synthetic pathways for **6-Trifluoromethylisatin**. Route A targets multi-targeted tyrosine kinase inhibitors (like Sunitinib), while Route B targets serine/threonine kinases.

## Detailed Experimental Protocols

### Protocol A: Synthesis of 6-CF<sub>3</sub>-Sunitinib Analogs

This protocol synthesizes a bioisostere of Sunitinib (Sutent), replacing the 5-fluoro group with 6-trifluoromethyl to probe the hydrophobic back-pocket of the VEGFR ATP site.

## Phase 1: Reduction to 6-Trifluoromethyl-2-oxindole

Isatin must be reduced to oxindole (indolin-2-one) to activate the C3 position for condensation.

Reagents:

- **6-Trifluoromethylisatin** (10 mmol)
- Hydrazine hydrate (80%, 10 mL)
- Potassium Hydroxide (KOH) pellets
- Ethylene Glycol (Solvent)

Step-by-Step:

- Setup: In a 50 mL round-bottom flask, dissolve **6-Trifluoromethylisatin** (2.15 g, 10 mmol) in Ethylene Glycol (15 mL).
- Hydrazone Formation: Add Hydrazine hydrate (2 mL) dropwise. Heat to 100°C for 1 hour.
  - Self-Validating Check: The deep orange/red solution should turn yellow as the hydrazone forms.
- Wolf-Kishner Reduction: Cool the mixture to 60°C. Add KOH pellets (1.5 g) carefully.
- High-Heat Reflux: Heat the reaction to 160–180°C for 3–4 hours.
  - Mechanistic Insight: High temperature is required to drive N<sub>2</sub> evolution.
- Workup: Cool to room temperature (RT). Pour into ice-water (100 mL). Acidify with HCl (6N) to pH 2–3.
- Isolation: Extract with Ethyl Acetate (3 x 50 mL). Wash with brine, dry over Na<sub>2</sub>SO<sub>4</sub>, and concentrate.

- Expected Result: Off-white to pale yellow solid. Yield: ~70–80%.

## Phase 2: Knoevenagel Condensation

Coupling the oxindole with a pyrrole aldehyde to form the active inhibitor.

Reagents:

- 6-Trifluoromethyl-2-oxindole (from Phase 1)
- 5-Formyl-2,4-dimethyl-1H-pyrrole-3-carboxylic acid (or ester derivative)
- Piperidine (Catalyst)
- Ethanol (Absolute)

Step-by-Step:

- Mixing: Suspend 6-CF<sub>3</sub>-oxindole (1.0 eq) and the pyrrole aldehyde (1.1 eq) in Ethanol (10 mL/g).
- Catalysis: Add Piperidine (0.1 eq).
- Reflux: Heat to reflux (78°C) for 3–6 hours.
  - Self-Validating Check: The reaction is driven by product precipitation. The pale yellow solution will darken, and a bright yellow/orange precipitate will form (the vinylogous amide).
- Completion: Monitor by TLC (Mobile Phase: 5% MeOH in DCM). Disappearance of the oxindole spot indicates completion.
- Purification: Cool to RT, then chill on ice. Filter the precipitate. Wash with cold Ethanol (2x) and Hexane (1x) to remove unreacted aldehyde.
  - Purity Check: This method typically yields >95% purity due to the low solubility of the Z-isomer product in ethanol.

## Protocol B: Direct Synthesis of Indolinone Hydrazones

Used for generating diverse libraries targeting CDK or GSK-3.

Reagents:

- **6-Trifluoromethylisatin**
- Hydrazine derivative (e.g., Phenylhydrazine or Isonicotinic acid hydrazide)
- Glacial Acetic Acid (Catalyst)
- Methanol

Step-by-Step:

- Dissolution: Dissolve **6-Trifluoromethylisatin** (1.0 eq) in Methanol (warm if necessary).
- Addition: Add the hydrazine derivative (1.1 eq) and 2–3 drops of Glacial Acetic Acid.
- Reaction: Reflux for 2–4 hours.
  - Visual Cue: A distinct color shift (usually to deep red or brown) indicates Schiff base formation.
- Isolation: Cool to RT. The product often crystallizes out. If not, reduce volume by 50% and chill. Filter and wash with cold methanol.

## Data Analysis & Validation Standards

To ensure the synthesized inhibitor meets "Drug-Like" standards, the following characterization data must be obtained.

### NMR Interpretation (1H & 19F)

- NH Proton (Isatin Core): Look for a singlet downfield at 10.5–11.5 ppm. The electron-withdrawing CF<sub>3</sub> group will shift this downfield compared to unsubstituted isatin.

- Vinyl Proton (Sunitinib Analogs): A singlet at 7.6–7.8 ppm confirms the presence of the exocyclic double bond (Z-isomer).
- <sup>19</sup>F NMR: A single peak around -60 to -63 ppm confirms the integrity of the trifluoromethyl group. If multiple peaks appear, check for ring degradation or impurities.

## Quantitative Yield & Purity Table

Parameter	Target Specification	Troubleshooting
Appearance	Bright Yellow/Orange Solid	Dark brown/black indicates oxidation (run under N <sub>2</sub> ).
HPLC Purity	> 98% (AUC)	Recrystallize from EtOH/DMF if <95%.
Yield (Step 1)	> 75%	Incomplete reduction? Increase temp to 180°C.
Yield (Step 2)	> 85%	No precipitate? Concentrate solvent or add water.
Mass Spec (ESI)	[M+H] <sup>+</sup> or [M-H] <sup>-</sup>	6-CF <sub>3</sub> adds +68 Da relative to H-analog.

## Mechanism of Action & SAR Logic

The efficacy of 6-CF<sub>3</sub>-isatin derivatives relies on specific binding modes within the kinase pocket.

Structure-Activity Relationship (SAR):

- Hinge Binding: The lactam (NH-CO) of the isatin core forms a bidentate H-bond with the kinase hinge residues (e.g., Glu917/Cys919 in VEGFR2).
- Gatekeeper Interaction: The C6-CF<sub>3</sub> group is positioned to interact with the hydrophobic gatekeeper region or the solvent front, depending on the specific kinase conformation (DFG-in vs. DFG-out).

- Halogen Bonding: The fluorine atoms can engage in orthogonal dipolar interactions with backbone carbonyls, enhancing residence time.

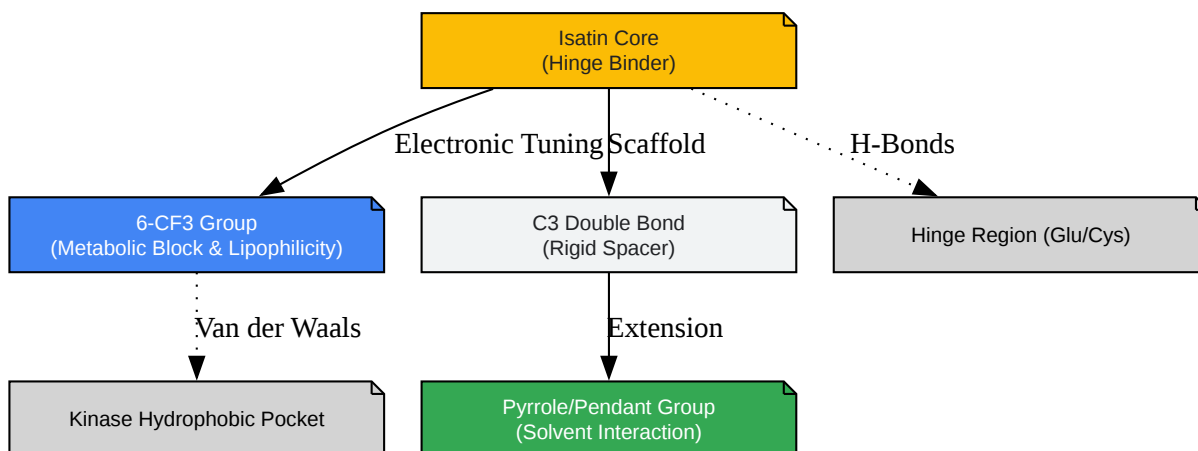

[Click to download full resolution via product page](#)

Figure 2: Pharmacophore mapping of 6-CF3-isatin kinase inhibitors.

## References

- Title: Process for the preparation of high purity sunitinib and its pharmaceutically acceptable salt.
- Fluorine in Drug Design
  - Title: Tactical Applications of Fluorine in Drug Design and Development.[1]
  - Source: ResearchGate (Chapter).[1]
  - URL:[[Link](#)]
- Isatin Biological Activity
  - Title: Biological activities of isatin and its derivatives.[2][3][4][5]
  - Source: PubMed (Review).

- URL:[[Link](#)]
- Synthetic Methodology (Oxindoles)
  - Title: Synthetic pathways to 5-fluoroindolin-2-one: Key intermediate for Sunitinib.[6]
  - Source: Chemistry of Heterocyclic Compounds.[2]
  - URL:[[Link](#)]
- Fluorinated Isatins & Apoptosis
  - Title: Fluorinated isatin derivatives. Part 3. New side-chain fluoro-functionalized pyrrolidinyl sulfonyl isatins as potent caspase-3 and -7 inhibitors.[5]
  - Source: PubMed.
  - URL:[[Link](#)]

#### *Need Custom Synthesis?*

*BenchChem offers custom synthesis for rare earth carbides and specific isotopic labeling.*

*Email: [info@benchchem.com](mailto:info@benchchem.com) or [Request Quote Online](#).*

## Sources

- [1. researchgate.net \[researchgate.net\]](#)
- [2. researchgate.net \[researchgate.net\]](#)
- [3. Biological activities of isatin and its derivatives - PubMed \[pubmed.ncbi.nlm.nih.gov\]](#)
- [4. Anticancer and Antiphytopathogenic Activity of Fluorinated Isatins and Their Water-Soluble Hydrazone Derivatives - PMC \[pmc.ncbi.nlm.nih.gov\]](#)
- [5. Fluorinated isatin derivatives. Part 3. New side-chain fluoro-functionalized pyrrolidinyl sulfonyl isatins as potent caspase-3 and -7 inhibitors - PubMed \[pubmed.ncbi.nlm.nih.gov\]](#)
- [6. SYNTHETIC PATHWAYS TO 5-FLUOROINDOLIN-2-ONE: KEY INTERMEDIATE FOR SUNITINIB | Chemistry of Heterocyclic Compounds \[hgs.osi.lv\]](#)

- To cite this document: BenchChem. [Application Note: Precision Synthesis of Kinase Inhibitors Using 6-Trifluoromethylisatin]. BenchChem, [2026]. [Online PDF]. Available at: [<https://www.benchchem.com/product/b1353571/docs#application-note-precision-synthesis-of-kinase-inhibitors-using-6-trifluoromethylisatin>]

---

### Disclaimer & Data Validity:

The information provided in this document is for Research Use Only (RUO) and is strictly not intended for diagnostic or therapeutic procedures. While BenchChem strives to provide accurate protocols, we make no warranties, express or implied, regarding the fitness of this product for every specific experimental setup.

**Technical Support:** The protocols provided are for reference purposes. Unsure if this reagent suits your experiment?

**Need Industrial/Bulk Grade?** [Request Custom Synthesis Quote](#)

## BenchChem

Our mission is to be the trusted global source of essential and advanced chemicals, empowering scientists and researchers to drive progress in science and industry.

### Contact

Address: 3281 E Guasti Rd  
Ontario, CA 91761, United States  
Phone: (601) 213-4426  
Email: [info@benchchem.com](mailto:info@benchchem.com)

[Contact our Ph.D. Support Team for a compatibility check](#)